

# NZCF 142

## AVIATION STUDIES MANUAL



**THIS AVIATION STUDIES MANUAL IS NOT TO BE ALTERED IN ANY WAY WITHOUT THE PRIOR CONSULTATION AND APPROVAL FROM THE COMMANDANT NEW ZEALAND CADET FORCES.**

*(Original Signed)*

**G. STOKES  
COMMANDER, RNZN  
COMMANDANT**

**May 2015**



## Introduction

This is a *living* document. There will be regular amendments to ensure that the training is both safe and as up-to-date as possible. It is the responsibility of all users to note and advise any errors or inconsistencies that may be detected, or any changes that maybe required to the provisions of the manual because of changes in procedures. Generally, any recommendation for change should be advised to the respective Area Co-ordinator who will pass it on to the Staff Officer Training and Development, HQ NZCF.

## CHAPTER 1 – Basic Aviation

### SECTION 1 - Basic Flight Aviation Studies Objectives

#### Basic Flight 2.1

- a. Aviation History.
- b. Time:
  - (1) One 40 min theory lesson.
- c. Objective(s):
  - (1) Describe briefly, the history of aviation.
- d. Scope / Range:
  - (1) Early flight;
  - (2) Historical points in aviation history; and
  - (3) Civil and commercial aviation.
- e. Reference(s):
  - (1) NZCF 142, Chapter One, Section One
  - (2) Video Clips.

#### Basic Flight 2.2

- a. Aircraft Construction.
- b. Time:
  - (1) One 40 min theory lesson
- c. Objective(s):
  - (1) State the methods of aircraft construction; and
  - (2) Identify the basic parts of an aircraft using the correct terminology.
- d. Scope / Range:
  - (1) Aircraft construction methods
  - (2) Basic parts of an aircraft
    - (a) Fuselage
    - (b) Wing

- (c) Empennage
  - (d) Undercarriage
  - (e) Cockpit
  - (f) Engine
  - (g) Primary flight controls
- e. Reference(s):
- (1) NZCF 142

### **Basic Flight 2.3**

- a. Principle of flight
- b. Time:
  - (1) One 40 min theory lesson
- c. Objective(s):
  - (1) Describe the basic principles of flight.
- d. Scope / Range:
  - (1) Bernoulli's principle.
  - (2) Production of lift
  - (3) Aerofoil terminology
  - (4) Four forces
- e. Reference(s):
  - (1) NZCF 142, Instructional Video

### **Basic Flight 2.4**

- a. Flight controls
- b. Time:
  - (1) One 40 min theory lesson
- c. Objective(s):
  - (1) State the three axis of movement
  - (2) State the purpose of primary and secondary flight controls

- d. Scope / Range:
  - (1) Three axis of movement
  - (2) Types of control
  - (3) Primary flight controls
  - (4) Secondary flight controls
- e. Reference(s):
  - (1) NZCF 142, Instructional Video

### **Basic Flight 2.5**

- a. Effect of controls
- b. Time:
  - (1) One 40 min theory lesson
- c. Objective(s):
  - (1) Explain the effect of controls on an aircraft in flight
- d. Scope / Range:
  - (1) Flight control requirements
  - (2) Effect of controls
- e. Reference(s):
  - (1) NZCF 142, Instructional Video

### **Basic Flight 2.6**

- a. Aircraft recognition
- b. Time:
  - (1) One 40 min theory lesson
- c. Objective(s):
  - (1) Identify Common Aircraft and their Roles
- d. Scope / Range:
  - (1) WEFTUS method.
  - (2) RNZAF Aircraft

(3) Common aircraft around NZ

e. Reference(s):

(1) NZCF 142 and photos of common aircraft in NZ

### **Basic Flight 2.7**

a. Aviation Studies Test

b. Time:

(1) One 40 min written test

c. Test:

(1) Maximum of 30 questions

d. Content:

(1) Test questions are to be raised from objectives covered in lessons BF 2.1 – BF 2.6.

(2) Questions are to be a mix of short answer, multiple choice, fill in the gaps and true/false.

e. Pass Mark:

(1) Minimum pass mark is 60% correctly answered

## SECTION 2 - History of Flight

### Early Flight

0.1 For many years man dreamed of flying through the air like the birds. It was not too surprising then that early attempts at flight tried to emulate bird flight by using flapping wings. Leonardo Da Vinci (1452 – 1519) the Italian artist and inventor produced many designs for flying machines which relied on this method. Fortunately he never built or tested any of his designs as they would never have worked – mans muscles are far too small to operate the massive wings that would be required to keep him airborne.

### Lighter Than Air Craft

0.2 It was not until the Montgolfier brothers built a hot air balloon in **1783** the man was able to realise his dream of getting airborne. The first balloon flight occurred on the 25th April 1783 at Annonay in France when a 39ft diameter un-manned balloon climbed to a height of 1000ft. As the hot air in the balloon cooled the balloon began to descend.

0.3 In September 1783 a sheep, a duck and a rooster became the first living things to become artificially airborne. They were followed later in the same year by the Maquis d'Arlandes and Francois Pilatre de Rozier who were the first humans to become artificially airborne when they made a free flight of 25 mins duration and travelled a distance of 9 km.

0.4 This marked the beginning of manned flight and the end of the Montgolfier Balloon as it was almost immediately superseded by a much superior and practical Hydrogen filled balloon developed by J. Charles. On the 1<sup>st</sup> Dec 1783 Charles and his assistant made a free flight of 43km and this was witnessed by over 400 000 people. The Charles balloon was so well designed that gas filled balloons used today are essentially similar to it. The main difference being that modern balloons use the inert gas helium rather than the highly flammable Hydrogen.

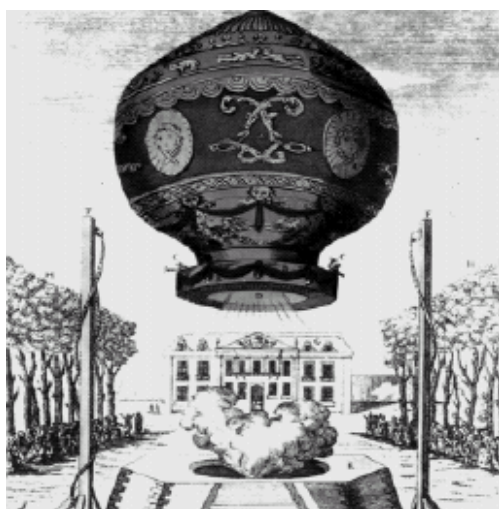

The Montgolfier Balloon

### How Does a Balloon Fly?

0.5 An inflated balloon displaces its own volume of air and so experiences a lifting force or up thrust. This up thrust is equal to the weight of air displaced. A helium balloon



inflated to the size of a house would contain about 1/2 tonne of gas and would displace about 4 tonnes of air.

0.6 The difference between these two weights would be the lifting force on the helium filled balloon. If this lifting force is greater than the total weight of the balloon, including the gas, envelope and gondola or basket, then the balloon will float.

0.7 As the balloon ascends, the atmospheric pressure falls and the balloon expands. To prevent the balloon from bursting, its gas must either be released gradually or allowed to expand into spare envelope space.



A balloon must displace its own weight of air in order to float

### Hot Air Ballooning

0.8 Hot-air ballooning is now a very popular sport and many companies fly specially designed balloons to advertise their names. Heating up air causes it to expand and become less dense. When this lighter air fills the balloon envelope it provides lift by displacing the heavier air outside, in much the same way as hydrogen and helium gas but at a fraction of the cost. The air is heated using large propane gas burners attached below the open neck of the balloon and, while in flight, ignited in short bursts to replace the cooling air. In this way the balloon is able to maintain altitude.



Hot Air Balloons

### How Make a Balloon Navigable

0.9 It was not long after the de Rozier's first flight in the Montgolfier balloon that the potential of such a vehicle used for military reconnaissance was seen. But there had to be some way of steering it - a basic balloon is simply carried along by the wind.

0.10 Early ideas of sails, oars and propellers proved useless. It had to be understood that if a lighter-than-air machine was to be steered, then there had to be a controllable force capable of propelling it independently of the wind. From this realisation and over 100 years after Montgolfier's first flight, the first airship designs were produced.

0.11 Engines were attached to provide independent forward motion and using rudders to act on the airflow caused by this forward motion provided control.

### Airships

0.12 Airships are not very common nowadays but in the early 1900s they were considered by many people to be the way forward for air travel. They were quiet and provided passengers with a high degree of comfort. Their ability to remain stationary relative to the ground while using very little fuel made them ideal for scientific and military work. Their size and lifting capacity enabled them to carry large cargoes relatively cheaply. Unfortunately, they were filled with hydrogen gas which made them extremely dangerous - hydrogen gas can be ignited with a tiny spark and will explode with tremendous force.

0.13 Because of this, there were many airship accidents and finally, when the passenger airship Hindenburg burst into flames at its moorings in 1937, many people lost confidence in them and the airship era was effectively over. Although helium gas was just becoming available as a completely safe alternative to hydrogen, it had unfortunately arrived too late.



The passenger airship Hindenburg burst into flames at its mooring post - 1937.

### How are Airships Controlled

0.14 Modern airships are benefiting from a revival. They are made with strong lightweight materials and have powerful engines which make them highly manoeuvrable.

0.15 Inside the main balloon are two ballonets - inflatable air bags that keep the pressure of the helium gas slightly higher than atmospheric pressure. This prevents the balloon from over inflating as the airship rises, or sagging as it descends. Also, pumping air from one ballonet to the other trims the airship balance.

### Airship Rising

0.16 To get the airship to rise, valves release air from the ballonets into the atmosphere, reducing the weight of the airship and allowing the helium gas to expand - giving more lift.

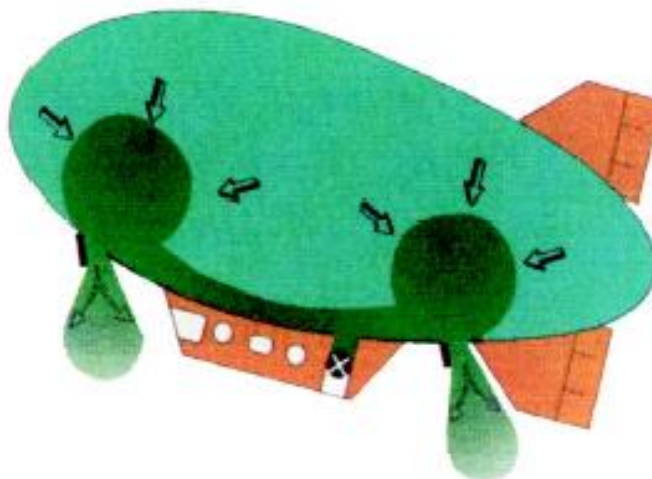

Valves release air from the ballonets and the airship rises.

### Airship Descending

0.17 To make the airship descend, pumps force air into the ballonets, increasing the airship's weight and compressing the helium gas so that lift is reduced.

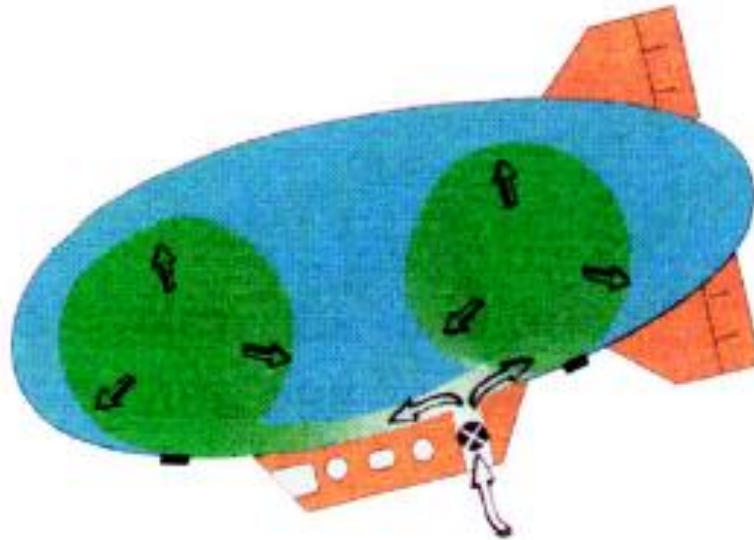

Pumps force air into the ballonets and the airship descends.

### Heavier Than Air Craft

0.18 It is believed that the first man-made flying object climbed skyward at least 3000 years ago on the end of a piece of string. The early Chinese people flew kites most probably as signalling devices or military banners heralding the approach of their armies. The technology of kite flying quickly spread throughout the world, with some kites almost certainly built large enough to lift a man used as a military observer.

### How Does a Kite Fly?

0.19 The most important features of this typical kite are its shape, its tail and the way in which the string is attached. Together, they make sure that the kite flies at the correct angle to the wind. The weight of the kite is balanced by the force of the wind underneath it, and also by a less obvious force called lift, caused by the kite's shape. Lift is produced by the wind passing over the top of the kite creating an area of low pressure, and by the air underneath the kite, at a slightly higher pressure, lifting the kite upwards.

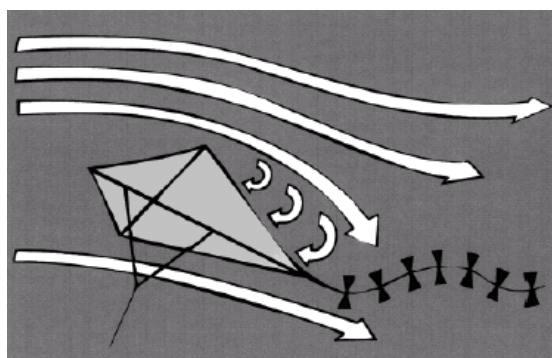

The air supports the weight of the kite.

### Free Flight

0.20 The next most obvious step forward in achieving flight in a heavier-than-air machine was to develop a kite which could fly without a line to the ground. In 1804 the

English Baronet Sir George Cayley built what is generally considered to be the first model glider. It was little more than a broomstick, to which was mounted a kite shaped wing at one end and vertical and horizontal tail surfaces at the other; nevertheless it was capable of stable flight over many metres.

0.21 With this device Cayley was able to confirm that the principles of heavier than- air flight were definitely possible. From this first model he evolved a glider that was capable of carrying a small boy, although there was no way of controlling this craft in flight.

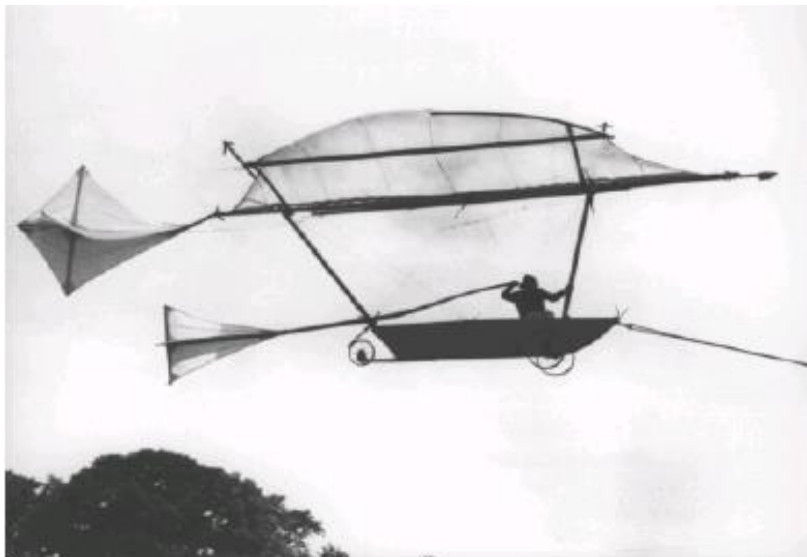

Reproduction of the Cayley glider

### Lack of Power

0.22 Also, around this time there were many men beginning to improve the construction of fixed-wing aircraft that could fly. Their main problem, however, was to find a reliable and light enough engine to provide the power they required. In June 1848, John Stringfellow from Chard in Somerset successfully flew his 10-foot wingspan model, powered by a tiny steam engine, across a long room in a disused lace mill. Attempts to make larger versions of steam-powered craft were unfortunately unsuccessful. The problems of suitable engines dogged aviation pioneers for many years.

0.23 The more practical aviators however, accepted this lack of sufficient engine power and concentrated on improving airframe design. They experimented with lightweight construction and tried to discover practical methods of controlling the aircraft in flight. Nobody was more successful in this than the German Otto Lilienthal (1848-1896) who built extremely lightweight gliders enabling him to make many thousands of flights. His gliders were the forerunners of the modern hang-glider, designed so that the mass of the body could be moved to allow some degree of control. Despite many successful flights Lilienthal was killed in a flying accident on 9th August 1896, when he was 48 years old.

0.24 In 1885 a German by the name of Gottlieb Daimler developed the world's first single cylinder internal combustion engine which produced a power-to-weight ratio far superior to any other form of engine available for aircraft propulsion – the long awaited power plant for aircraft had finally arrived.



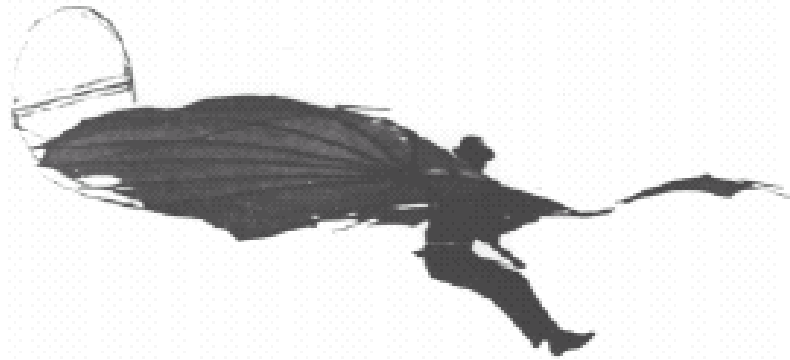

Otto Lilienthal flew well-built hang gliders

### The Beginning of Controlled Flight

0.25 On a cold Thursday morning on the 17th December 1903 Orville and Wilbur Wright rolled out their 'Flyer' for the first test flight. With Orville at the controls the Flyer flew a full 120 feet in controlled flight. Three other test flights followed the last and the best of that day covering 260m (852 ft) and ending with the elevator being damaged as the Flyer landed. Later Orville wrote: "The course of the flight up and down was exceedingly erratic. The control of the front rudder (elevator) was difficult. As a result the machine would rise suddenly to about ten feet, and then as suddenly dart for the ground. A sudden dart, when a little over 120 feet from the point at which it rose into the air, ended the flight."

0.26 The important feature of these flights was that man had been airborne and in control of a powered heavier-than-air machine for the very first time.

0.27 With improvements to the design of the Flyer, by the end of 1908 and flying from Auvours in France, Wilbur Wright had made more than 100 flights, totalling in excess of 25 flying hours. His last flight of the year, on 31st December lasted 2 hours 20 minutes during which time he covered a distance of 77 miles (124 km) to set a new world record and win the Michelin prize. While Wilbur was busy in Europe, Orville was demonstrating the Flyer at Fort Myer in Virginia. These demonstrations attracted and thrilled many thousands of people who came from miles around to see an aeroplane in flight. Tragically they ended after only a few weeks when the aircraft crashed, seriously injuring Orville and killing his passenger - **Lt Thomas E Selfridge - the first man in the world to be killed in a powered aircraft accident.**

### Historical points of Aviation History

- a. 400-300BC Chinese Fly Kites (first man made flying object);
- b. 200'sBC Archimedes discovers Buoyancy (main Theory behind aerostatic lift);
- c. 1452-1519 Leonardo da Vinci designs flapping wings but never proceeded in making them;

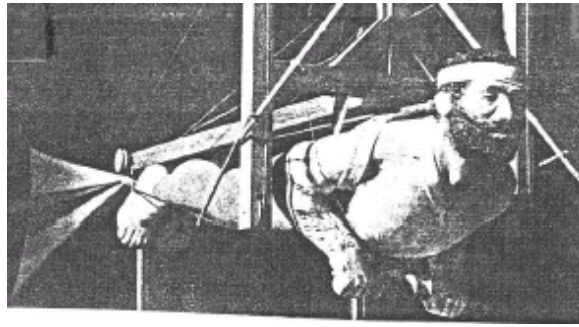

- d. 1687 Sir Isaac Newton publishes Third Law of Motion (important theory behind aerodynamic lift and thrust);
- e. 1700's Daniel Bernoulli's Theorem (main theory behind aerodynamic lift);
- f. 1783 The Montgolfier Brothers build the first manned Hot Air Balloon;
- g. 1804 Sir George Cayley flew the first successful model glider;



- h. 1891 Otto Lilienthal makes the first manned glider flight;



- i. 1903 Orville and Wilbur Wright make the first powered heavier than air flight;



- j. 1909 Louis Bleriot first man to fly the English Channel; and

- k. 1913 Igor Sikorski built and flew the first four engined plane;

## World War 1

0.28 By the time war was declared in August 1914, the leading nations' armed forces had already established air arms. The stimulus of war accelerated the development of aeroplanes and engines and the industry expanded rapidly.

0.29 Skirmishes between observation aircraft early in the war led to the development of more sophisticated gun technology such as the Fokker synchronised-gear machine gun, which ensures that bullets were fired between propeller blades. The SE5a was one of the most popular British fighters, which continued its career after the war. Bombing was adopted to a limited extent, with little military effect, but stimulated the design of much larger twin-engined aircraft. Some of these designs provided the basis for the first post-war airliners.

0.30 After World War One, new uses for aircraft were pioneered. The machine that made the biggest impact in 1919 was the Vickers Vimy bomber. A converted Vimy flown by Alcock and Brown made the first non-stop crossing of the Atlantic:

- a. 1919 Englishmen Alcock and Brown cross the Atlantic;



- b. 1919 Sir Ross and Keith Smith fly the Vickers Vimy from England to Australia in 27 days 20 hours. Airtime of 135 hours 55 minutes; and
- c. 1934 Sir Charles Kingsford-Smith and Charles Ulm fly from America to Australia, and Australia to New Zealand in the Southern Cross.

## World War II

0.31 In 1939, war again accelerated technological development in the aircraft industry. The Battle of Britain (1940) was a contest as much between engines as between aircraft. The Rolls-Royce Merlin engine, which powered both the Spitfire and Hurricane, represented the pinnacle of engineering design and production skill.

0.32 The most important development towards the end of the war was the jet. British and German teams raced to develop jet designs. In June 1944 Germany launched pilotless, explosive-carrying jet planes against Britain: the V-1, nicknamed the 'Doodle Bug' and 'Flying Bomb'. The first British fighter, the Gloster Meteor, entered service one month later in an effort to destroy the V-1s. In the late stages of the war Germany used the rocket-powered Messerschmitt Komet fighters to intercept enemy bombers.

- a. 1939 The first successful jet powered flight took place in Germany;



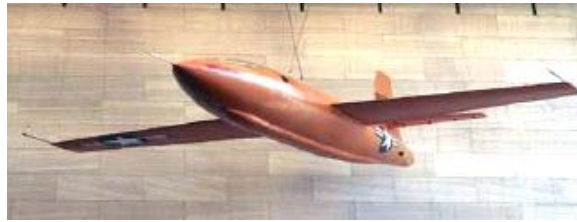

- b. 1947 The first Supersonic flight was made by Charles Yeager; and



- c. 1953 The North American F-100 Super Sabre made the first level supersonic flight by a jet plane.

### Civil and Commercial Aviation

0.33 Design, strength and power were the main ingredients that were needed to change the 'warbirds' into commercial airliners. Development of drag free bracing and struts, plus more powerful engines gave hope to a real change in aviation.

0.34 On 22 March, 1919, the first international passenger service between London and Paris was recorded. Such Companies as Air France, Deutsche, Lufthansa, Imperial Airways, KLM and Sabena were formed as national airlines.

0.35 Airliner development made great strides in the USA in the 1930s. Fast, all-metal monoplanes were developed by Northrop, Lockheed, Douglas and Boeing. Significant advances included the development of wing flaps (to improve low-speed lift and reduce landing speed), variable pitch propellers and retractable undercarriages.



0.36 1936 Douglas DC-3 aircraft entered airline service. They are the most widely used airliners in history;

0.37 1952 the world's first jet airliner was the de Havilland Comet 1, which flew in July 1949 and entered service in 1952. On long flights the Comet could halve the journey time of piston-engined airliners. Smooth and quiet, its pressurised cabin enabled it to fly in all weather conditions. The most successful aircraft of this first generation of jet airliners was the swept-wing Boeing 707, which entered service in 1958;

## Bigger or Faster?

0.38 In the 1960s commercial aviation began to follow two different paths – one leading to greater passenger-carrying capacity, the other to greater speed. The British and French governments funded a supersonic transport project, which eventually produced Concord – an aeroplane that can fly at twice the speed of sound, but has served with only two airlines, British Airways and Air France, because of its high operating costs.

0.39 In the USA Boeing started planning for an entirely different approach: a huge airliner with 400 seats. The resulting 747 produced a second revolution in jet transport and made international travel an almost commonplace experience.

- a. 1968 Russian pilots flew the world's first supersonic transport, the Tu-144;
- b. 1970 the first wide bodied airliner, the Boeing 747 entered airline service; and
- c. 1976 Concord, the British-French built Supersonic Transport (SST) aircraft enters service.

## Conclusion

0.40 The design and development of aircraft have come a long way from those early days of Lilenthal and the Wright brothers. There is no doubt that powered flight has, in less than a century, transformed the world. Journeys have shrunk from weeks to hours and travel across the world has become a possibility for everyone.

0.41 There will however, always be new challenges to meet and goals to aim for. In 1977 for example, Dr. Paul McCready's Gossamer Condor aircraft, powered and controlled by racing cyclist Bryan Allen, was flown in a figure-of-eight circuit around two pylons 0.8km (0.5 mile) apart.

0.42 This was the first significant man-powered flight, and won the £50,000 Kremer Prize which had been so long in finding a home. Dr. McCready's Gossamer Albatross aircraft went on in 1979, to set the world distance record for man-powered flight.

0.43 Aviation pioneers will always be with us testing new designs and pushing the frontiers of technology to their limits.



0.44 The progress made in aircraft design in the past 100 years has been breathtaking - who knows what the future holds!

## CHAPTER 2 – Basic Aviation

### SECTION 1 - Proficiency Flight Aviation Studies Objectives

#### Proficiency Flight 2.1

- a. Basic Year Revision
- b. Time:
  - (1) One 40 min theory lesson
- c. Scope / Range:
  - (1) History of aviation
  - (2) Major parts of an aircraft
  - (3) Aerodynamics
  - (4) Aircraft recognition
- d. Reference(s):
  - (1) NZCF 142

#### Proficiency Flight 2.2

- a. Aviation Careers
- b. Objective(s):
  - (1) Describe the various career opportunities that are available within Military and Civilian aviation
- c. Time:
  - (1) One 40 min theory lesson
- d. Scope / Range:
  - (1) Military careers
  - (2) Civilian careers
  - (3) Contact information
- e. Reference(s):
  - (1) RNZAF Recruiters
  - (2) RNZAF Website

- (3) Air New Zealand
- (4) ATTO Website
- (5) NZCF 142

### **Proficiency Flight 2.3**

- a. Airfield safety
- b. Objective(s):
  - (1) Outline airfield markings
- c. Time:
  - (1) One 40 min theory lesson
- d. Scope / Range:
  - (1) Airfield layout
  - (2) Airfield markings
  - (3) Safety on an airfield
- e. Reference(s):
  - (1) Visual flight guide
  - (2) NZCF 142

### **Proficiency Flight 2.4**

- a. Aircraft propulsion
- b. Objective(s):
  - (1) State the basic principle of operation of a four-stroke piston engine.
  - (2) State the basic principle of operation of a turbojet engine.
- c. Time:
  - (1) Two 40 min theory lessons
- d. Scope / Range:
  - (1) Reciprocating engine
  - (2) Gas turbine engine
- e. Reference(s):

- (1) Fenwick Chap 4
- (2) NZCF 142

### **Proficiency Flight 2.5**

- a. Cockpit layout
- b. Objective(s):
  - (1) Identify the major controls in an aircraft cockpit
- c. Time:
  - (1) One 40 min theory lesson
- d. Scope / Range:
  - (1) Primary controls
  - (2) Secondary flight controls
  - (3) Engine controls
  - (4) Instruments
- e. Reference(s):
  - (1) Fenwick Flying Training Manual
  - (2) NZCF 142

### **Proficiency Flight 2.6**

- a. Aircraft Instruments
- b. Objective(s):
  - (1) Describe the function of the basic flight instruments
- c. Time:
  - (1) One 40 min theory lesson
- d. Scope / Range:
  - (1) Basic flight instruments
  - (2) Engine instruments
  - (3) Other instruments
- e. Reference(s):

- (1) Fenwick Flying Training Manual
- (2) NZCF 142

### **Proficiency Flight 2.7**

- a. Airfield circuits
- b. Objective(s):
  - (1) Describe the circuit pattern
  - (2) Identify the parts of a circuit
- c. Time:
  - (1) One 40 min theory lesson
- d. Scope / Range:
  - (1) The circuit
  - (2) Upwind leg
  - (3) Crosswind leg
  - (4) Downwind leg
  - (5) Base leg
  - (6) Final approach
- e. Reference(s):
  - (1) Fenwick Flying Training Manual page 24
  - (2) NZCF 142

### **Proficiency Flight 2.8**

- a. Aviation Studies Test
- b. Time:
  - (1) One 40 min written test
- c. Test:
  - (1) Maximum of 30 questions
- d. Content:
  - (1) Test questions are to be raised from objectives covered in lessons PF 2.1 – PF 2.7.

- (2) Questions are to be a mix of short answer, multiple choice, fill in the gaps and true/false.
- e. Pass Mark:
  - (3) Minimum pass mark is 60% correctly answered

## SECTION 2 - Aviation Careers

### AIRCREW POSITIONS

- 2.1 Military aviation careers are not just limited to pilots or aircrew, but also include mechanics (electrical and mechanical).
- 2.2 Aviation careers available within the RNZAF today include the following:
- a. Pilot;
  - b. Navigator;
  - c. Air Engineer;
  - d. Air Electronics Operator;
  - e. Flight Steward;
  - f. Engineering Officer;
  - g. Avionics Technician;
  - h. Aircraft Technician;
  - i. Armament Technician;
  - j. Safety and Surface Worker;
  - k. Composites Technician;
  - l. Aeronautical Metal Worker; and
  - m. Machinist.

### Pilot

2.3 Pilots have one of the most exciting jobs in the world. They are trained not only to fly aircraft with the highest possible levels of professionalism, but also to respond calmly and quickly in just about any situation. It's a demanding job, one that requires a lot of training, study and hard work. But the rewards are there for those who put the effort in.

### Navigator

2.4 A Navigator is responsible for being the 'eyes and ears' of the pilots. They use the latest equipment to plot courses and supply positions and information throughout flights in Orions and Hercules.

### Air Electronics Operator (AEOP)

2.5 AEOPs use the electronic equipment and sensors on board the Orion aircraft to perform such tasks as submarine tracking, radar detection of surface targets, infrared camera and video surveillance. The AEOPs role is to operate the equipment and interpret



the results, as well as operating communications equipment. As an integral part of the crew, the AEOP works closely with Pilots, Navigators, Air Engineers, Air Ordnance and other AEOPs on the aircraft.

### **Flight Steward**

2.6 The Flight Steward works on the new Boeing 757 and their role includes boarding passengers, providing for their welfare, securing cabins, prepare, provide and clear in-flight service (including meals and refreshments), provide VIP service, take action in the event of an emergency and to participate in various support duties for the aircrew. A Flight Steward needs good communication and group relations skills, must display a high level of maturity and maintain a solid dedication to the RNZAF and their job.

### **NON DIRECT ENTRY AIRCREW POSITIONS**

2.7 Other Aircrew positions such as Air Engineer, Air Ordnance, and Air Loadmaster are sourced from suitably qualified personnel within the RNZAF and as such there is no direct entry for these positions.

### **Air Engineer**

2.8 The air engineer is an integral part of the crew in both Hercules and Orions. They monitor the aircrafts engines and systems and also carry out basic maintenance on the aircraft while the aircraft is away from its home base.

2.9 People to fill this position are normally selected from either Avionics Technicians or Aircraft Technicians.

### **Air Ordnance**

2.10 The Air Ordnance person works on the Orion and is in charge of the weapons and Sonar buoys that are carried on the aircraft.

2.11 People to fill this position are normally selected from the Armament Trade.

### **Air Loadmaster**

2.12 The Air Loadmaster works on the Hercules and the 757 to ensure the loads that are carried are of the correct size and weight and are carried in the correct position. They are also responsible for the dropping of loads from the rear of the Hercules and ensure they are set up correctly for safe extraction.

2.13 People to fill this position are normally selected from the Supply trade.

### **NON AIRCREW POSITIONS**

### **Engineering Officer**

2.14 The Engineering Officer is ultimately responsible for the standard of maintenance of the Air Forces aircraft and their systems. As an Officer they are also required to show excellent command and leadership skills.

### **Avionics Technician**

2.15 Avionics Technicians are a part of the ground crew responsible for the maintenance, service and repair of all electrical systems and components on the aircraft.

### **Aircraft Technician**

2.16 Aircraft Technicians are an essential part of the ground crew responsible for the maintenance, service and repair of all mechanical components, airframes and engines on the Air Force aircraft.

### **Armament Technician**

2.17 Armament Technicians are a part of the ground crew responsible for the maintenance, service and repair of all armament systems and components on the aircraft. They are also responsible for maintaining all the weapons in the Air Forces inventory.

### **Safety and Surface Worker(S&S)**

2.18 The S&S Worker actually covers two essential roles within the Air Force. One of which is survival equipment maintenance, such as helmets, oxygen masks, life rafts, flares and survival kits. The second role is that of aircraft finisher, which involves looking after the interior and exterior surfaces of the aircraft.

### **Aeronautical Metalworker**

2.19 The Aeronautical Metalworker is taught all facets of metal fabrication and methods of working with materials such as Steel, Stainless Steel, Aluminium, Titanium, Nimonic and Chrome-moly steels. Aeronautical Welding and General Engineering are the two main focuses of their work.

### **Composites Technician**

2.20 Composites Technicians are part of the ground crew responsible for the maintenance, repair and fabrication of composite and metal bonded components.

### **Machinist**

2.21 The machinist is involved in the fabrication and repair of aeronautical components for all Air Force aircraft. They are trained to operate a large variety of machines to very high standards.

### **Educational Qualifications**

2.22 For the specific qualifications for the positions listed above see the recruiting brochures attached at rear of the handout or contact your local RNZAF recruiter by calling 0800 AIR FORCE (0800 247367).

### **CIVILIAN CAREERS**

2.23 There is also a large range of aviation related careers that are available in the civilian world. Some of these are listed below:

- a. Aeroplane Pilot;
- b. Agricultural Pilot;
- c. Air Traffic Controller;
- d. Airport Maintenance Worker;
- e. Flight Attendant;
- f. Flying Instructor;
- g. Helicopter Pilot;
- h. Aircraft Loader/Cleaner;
- i. Aircraft Refueller;
- j. Aircraft Engineer;
- k. Aeronautical Engineer; and
- l. Avionic Engineer.

2.24 Information on how to start on your goal towards any one of the above careers can be found at the [www.attto.org.nz](http://www.attto.org.nz) website.

### **Pilots**

2.25 The starting point is at your local aero club with a goal of your Private Pilots Licence (PPL). After gaining your PPL you can move on towards your Commercial Pilots Licence (CPL) and your instructor rating. This can also be done through you local Aero Club.

### **Air Traffic Controllers**

2.26 The Air Traffic Controller directs the safe and orderly movement of aircraft while they are flying, landing, taking off or taxiing. The Airways Corporation runs National Certificate in Air Traffic Services.

### **Airport Maintenance Worker**

2.27 The Airport Maintenance Worker maintains airport grounds and buildings. A National Certificate in Airport Operations is available and training is carried out on the job at various airports around the country.

### **Flight Attendant**

2.28 A Flight Attendant takes care of the passengers' needs and safety while they are in the aircraft. Training for a National Certificate in travel or a specific Flight Attendants course can be carried out at a Polytechnic, with a private provider or on the job with an airline such as Air New Zealand.

### **Aircraft Loader/Cleaner**

2.29 Aircraft Loader/Cleaners load and unload aircraft, transfer freight, baggage and passengers between airport buildings and the aircraft. They also clean the inside of the aircraft between flights. On the job training is supplied with the aim of completing the National Certificate in Airport Operations.

### **Aircraft Refueller**

2.30 The Aviation Refueller replenishes aircraft with fuel at the various airports around the country. On the job training is carried out with the aim of completing the National Certificate in Airport Operations.

### **Aircraft Engineer**

2.31 The Aircraft Engineer maintains and repairs the engine, body and wings, etc of an aircraft. Training is provided through private providers, on the job training and the modern apprenticeship scheme with the aim of completing the National Certificate in Aeronautical Engineering.

### **Aeronautical Engineer**

2.32 The Aeronautical Engineer provides technical support and approved technical data for use in repair, maintenance and modification of aircraft. Training is provided through private providers, on the job training and the modern apprenticeship scheme with the aim of completing the National Certificate in Aeronautical Engineering.

### **Avionics Engineer**

2.33 The Avionics Engineer maintains and repairs an aircraft's electrical, instrument and radio systems. Training is provided through private providers, on the job training and the modern apprenticeship scheme with the aim of completing the National Certificate in Aeronautical Engineering.

2.34 There are various websites that can be visited to find out more information on any of the careers that are listed above and the many more that are not. Some suggested websites to visit are:

- a. [www.airnewzealand.com](http://www.airnewzealand.com)
- b. [www.caa.govt.nz](http://www.caa.govt.nz)
- c. [www.attto.org.nz](http://www.attto.org.nz)
- d. [www.airforce.mil.nz](http://www.airforce.mil.nz)
- e. [www.airways.co.nz](http://www.airways.co.nz)

2.35 These are just some of the sites that can provide information on aviation careers. Most of these sites will have links to other relevant sites. Make the most of these sites and their links to find out more.

## SECTION 3 - Airfield Safety

### AIRFIELD LAYOUTS

#### General Layout

2.36 Airfields are so placed as to assist the smooth flow of aircraft movement on the ground and in the air. Runways are placed to take into account the local prevailing winds so aircraft can have consistent "into wind" landing and takeoff conditions most of the time.

2.37 Built up areas are also taken into account as in the case of emergency, aircraft must be given adequate opportunity to land in the event of a engine failure.

2.38 The layout of a typical airfield provides for ground movement of aircraft to their specific runways via taxiways leading to or alongside of the runway and generally includes run-up bays for preflight checks

2.39 Windsocks are placed so that pilots can check wind direction from both on the ground or overlying an airfield. The diagram below is a simple airfield layout.

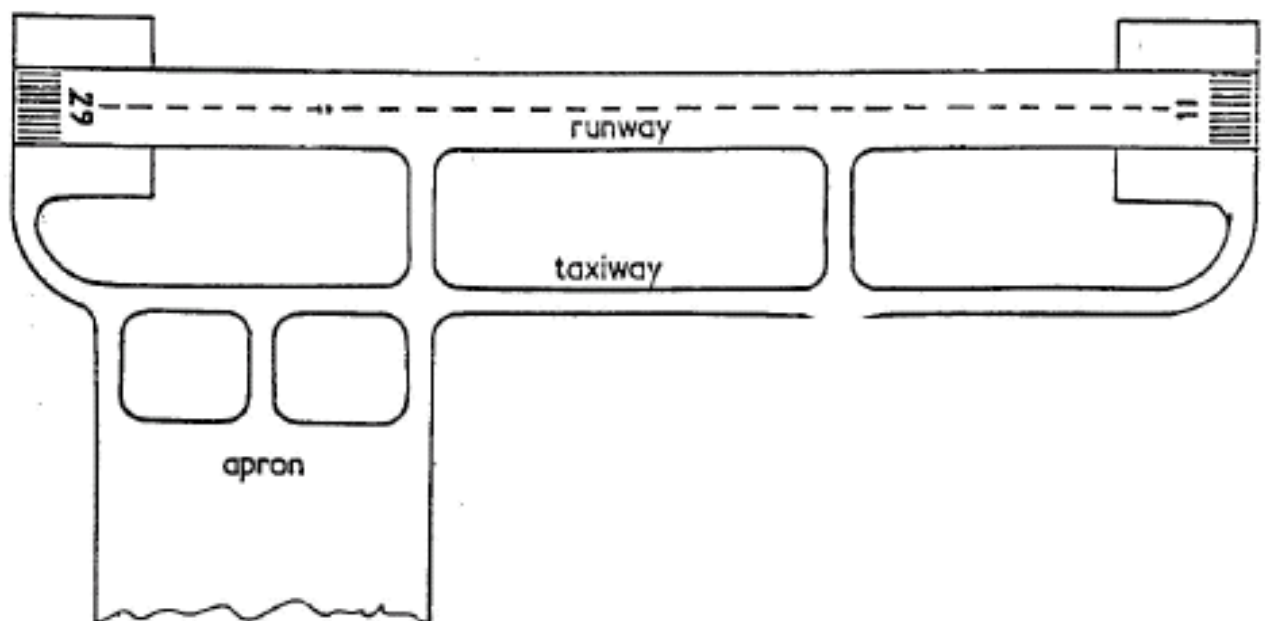

Fig 2-1 Basic Airfield Layout

#### Taxiway Markings

2.40 Taxiway markings are painted in yellow. Taxiway centre lines may be painted with a continuous yellow line.

2.41 Taxiway edging may be painted with a double yellow line to mark the difference between soft and hard holding surfaces.

2.42 Taxiway holding lines are painted across the width of the taxiway, one line continuous, the other a dashed line. Sometimes a holding SIGN may be located on the edge of the taxiway, with white letters on a red background.

2.43 Cone markers or gable markers may also be used to mark the boundaries of taxiways, tarmac aprons and runways. An alternative is a solid painted line.

### Holding Bay

2.44 Prior to take-off an engine run-up is required to check various instruments and controls; this is done in a holding bay. These bays may be marked in the same way as the taxiway.

## RUNWAY AND TAXIWAY MARKINGS

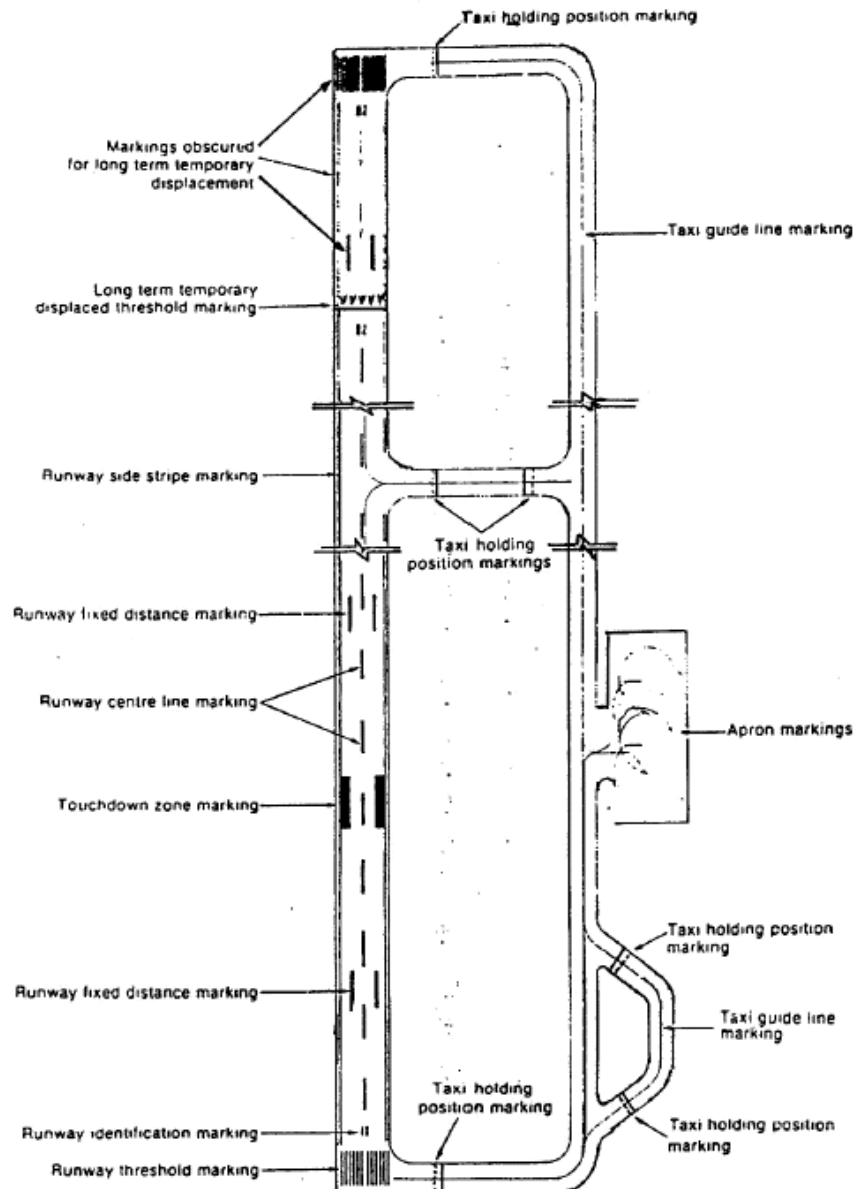

Fig 2-2 Basic Airfield Markings

### Permanent Threshold

2.45 This marking is used at the end of sealed or concrete runways. Referred to as "Piano Keys", (consisting of a series of parallel longitudinal white lines) they are always

used when the width of the runway is 30 metres or more. The marking is sometimes used for runways of less width.

### Runway Side Stripe and End Markings

2.46 A solid white line indicates the edges of a sealed or concrete runway.

### Unusable Runways

2.47 A totally unusable runway will have a large white cross (X) at each end.



Fig 2-3 Unusable Runway Markings

### Helipad Marking

2.48 Helipads are indicated with a large white circle.



Fig 2-4 Helipad Markings

### PRECAUTIONS ON TARMAC AND AROUND AIRCRAFT

2.49 This section mainly refers to either visits to airports, or as part of a maintenance crew working on flight lines or tarmac areas on both civilian and military airfields. In both cases the following precautions should be observed:

- a. **BEWARE** of propellers, always treat them as LIVE and do not touch or move them unless you are qualified to do so;
- b. **BEWARE** of jet engine intake suction, always stay well clear and outside of the designated "Danger" area. Most jet engines have their particular danger zone area painted on the side of the engine cowling in red; and
- c. **BEWARE** of jet blast, this normally is a much larger danger area than intake suction. The jet blast area will vary with engine speed.

2.50 When working or moving around a manned aircraft be careful of the following:

- a. Speed brakes;
- b. Bomb bay doors;

- c. Ejection seats;
- d. Operating radar domes; and
- e. Any armament on or around the aircraft.

**DON'T:**

- a. Smoke near aircraft;
- b. Carry loose objects in unzipped or unbuttoned pockets;
- c. Play with propellers;
- d. Put hands in or on control surfaces; or
- e. Step on 'NO STEP' areas.

2.51 Always watch out for other traffic on the tarmac like towed aircraft, maintenance vehicles, fuel tankers, catering trucks and general tarmac approved vehicles.



## SECTION 4 - Aircraft Propulsion

### Introduction

2.52 All Aircraft require some form of engine to provide propulsion. Two engine types commonly used are:

- a. Reciprocating Engines; and
- b. Gas Turbine Engines. Gas Turbines are discussed in the next chapter.

2.53 The majority of light aircraft operating in New Zealand use an air-cooled four stroke reciprocating engine as their motive power, so it is only fitting we have a look at the basic operating principles of the four stroke engine.

### FOUR STROKE CYCLE

2.54 All internal combustion engines have a sequence of events that must take place to convert the chemical energy of the fuel into mechanical energy and work. Most aircraft engines use the four stroke cycle, consisting of the following strokes:

- a. Induction;
- b. Compression;
- c. Combustion; and
- d. Exhaust.

### Induction (Suck)

2.55 The inlet valve is opened. Fuel and air are taken into the engine as the piston descends.

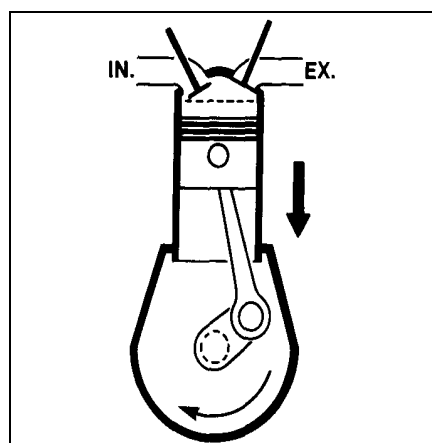

Fig 3-1 Induction Stroke

### Compression (Squeeze)

2.56 When both valves are closed, the fuel-air mixture is compressed as the piston rises.

Error! Objects cannot be created from editing field codes.

Fig 3-2 Compression Stroke

### Combustion (Bang)

2.57 When both valves are closed and the fuel/air mixture compressed, it is ignited by the spark plug. The burning gases expand and drive the piston down producing work.

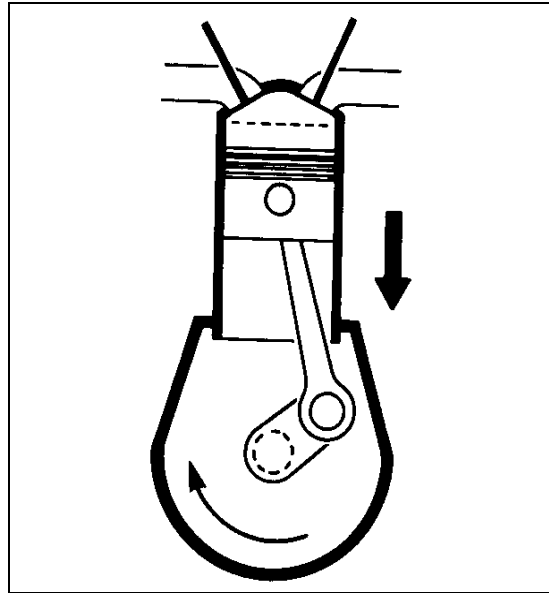

Fig 3-3 Combustion Stroke

### Exhaust (Blow)

2.58 The exhaust valve is opened and the combusted gases are released as the piston rises.

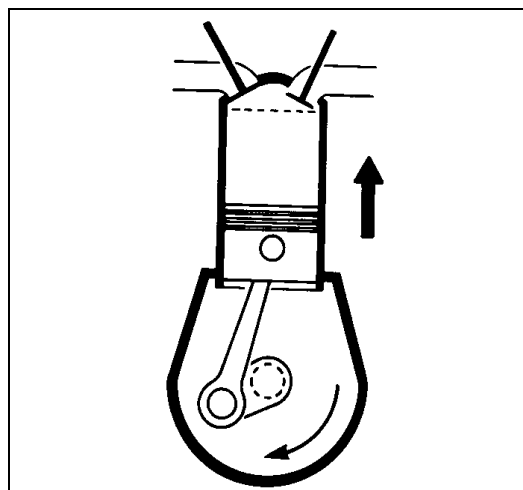

Fig 3-4 Exhaust Stroke

2.59 The piston then repeats the process as long as there is fuel and an ignition spark. It must be appreciated that there is normally more than one piston in an engine; therefore each piston will be at a different stage of the cycle.

## MAJOR COMPONENTS

### Crankcase

2.60 The crankcase is the foundation of the engine that houses or provides attachment points for all the other assemblies. It must provide a tight enclosure for the lubricating oil.

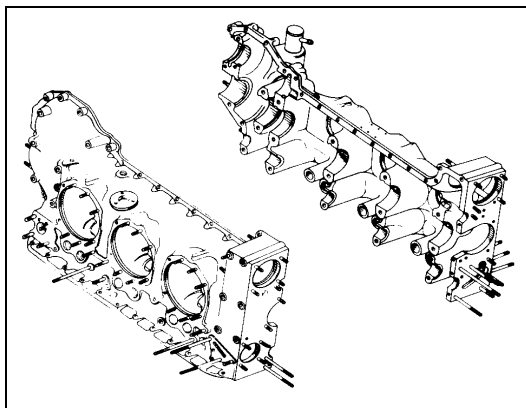

Fig 3-5 Crankcase Halves

### Crankshaft

2.61 The main purpose of the crankshaft is to transform the reciprocating motion of the piston and connecting rod to the rotary motion of the propeller.

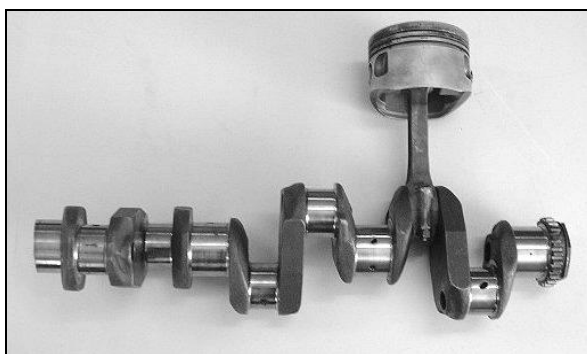

Fig 3-6 Crankshaft, con rod and piston

### Connecting Rods

2.62 The connecting rod is the link that transmits the forces from the piston to the crankshaft.

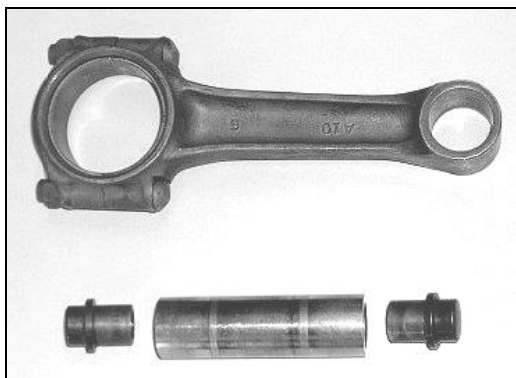

Fig 3-7 Connecting Rod Assembly

## Pistons

2.63 The piston moves within the cylinder and acts as a moveable wall for the combustion chamber. Rings are used to provide a gas seal.

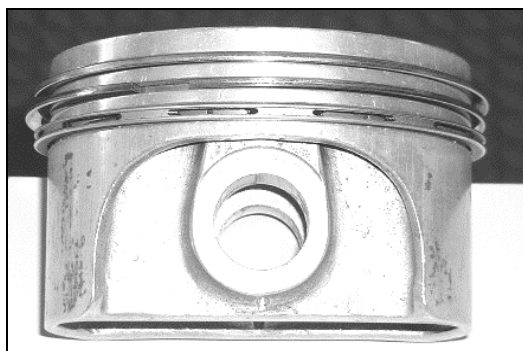

Fig 3-8 Piston

## Cylinders

2.64 Power in an engine is developed in the cylinder. The cylinder provides a combustion chamber where the burning and expansion of gases takes place.

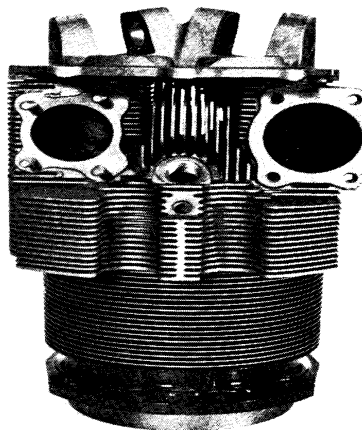

Fig 3-9 Air Cooled Engine Cylinder

### Valve Operating Mechanism

2.65 For a reciprocating engine to operate properly, each valve must open at the proper time, stay open for the required length of time, and close at the proper time. The timing of the valves is controlled by the valve operating mechanism.

2.66 The fuel/air mixture enters the cylinder through the intake valve ports, and burned gases are expelled through the exhaust valve ports.

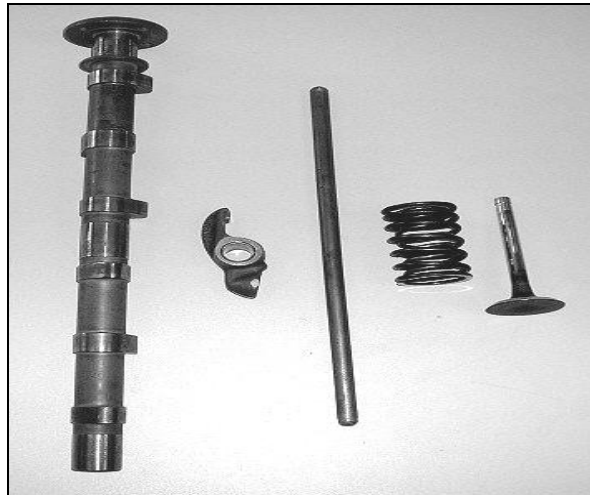

Fig 3-10 Valve Train Components

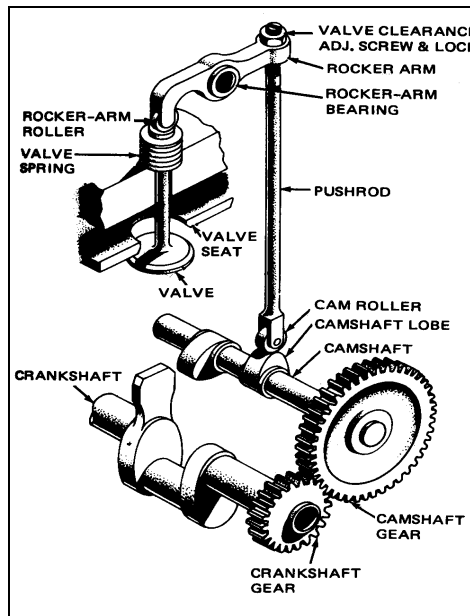

Fig 3-11 Valve Operating Mechanism

### IGNITION SYSTEM

2.67 The purpose of the ignition system is to provide high voltage electricity to ignite the fuel/air mixture in the cylinders of the engine at the correct time in the 4 stroke cycle.

Error! Objects cannot be created from editing field codes.

Fig 3-12 Ignition system

2.68 The main parts of the ignition system are:

- a. Magneto;
- b. High Tension Leads; and
- c. Spark plugs.

### Magneto

2.69 Magnetos generate high voltage electricity and then direct this high voltage to the correct cylinder to ignite the fuel/air mixture.

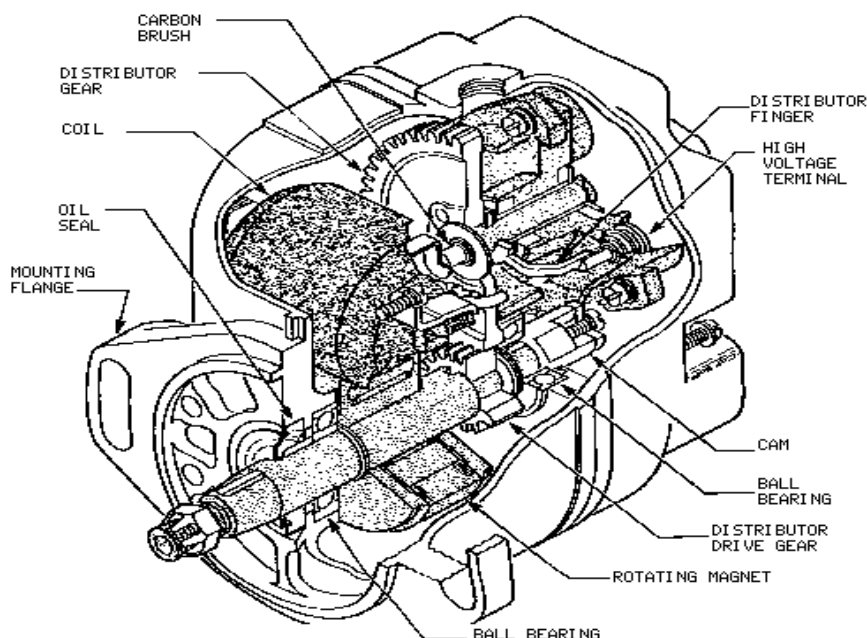

Fig 3-13 Magneto

### High Tension (HT) Leads

2.70 Delivers high voltage electricity from the magneto to the spark plugs.

### Spark Plugs

2.71 Provides a gap over which the high voltage spark jumps to ignite the fuel/air mixture in the cylinders.

Error! Objects cannot be created from editing field codes.

Fig 3-14 Spark Plug

**FUEL SYSTEM**

2.72 The purpose of the Engine Fuel System is to supply the fuel/air mixture to the engine in all flight conditions. Two types are used:

- a. Carburettor; and
- b. Fuel Injection.

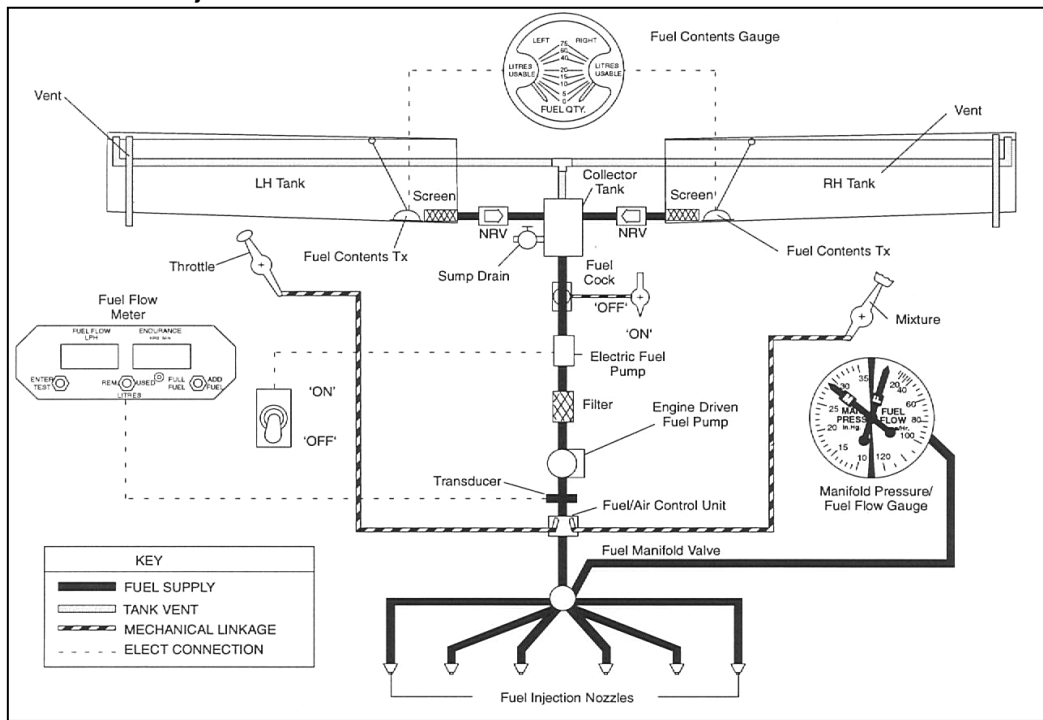

Fig 3-15 CT – Air-trainer Fuel System

## SECTION 5 - Gas Turbine Engines

### Introduction

2.73 The majority of larger aircraft and most military aircraft operating around the world today use a gas turbine engine as their primary method of propulsion.

### OPERATING PRINCIPLES

#### Newton's 3<sup>rd</sup> Law

2.74 The operating principle of a Gas Turbine Engine (GTE) can be explained by Sir Isaac Newton's 3<sup>rd</sup> law of motion '**for every action, there is an equal and opposite reaction**'. A simple demonstration of this principle is a balloon. When released the balloon flies in the opposite direction to the escaping air.

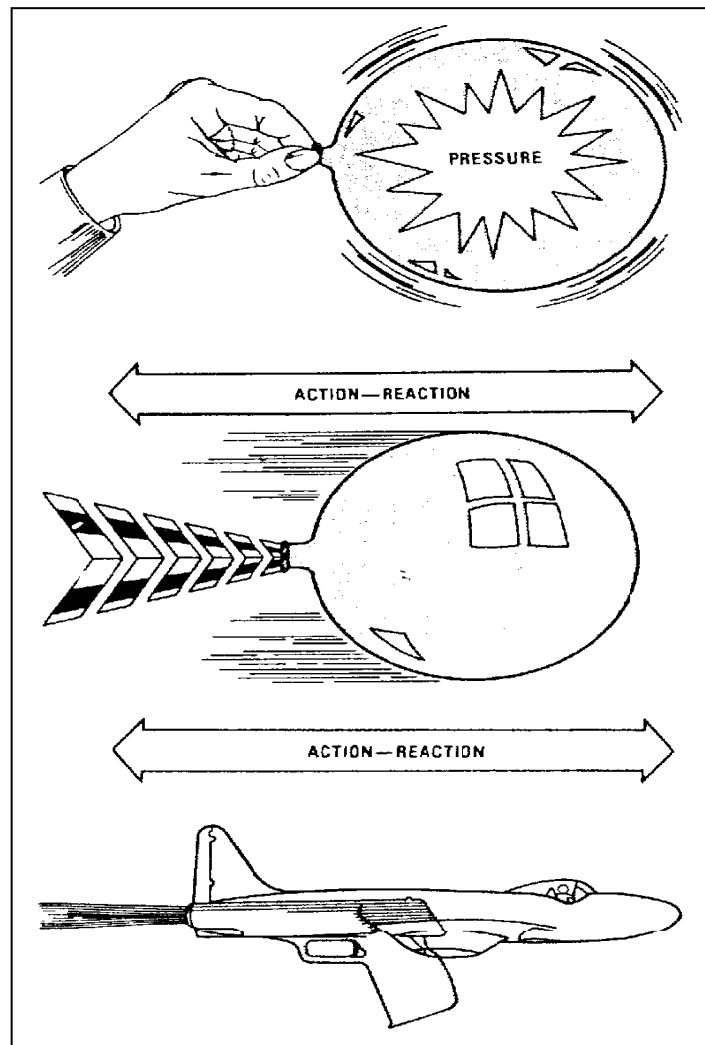

Fig 4-1 Isaac Newton's 3<sup>rd</sup> law

2.75 In a jet engine the action is air being accelerated through the engine. The reaction is the movement of the aircraft in the opposite direction.



## Gas Turbine Engine (GTE) Operation

2.76 The GTE is a device that is used to accelerate a flow of gas rearward to provide an action/reaction.

2.77 The events occurring in the turbine engine are basically the same as those that occur in a piston engine, with the main difference being that in a turbine engine all events are occurring simultaneously. The four continuous events are:

- a. **Induction:**
  - (1) Air is induced into the engine by the compressor.
- b. **Compression:**
  - (1) Air is compressed by the compressor, and air pressure is increased.
- c. **Combustion:**
  - (1) The compressed air is heated in the combustion section.
  - (2) The gasses expand and as they cannot go forward, accelerate rearward.
  - (3) The accelerated gasses pass through the turbine where a portion of the energy is extracted to drive the compressor.
- d. **Exhaust:**
  - (1) The remaining gasses exhaust through the rear of the engine, providing thrust.

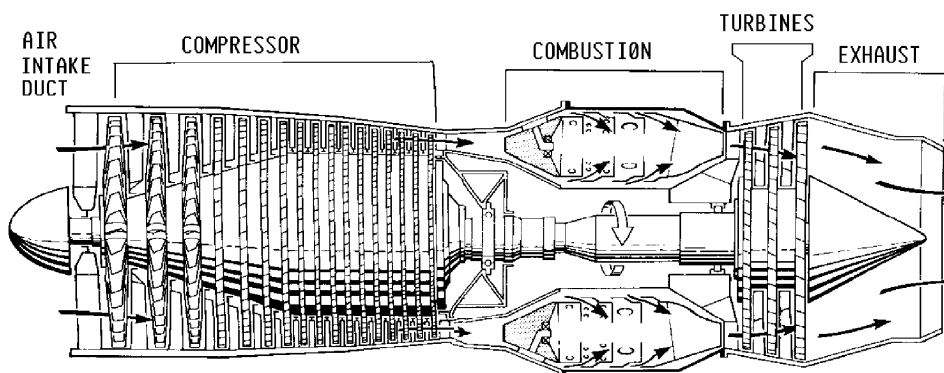

Fig 4-2 Axial Flow Gas Turbine Engine Sections

## GAS TURBINE ENGINE CONSTRUCTION

### Compressor Section

2.78 The compressor induces and compresses air above atmospheric pressure prior to combustion. The rotor spins within the casing and has many blades. Each rotor disc is called a stage, and each stage is numbered from the front of the engine.

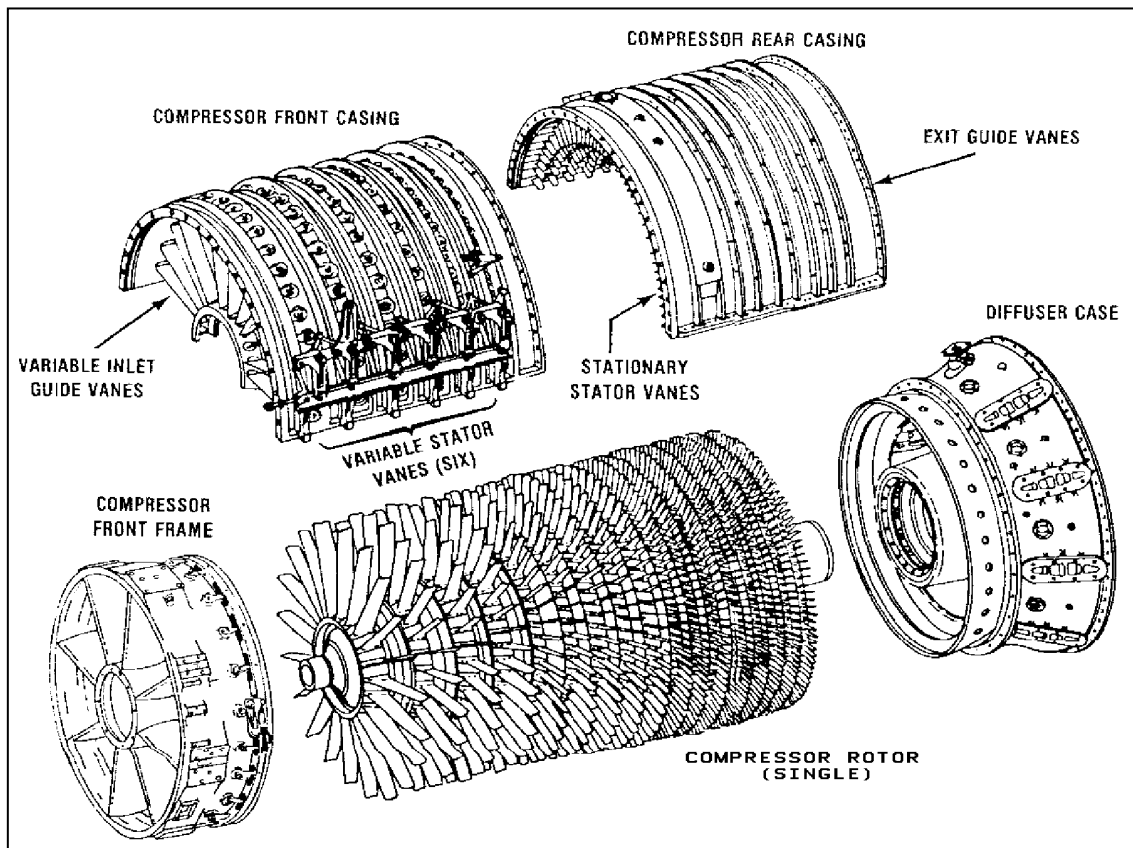

Fig 4-3 Compressor Section

2.79 Some engines have guide vanes attached to the case that do not spin, but are used to smooth the airflow within the engine.

### Combustion Section

2.80 The combustion section adds heat energy to the gases, making them expand and accelerate, by injecting and burning fuel. The fuel system ensures that allowable temperatures are not exceeded.

2.81 Combustion chambers are lighter than those in a reciprocating engine as the pressure is less in a GTE.

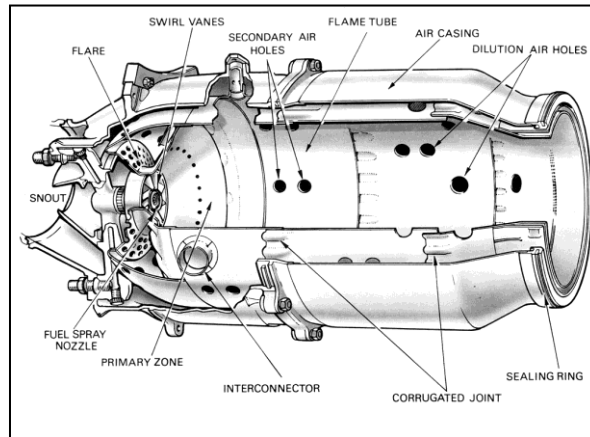

Fig 4-4 Gas Turbine Combustion Chamber

### Turbine Section

2.82 The turbine section is similar to the compressor in that it has a series of blades that are exposed to the airflow. These blades are driven by the exhausting gasses to drive the compressor and engine accessory gearboxes.

2.83 The turbine provides the power to rotate the compressor and operate the various components necessary to keep the gas turbine functioning, such as pumps, control units etc.

2.84 Depending on the type of GTE, the turbine section can vary in size. (Turbo-props have a much bigger turbine section than a Turbo-jet as the turbine must drive the propeller).

2.85 As the turbine absorbs most of the energy created by combustion, it is the most highly stressed component in the engine.

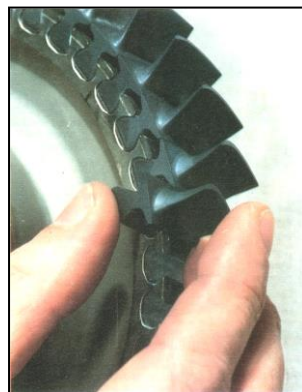

Fig 4-5 Turbine Blades

### Exhaust Section

2.86 The exhaust section ducts the gas flow from the turbine and clears it from the aircraft structure. It is also designed to provide thrust for Turbo-jet and Turbo-prop engines.

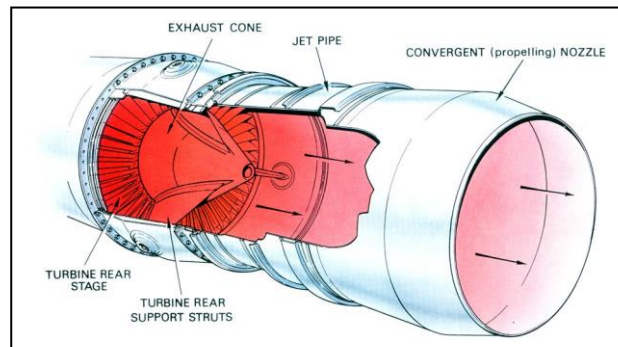

Fig 4-6 Exhaust Section

## GAS TURBINE ENGINE SYSTEMS

2.87 A gas turbine engine must use the following systems to start, monitor and sustain its operation:

- a. Fuel System.
- b. Lubrication System.
- c. Starting System.
- d. Internal Air System.

### Fuel System

2.88 Unlike reciprocating engines, GTEs do not use carburetors. Fuel must be provided at high pressures and so high pressure fuel pumps and fuel control units are used.

2.89 Fuel control units sense many different pressures, temperatures and other inputs to ensure the correct amount of fuel enters the combustion chambers at all times.

### Lubrication System

2.90 The function of the lubrication system is to reduce friction between moving parts, absorb heat and collect foreign matter as it circulates through the engine.

2.91 As a gas turbine system does not lubricate components involved with combustion, a smaller oil tank is required when compared to that of a reciprocating engine.

### Starting System

2.92 During an engine start cycle there are three systems operating simultaneously:

- a. Starter;
- b. Ignition; and

- c. Fuel.

2.93 Once the starter has rotated the engine to a set RPM, the fuel and ignition systems are activated.

2.94 Once at idle, the starter is dis-engaged. The ignition system is also turned off as once combustion is initiated, the flame in the combustor is continuous, therefore, a spark is not needed.

### Internal Air System

2.95 The internal air system is used to cool hot engine regions and prevents ice build-up at the front of the engine.

### TYPES OF GAS TURBINE ENGINE

2.96 The main types of gas turbine engine are:

- a. Turbo-jet.
- b. Turbo-prop.
- c. Turbo-shaft.
- d. Turbo-fan.

### Turbo-jet

2.97 The Turbo-jet uses its exhaust to provide the engines thrust. It is the least fuel-efficient and is used in older jet aircraft such as the A-4K Skyhawk and Boeing 727.

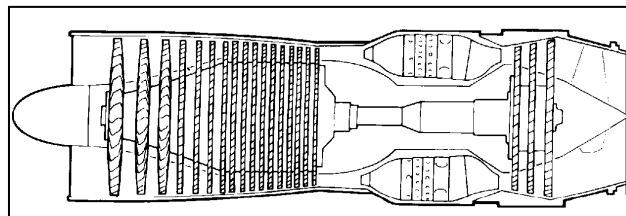

Fig 4-7 Turbo-Jet Engine

### Turbo-prop

2.98 The turbo-prop is very efficient at producing thrust and is widely used for low speed aircraft. The propeller is rotated by a turbine or by gearing from the compressor. It is used on P-3 Orions, C-130 Hercules and King Airs.

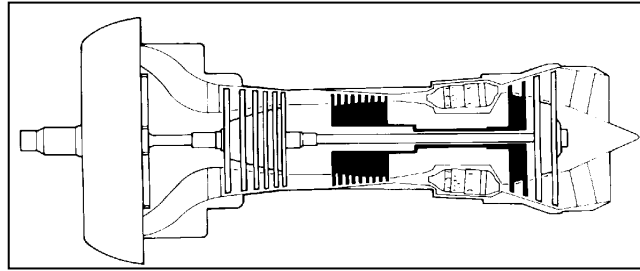

Fig 4-8 Turbo-Prop Engine

### Turbo-shaft

2.99 Turbo-shaft engines have a shaft arrangement instead of a fan or propeller. This shaft can drive a variety of components such as helicopter rotors, ship propellers and power station generators. The shaft is usually powered by a large turbine assembly.

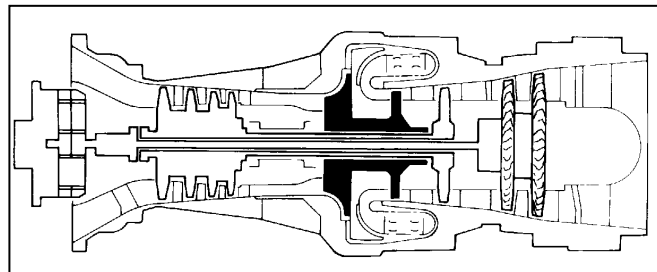

Fig 4-9 Turbo-shaft Engine

### Turbo-fan

2.100 This GTE is similar to a turbo-prop, but has a fan in place of a propeller. It is much more efficient than a turbo-jet and enormous amounts of thrust can be developed.

2.101 Turbofans are used in most modern medium/high speed commercial and military aircraft, from B757s to the latest fighters.



Fig 4-10 C-17 with Turbo-fan Engines



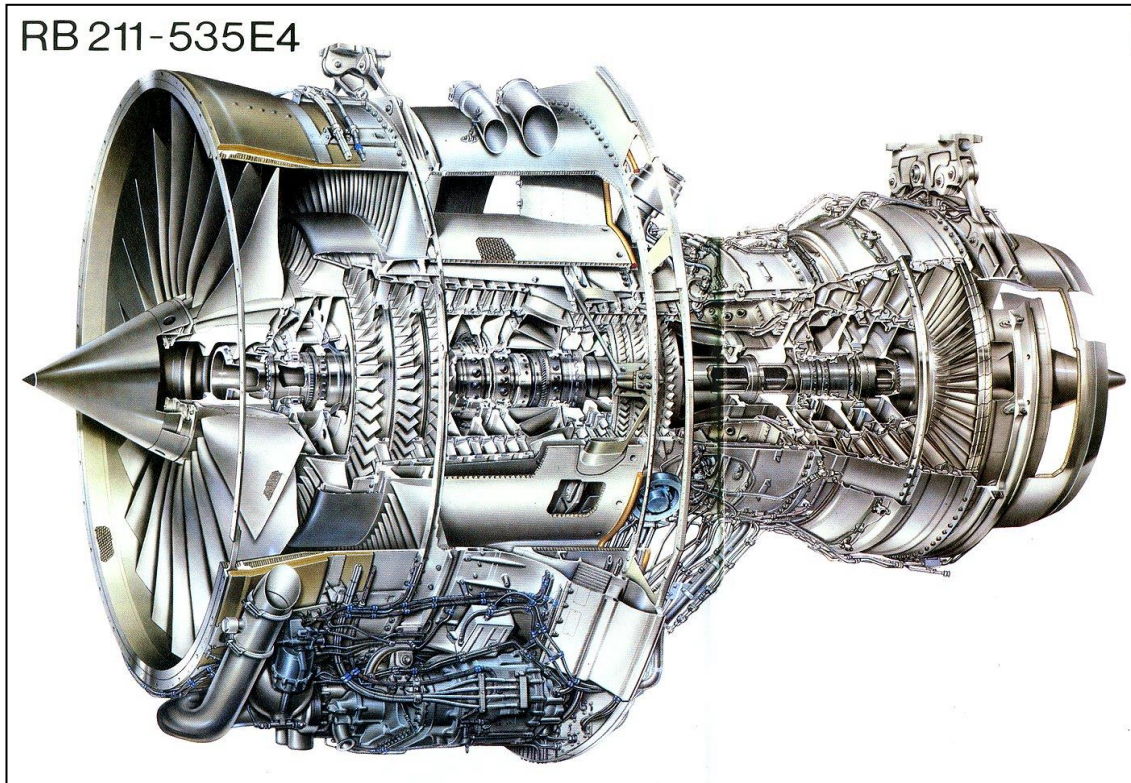

Fig 4-11 Rolls Royce RB211 Turbo-fan Engine



## SECTION 6 - Cockpit Layout

### Introduction

2.102 All aircraft have a requirement for specific controls and instruments to be available in the cockpit of an aircraft to enable the pilot to safely fly and navigate the aircraft.

2.103 The basic controls and instruments don't really vary considerably between different aircraft. Larger, more complex aircraft will have extra instruments, especially multi engine ones, but the basic controls and instruments will always be there.

### Primary Controls

2.104 The primary flight controls are the Ailerons, Elevators and the Rudder. These are controlled from two points within the cockpit. The control column (joystick) controls the ailerons and elevators. The rudder is controlled by the rudder pedals, which are operated by the pilot's feet.

2.105 The other primary control is the throttle as this is required for control of power and thrust.

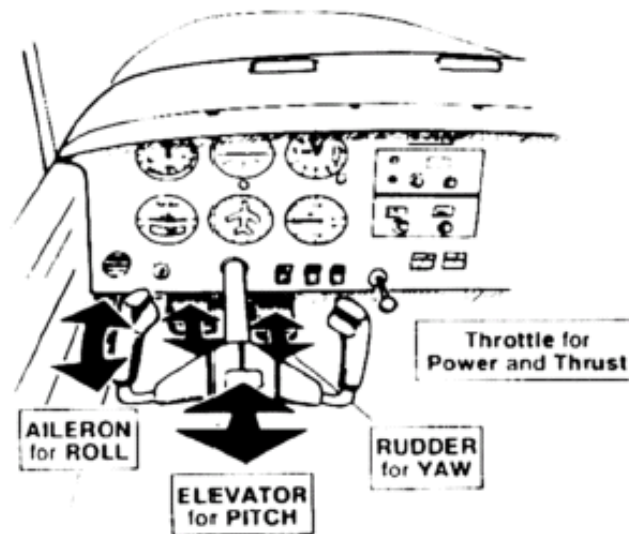

Fig 5.1 Light Aircraft Primary Controls

### Secondary Flight Controls

2.106 Secondary flight controls include flaps, slats, spoilers and speed-brakes. Most of these controls will not be found on General Aviation (GA) aircraft, but you will almost always find flaps on GA aircraft.

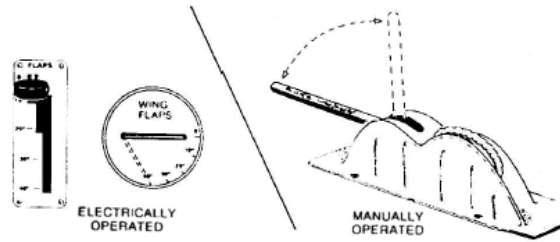

Fig 5-2 Flap Controls

### Engine and Other Controls

2.107 The main engine control is the throttle, which controls the power, and the thrust of the engine, also alongside the throttle there is normally located the mixture control and the carb heat control.

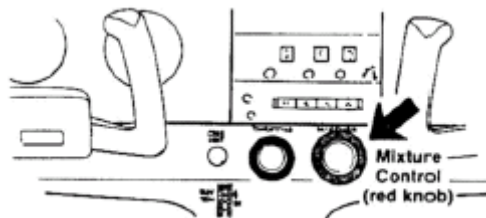

Fig 5-3 Throttle and Mixture Controls

2.108 Cabin ventilation and heating controls are located either side of the instrument pane or on the cabin sides. See below for basic layout of heating and ventilation system on a GA aircraft.

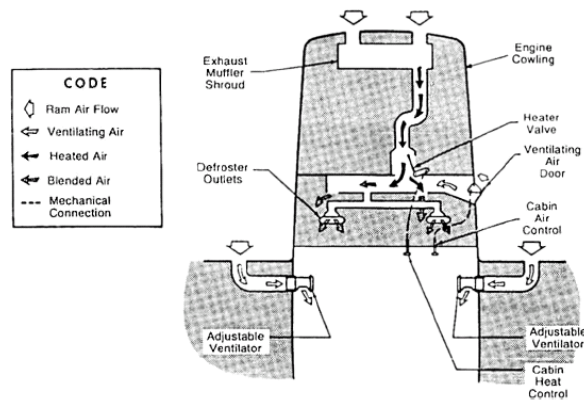

Fig 5-4 Cockpit Ventilation System

2.109 The main switches on the panel are the ignition/magneto switch, VHF- Com radio switch and the fuel selector switch located on a console between the seats.

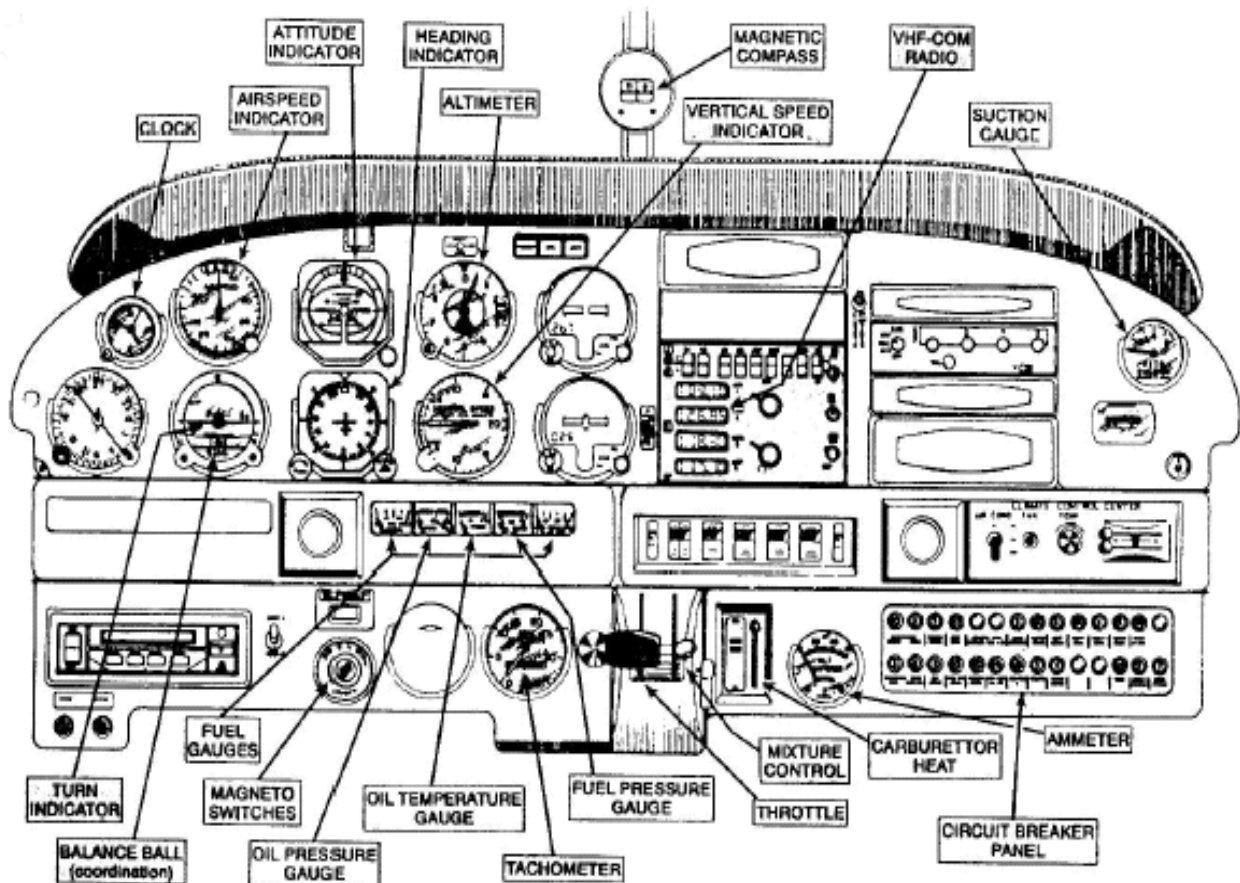

Fig 5-5 Basic GA Instrument Panel Layout

## Instruments

2.110 The main flight instruments are directly in front of the pilot. They consist of the airspeed indicator, attitude indicator, altimeter, vertical speed indicator, a heading indicator and a turn indicator.

2.111 Engine instruments are normally grouped together in a horizontal or vertical row and for each engine the instruments will be replicated. Engine instruments will normally include RPM (tachometer), Oil pressure, Oil temperature, Fuel pressure, Fuel quantity and may also include Cylinder Head temperature (CHT). See diagram above

## SECTION 7 - Aircraft Instruments

### Introduction

2.112 In the days of the first successful aeroplanes the problems of operating them and their engines according to strict and complicated procedures, of navigating them over long distances day or night under all weather conditions were of course problems for the future.

2.113 They were no doubt envisaged by the then enthusiastic pioneers of flight, but were perhaps overshadowed by the thrills of taking to the air, manoeuvring and landing. Flights were only made in the best weather and during the day over very short distances.

2.114 As other pioneers entered the field, many diverse designs, some of which provided an enclosure for the pilot and a wooden board to mount what few instruments were then available. Thus the instrument panel was born.

2.115 Safe, economical and reliable operation of modern aircraft is dependent upon the use of instruments.



Fig 6-1 Devon Aircraft Cockpit

### Purpose of Instruments

2.116 To record various information and relay that information to the pilot in a visual manner.

2.117 Some of the information that is recorded:

- a. Speed
- b. Distance
- c. Altitude
- d. Attitude
- e. Direction
- f. Temperature
- g. Pressure

h. RPM

2.118 Instruments are normally grouped on the panel according to their function e.g. Navigation, Engine, and Basic Flight Instruments.

2.119 Basic Flight Instruments are those instruments that are the minimum required to safely fly the aircraft in poor visibility and at night.

2.120 These instruments are grouped together on a panel known as the **Blind Flying Panel**. All aircraft have this panel regardless of type or size.

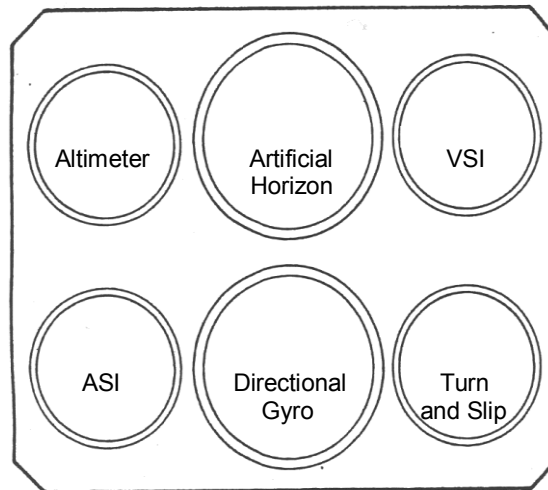

Fig 6-2 Blind Flying Panel

2.121 The **Six Flight Instruments** that are found on the Blind Flying Panel are:

- a. Altimeter;
- b. Airspeed Indicator;
- c. Artificial Horizon;
- d. Vertical Speed Indicator;
- e. Turn and Slip Indicator; and
- f. Direction Indicator.

### How the Flight Instruments Work.

2.122 There are three main ways that flight instruments are operated:

- a. Air Pressure;
- b. Gyroscopes; and
- c. Compass.

### Air Pressure Operated Instruments.

2.123 The types of Air Pressure Operated Instruments are:

- a. Static – Normal Atmospheric pressure;
- b. Pitot – air press due to forward motion; and
- c. Pitot-Static – combination of the two.

### The Pitot Static System

2.124 Consists of a tube facing forward, so as to receive the full force of the impact air pressure. The tube also has small openings, which provide accurate measurement of static air pressure (not affected by forward airspeed). See diagram below.

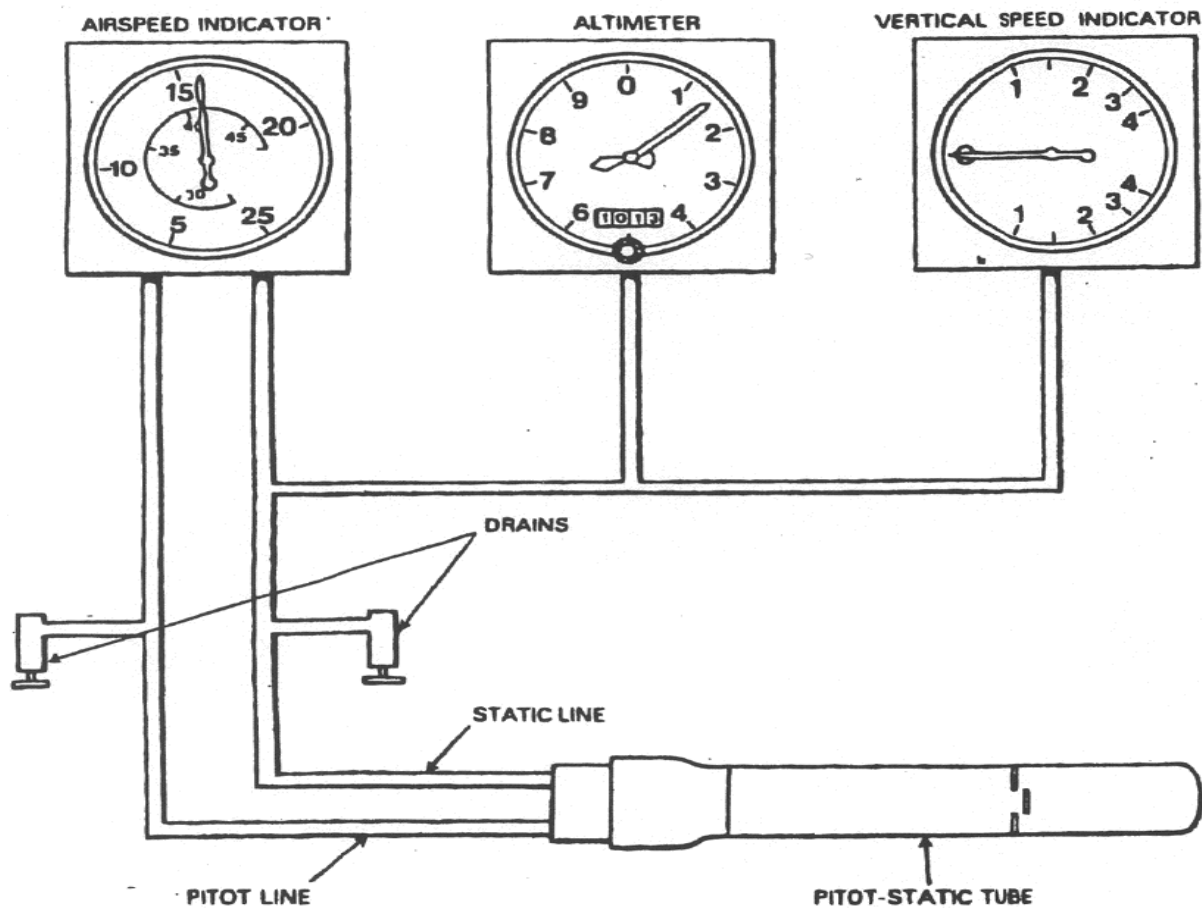

Fig 4.1 Basic pitot-static system

Fig 6.3 Pitot Static System



### Air Speed Indicator (ASI)

2.125 Indicates the airspeed by measuring the difference between pitot and static air pressures. This is then presented as an indicated airspeed.

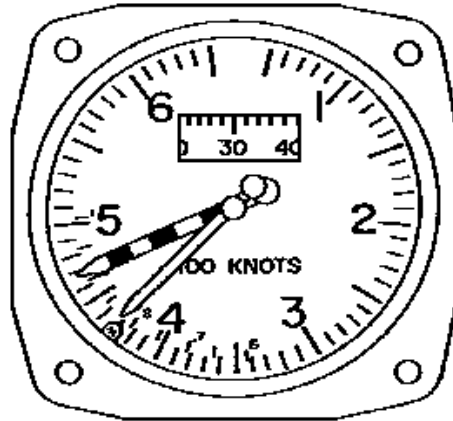

Fig 6-4 Airspeed Indicator

### Altimeter

2.126 Indicates altitude with reference to sea level. An adjusting knob is provided to set the altimeter for the ambient conditions of the day. The altimeter only uses static pressure.

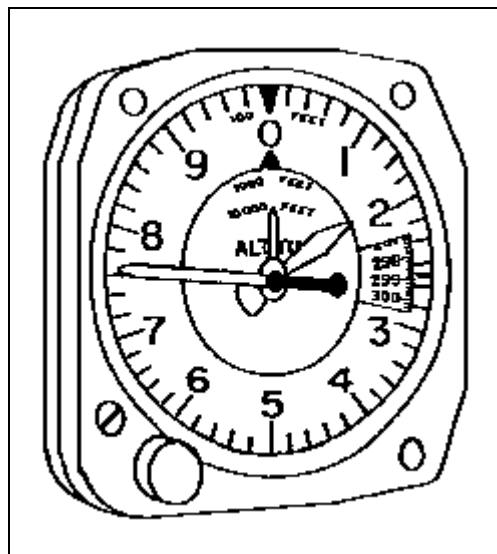

Fig 6-5 Altimeter

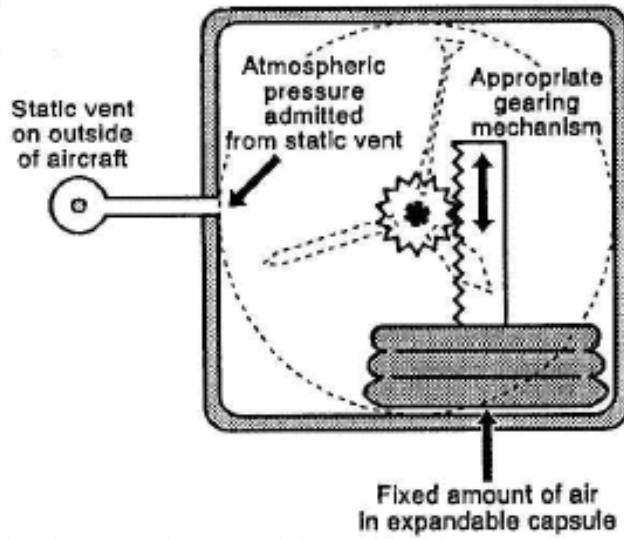

Fig 6-6 How an Altimeter Works

### Vertical Speed indicator (VSI)

2.127 Vertical speed indicators (VSI), use the changing air pressure outside the aircraft to provide an indication to the pilot of how fast the aircraft is climbing or descending.

2.128 VSI is measured in thousands of feet per minute.

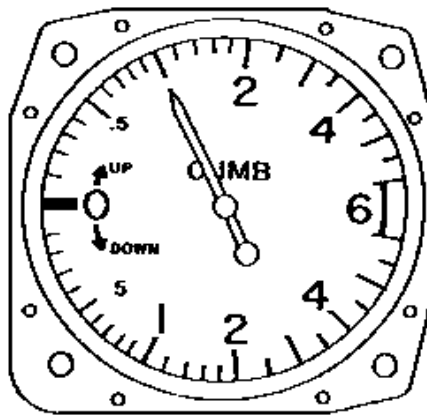

Fig 6-7 Vertical Speed Indicator



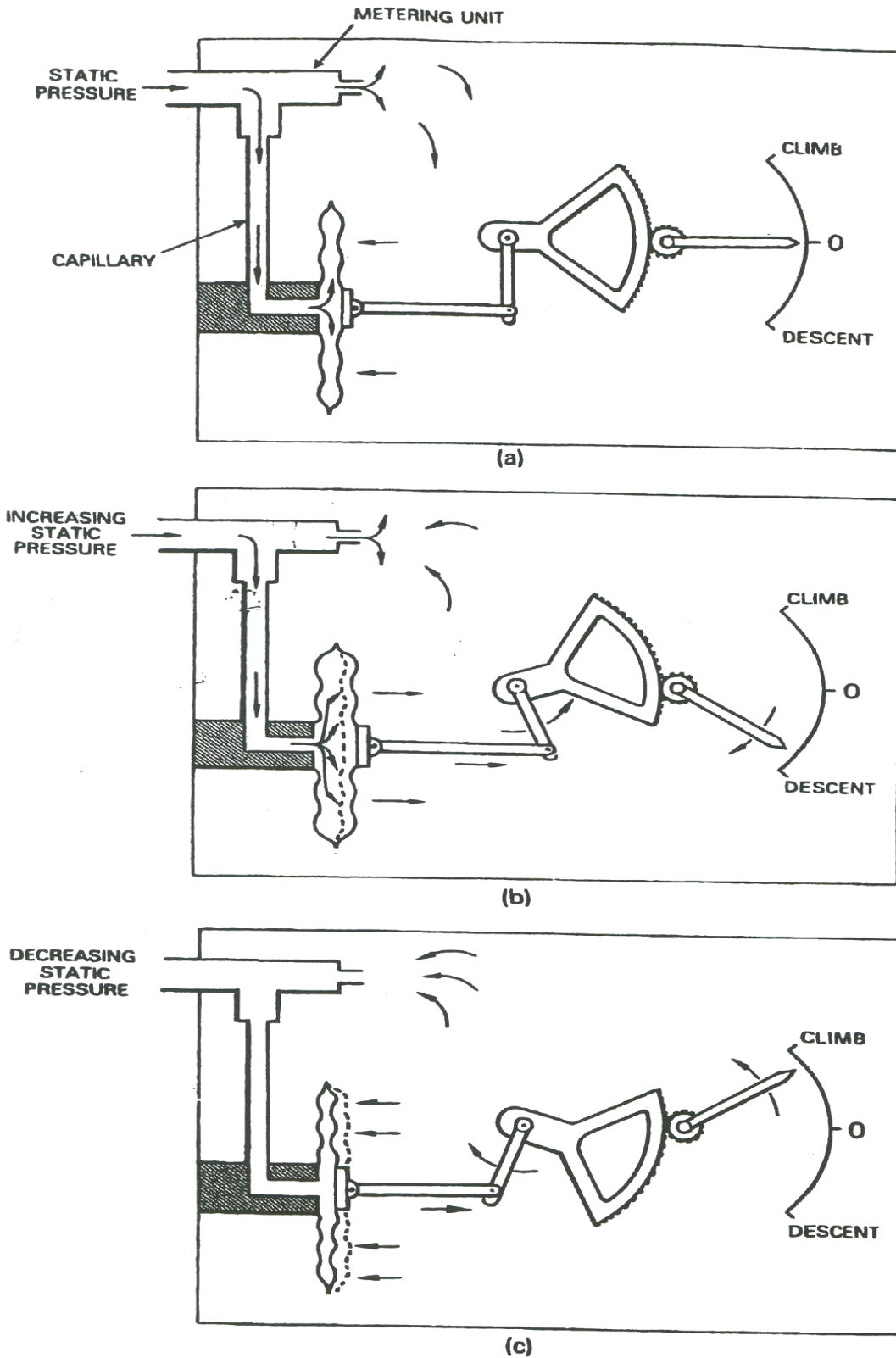

Fig 6-8 Principle of the Vertical Speed Indicator

## Gyroscopic Instruments

2.129 A gyroscope is a wheel or disc mounted to spin rapidly about and perpendicular to its axis. A spinning gyroscope resists any force, which tends to change the direction of the axis of spin.

2.130 This force can be measured and is indicated by the instrument.

### Turn and Slip Indicator

2.131 Coordinates and indicates the rate of turn. A pointer connected to a rate gyroscope indicates the rate of turn about the aircrafts vertical axis. Slip is indicated by the position of the ball in the curved tube

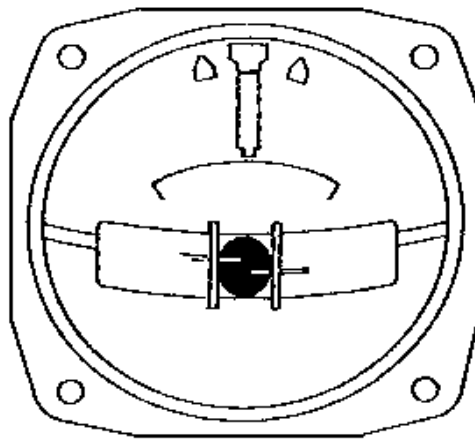

Fig 6-9 Turn and Slip Indicator

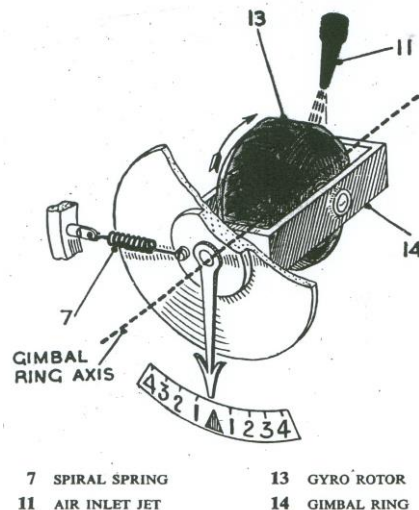

Fig 6-10 Turn Indicator Innards

## Artificial Horizon

2.132 This instrument indicates the movement of the aircraft in all three axis. These axis are:

- a. Roll;

- b. Pitch; and
- c. Yaw.

2.133 It is the pilots' master instrument and is powered by a gyroscope.

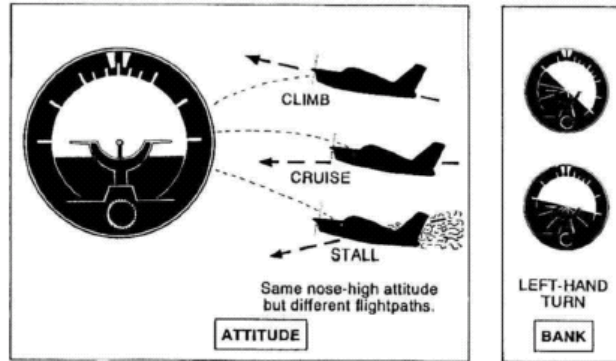

The attitude indicator shows pitch attitude and bank angle.

Fig 6-11 Artificial Horizon (Attitude Indicator)

### Directional Gyro

2.134 This instrument indicates the direction of the aircraft and is set from the aircraft magnetic compass. Unlike a magnetic compass it remains steady even during violent manoeuvres.

2.135 Sometimes they are a multipurpose instrument and include various nav aids within the one instrument.

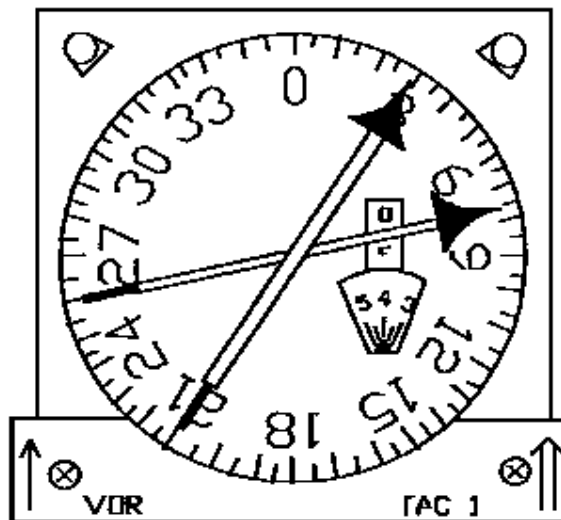

Fig 6-12 Directional Gyro

## Compass Instruments

2.136 In small aircraft the compass is normally used to determine aircraft heading. Where a directional gyro is used, the magnetic compass is occasionally used to reset the directional gyro to its correct magnetic orientation.

## Standby Compass

2.137 A standby compass is normally located on top of the glare shield in front of the pilot. The standby compass is a self-contained unit for use in emergencies. It requires no external electrical supplies and therefore will continue to provide heading information in the event of a total electrical failure.

## Engine Instruments

2.138 Engine Instruments consist of the following:

- a. Fuel contents;
- b. Fuel pressure;
- c. Oil pressure;
- d. Engine manifold pressure;
- e. Carb temp; and
- f. Exhaust/tailpipe temp.

## Quantity Gauges

2.139 Many aircraft system have reservoirs that contain fluids and gases. The aircrew and maintenance personnel need an indication of remaining fluids or gases in these systems.

2.140 Quantity indication systems consist of a measuring device and an indicator in the flight deck. Typical quantity gauges are:

- a. Fuel Quantity; and
- b. GOX or LOX Quantity.

2.141 Fuel Quantity is normally measured either as mass, in pounds or kilograms or Volume, in litres or gallons.

2.142 Oxygen quantity is normally measured in Litres for LOX (Liquid Oxygen) and PSI for GOX (Gaseous Oxygen).

## Engine Instruments

2.143 Engine instruments are provided to give the aircrew an indication of the performance of the power plant, enabling them to identify potential faults. There will usually be one indicator of each type for each engine

2.144 Engine instruments are replicated for each engine that an aircraft has, so in the case of Fig 5-13 (below) there are four of each gauge in the cockpit.

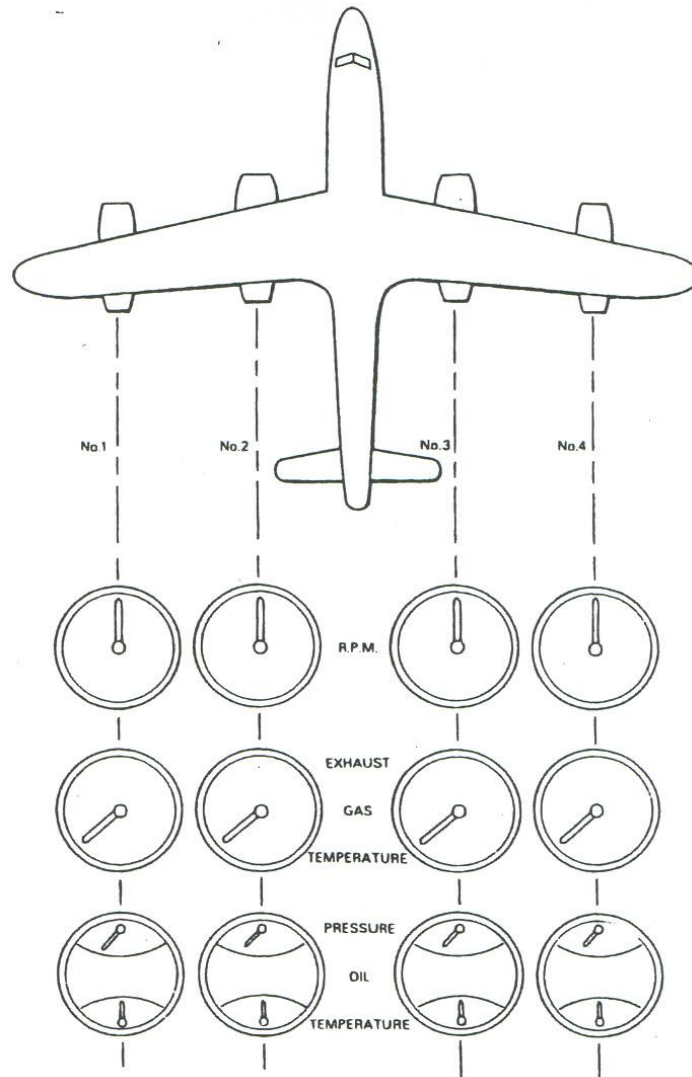

Fig 6-13 Multi Engine Instrument

### RPM Indicator

2.145 RPM indicators, also known as “Tacho indicators”, indicate engine speed. There are two basic types:

- a. RPM Gauge; and
- b. Percentage RPM Gauge.

2.146 The RPM gauge gives the revolutions of the engine crankshaft, used for piston aircraft.

2.147 The percentage RPM gauge gives the revolutions of the engine as a percentage of its maximum, e.g. "96% RPM", generally used for gas turbine engines.

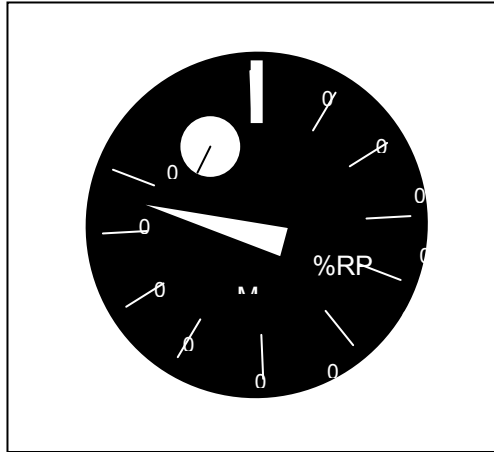

Fig 6-14 Percentage RPM Indicator

### Engine Temperature Indicators

2.148 An engine temperature indicator measures the temperature of the engine or the gases flowing through the engine. Generally the temperature is measured in degrees C.

2.149 Typical engine temperature indicators are:

- a. **Cylinder Head Temperature** – CHT used on piston engines;
- b. **Jet Pipe Temperature Indicator** – JPT used on a turbojet engine, typically for British aircraft;
- c. **Engine Gas Temperature Indicator** – EGT used on turbojet engines, typically for American aircraft; and
- d. **Turbine Inlet Temperature Indicator** - TIT used on turboprop engines.

2.150 Engine temperature indicators use thermocouples to sense heat.

### Engine Oil Pressure Indicator

2.151 Engine oil pressure indicator measures the pressure of oil supplied to the engine to provide warning of any loss of pressure before it becomes critical. Generally oil pressure is measured in PSI.

### Engine Oil Temperature Indicator

2.152 Engine temperature oil indicators measure the temperature of oil within the engine in degrees Celsius (°C).



Fig 6-15 C130 Hercules Cockpit

## POSITION AND PRESSURE INDICATORS

### Landing Gear Position Indicators

2.153 Landing gear position indicators are vital in that the pilot must know the position of the aircraft undercarriage at all times, especially on landing.

2.154 There are three undercarriage positions and they are indicated by:

- a. **Coloured lights:** One for each wheel:
  - (1) RED = Unsafe – landing gear is not locked (in transit).
  - (2) GREEN = Down and Locked, Normal condition for landing, taxiing and ground maintenance.
  - (3) No Light = Up and Locked, Undercarriage secured for flight
- b. **Dolls Eye:** A dolls eye indicator has a window for each wheel providing the following indications:



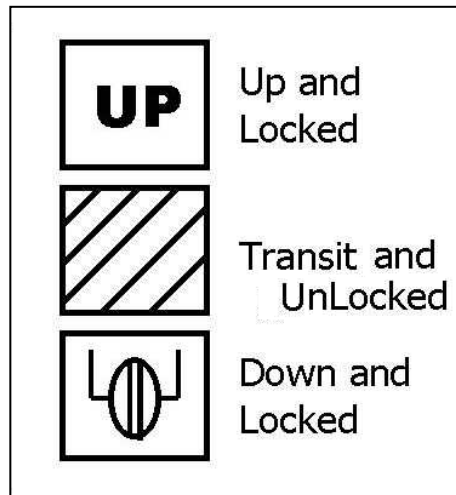

Fig 6-16 Gear Dolls Eye Indications

### Flap Position Indicators

2.155 Flap position indicators provide an indication of the position of the aircraft flaps to the pilot, who will not be able to see them from the cockpit.

### Pressure Indicators

2.156 Pressure Indicators are used to indicate the pressure for important systems throughout the aircraft. Some examples of systems are:

- a. Fuel Tank Air Pressure
- b. Hydraulic Pressure
- c. Brake Pressure
- d. Oil Pressure
- e. Engine Booster Pressure
- f. Pneumatic Pressure

2.157 The method of measuring will differ depending on whether the medium being.

### Combined displays

2.158 Modern aircraft often use combined displays to replicate all of the above primary flight instruments.

2.159 These displays are either a large coloured computer screen or a head up display, (HUD) and present the information in an easily understood manner.

2.160 HUDs were once only used in fighters, but are becoming the preferred standard display in tactical transport aircraft such as the C-130J and C-17.





Fig 6-17 Modern Cockpit Showing Combined and Multifunction Displays

### Navigation Instruments

- a. Clock
- b. Compass
- c. Radios
- d. VOR (VHF Omni Range)
- e. DME (Distance Measuring Equipment)
- f. Tacan
- g. NDB (Non Directional Beacon)

2.161 The type of navigation instruments fitted to an aircraft will vary between aircraft, however all aircraft will have at least a clock, compass and a radio fitted.

## SECTION 8 - Airfield Circuits

### The Circuit

2.162 The basic airfield circuit can be run as either a left hand or right hand circuit. It is made up of various components as follows:

- a. Upwind leg;
- b. Crosswind leg;
- c. Downwind leg;
- d. Base leg; and
- e. Final approach.

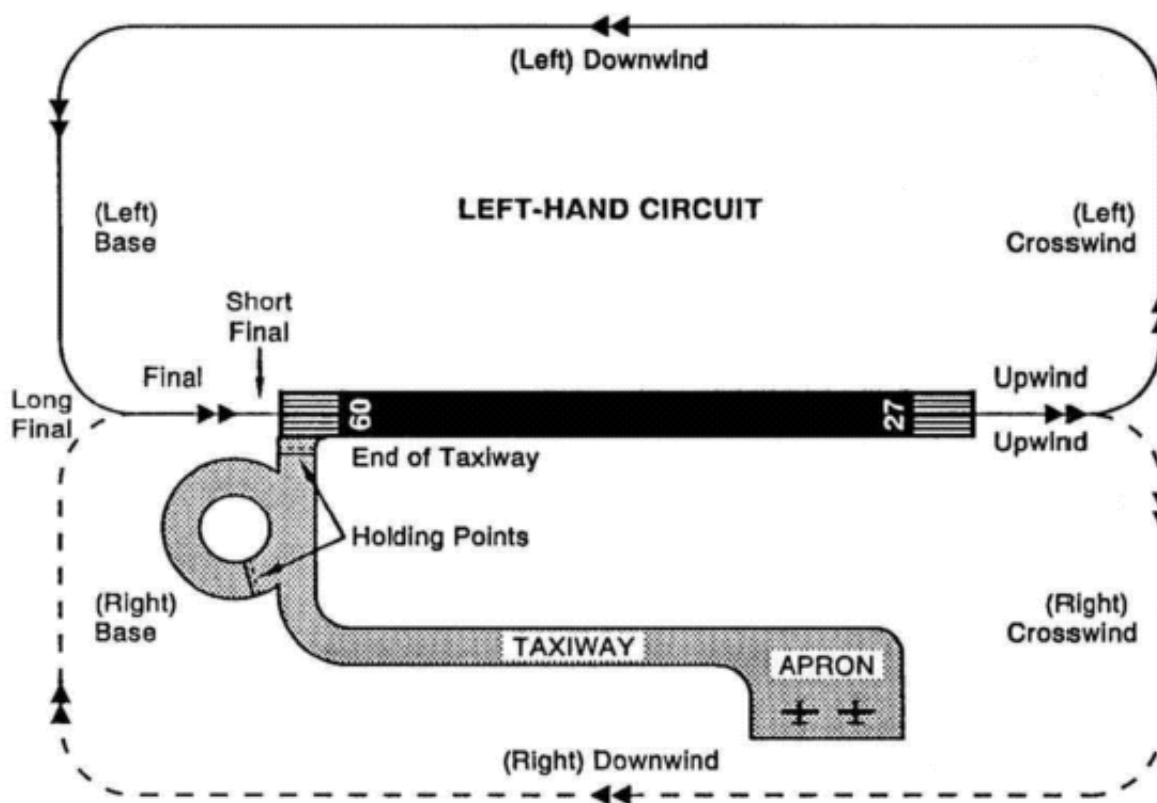

Fig 7-1 The Circuit

### Takeoff - Upwind

2.163 Takeoff is made into wind. An aircraft climbs straight ahead to a height of 500' before commencing a left turn onto Crosswind leg. Generally circuits are flown to the left, as pilots in command are seated in the left hand seat, and gives better vision. Some airports have dual runways. An example being one that might have runways 21L(left) or 21R(right) and aircraft are required to turn left or right at 500' respectively after taking off.

## Crosswind

2.164 The aircraft continues to climb to circuit height, 1,000', and level out. Should the crosswind be strong, the pilot should point the nose slightly into wind to save from being blown off track.

## Downwind

2.165 Downwind is flown at circuit height parallel to the runway. During this leg, the pilot makes a radio call, which tells the air traffic controller the aircraft's position and intentions. The pilots will also do their downwind landing checks, to ensure the aircraft is ready to land.

## Base Leg

2.166 The pilot turns onto "Base" when they are at a point relative to the aircraft's performance, the aircraft is placed in a descent, power reduced and flaps used to control the aircraft's attitude. Generally, aircraft will descend to between 500' and 700' before turning onto "final".

## Final Leg

2.167 During this leg, the pilot adjusts the flaps and power to ensure the aircraft does not under/over shoot the runway. Final leg completes the circuit once the aircraft has landed.

## Use of Circuit

2.168 The circuit has been designed to assist the smooth flow of traffic around an airfield. It should be seen that if pilots were left to their own resources, accidents would frequently occur, so a standard set of rules allows for good separation and entry into a circuit area.

## Dead Side

2.169 A circuit has a "dead" side. That is the airspace on the opposite side of the runway in use.

2.170 Aircraft arriving at an airfield, which is unmanned, must overfly the airport at 1,500' above airfield level, check for wind direction and then fly to the dead side and then descend to the required height to enter the circuit.

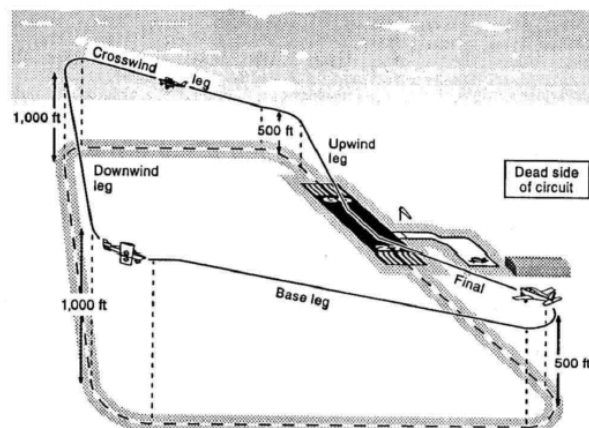

## CHAPTER 3 – Basic Aviation

### SECTION 1 - Advanced Flight Aviation Studies Objectives

#### Advanced Flight 2.1

- a. Proficiency Year Revision;
- b. Time:
  - (1) One 40 min theory lesson.
- c. Scope / Range:
  - (1) Aviation careers.
  - (2) Airfield safety.
  - (3) Aircraft propulsion.
  - (4) Cockpit layout.
  - (5) Airfield circuits.
- d. Reference(s):
  - (1) NZCF 142.

#### Advanced Flight 2.2

- a. Clouds and precipitation;
- b. Objective(s):
  - (1) Describe how clouds and precipitation are formed.
  - (2) Identify cloud types.
- c. Time:
  - (1) Two 40 min theory lessons.
- d. Scope / Range:
  - (1) The atmosphere.
  - (2) Cloud types.
  - (3) Fog and mist.
  - (4) Precipitation.
- e. Reference(s):

- (1) NZCF 142.
- (2) Weather to fly.

### **Advanced Flight 2.3**

- a. The Weather Map;
- b. Objective(s):
  - (1) Explain the meaning of the symbols on a weather map.
- c. Time:
  - (1) Two 40 min theory lessons.
- d. Scope / Range:
  - (1) Symbols on the weather map.
  - (2) Flying hazards.
  - (3) TAF's and METAR's.
  - (4) Reading the weather (Forecasts).
- e. Reference(s):
  - (1) NZCF 142.
  - (2) Weather to fly.

### **Advanced Flight 2.4**

- a. Basic Helicopter Theory;
- b. Objective(s):
  - (1) Describe the theory of basic helicopter flight.
  - (2) State the function of a helicopters' flight controls.
- c. Time:
  - (1) One 40 min theory lesson.
- d. Scope / Range:
  - (1) Helicopter configurations.
  - (2) Helicopter controls.
- e. Reference(s):

- (1) NZCF 142.
- (2) Outside Instructor.
- (3) Aviation Theory Centre Helicopter Manual.

### **Advanced Flight 2.5**

- a. Aviation Navigation One;
- b. Objective(s):
  - (1) Explain the symbols and scales on aerial navigation maps.
- c. Time:
  - (1) Two 40 min theory lesson.
- d. Scope / Range:
  - (1) Map and charts.
  - (2) Scales and symbols.
- e. Reference(s):
  - (1) NZCF 142.
  - (2) NZCF158, Chap 2 Page 81.
  - (3) ATC NAV Vol 2.
  - (4) Local Aero Club.

### **Advanced Flight 2.6**

- a. Aviation Navigation Two (Elective);
- b. Objective(s):
  - (1) Produce a basic flight plan for a flight between a minimum of three points.
- c. Time:
  - (1) Six 40 min theory lessons.
- d. Scope / Range:
  - (1) Basic navigation terminology.
  - (2) Flight planning.
  - (3) The navigation computer.

- (4) Time, Speed, Distance.
- (5) Flight logs.
- e. Reference(s):
  - (1) NZCF 142.
  - (2) NZCF158, Chap 2 Page 81.
  - (3) ATC NAV Vol 2.
  - (4) Local Aero club, Fenwick.

### **Advanced Flight 2.7**

- a. Aviation radio procedures;
- b. Objective(s):
  - (1) Demonstrate correct use of aviation radio procedures.
- c. Time:
  - (1) Three 40 min theory lessons.
- d. Scope / Range:
  - (1) Frequencies.
  - (2) Radio procedure- phonetics words & figures.
  - (3) Communications.
  - (4) Aircraft call signs.
  - (5) Emergency calls.
- e. Reference(s):
  - (1) NZCF 142.
  - (2) NZCF 158 ATC Radio FRT0.



## SECTION 2 - Clouds and Precipitation

### The Weather

3.1 It is changeable and difficult to predict. We can get some understanding by studying weather maps and pressure, and by observing the clouds and the winds.

3.2 The aviator is at the mercy of the weather at all times. It is only with a sound knowledge of meteorology that they will be in the position to understand what they are seeing and use this knowledge to make their decisions.

### The Atmosphere

3.3 The atmosphere is an ocean of air surrounding the earth to a height of 200 km. Although it is invisible, air behaves like a fluid, which means that it flows like a fluid. When a ship passes through water we can see the bow wave and the wash with all its eddies and whirlpools.

3.4 A similar but more dramatic effect occurs when an aircraft moves through the air. Because air is invisible we don't normally see the result. If we introduce smoke into a wind tunnel during testing we can see the effect that an aircraft has on the air around it.

3.5 The atmosphere is effectively around 100 kms thick in total. It has a total weight of around 5 million billion tonnes!



Fig 1-1 Airflow Affecting the Lake Surface

3.6 Weather occurs in the troposphere - the layer of air about 10-15 kms thick above the earth.

3.7 The temperature does not drop continuously as you rise. Some higher layers in the atmosphere actually heat up as you move up through them. We are only interested in



the lower layer of the atmosphere and in this area; the temperature will decrease by about 70oC as we rise.

3.8 The atmosphere spins with the earth and any variations to speed are relative to this. Imagine if the atmosphere turned independently of the ground - the wind at the equator would be over 1600 km/hr

3.9 Nitrogen and Oxygen make up most of the atmosphere. A number of other gases occur in the atmosphere but their levels are too low to have significant effects.

3.10 The gases are generally well mixed due to winds; however the amount of water held in the atmosphere varies considerable over time and by location.

3.11 The level varies from about 0% to 4% as water is constantly evaporating from the ocean into the atmosphere and then falling out again as rain or snow.

### **Atmospheric Density**

3.12 The density of air is how much you can pack into a defined space. At sea level, the density of air is around 1.2kg per cubic metre. That means the total weight of air molecules that fit into a 1 cubic metre box would weigh 1.2kgs at 20oC.

3.13 At the top of Mount Everest the molecules are spread further apart, and only 0.4kgs would be found in 1 cubic metre. The result of this is that at the top of Mount Everest, each lungful of air will give the body only one-third as much oxygen as at sea level.

3.14 The density of air will change if the temperature of the air changes. The density will decrease if the temperature increases as the air molecules will be pushed further apart.

### **Air Pressure**

3.15 Air pressure at sea level is the weight of a column of air pushing down on the earth and is measured with a barometer; it is commonly measured in hPa or kPa although other measurements may be seen:

- a. 1 Atmosphere =
  - (1) 29.92 inches of Hg.
  - (2) 101.325 kPa.
  - (3) 1013.25 mb or hPa.
  - (4) 14.7 psi.
  - (5) 33 feet of water.

3.16 Like density, the air pressure is less at higher altitudes, as the amount of air above that spot is less. The decrease of air pressure with increasing altitude has a key role to play in creating weather as follows:

- a. At sea level – 1012hPa;
- b. At 2 kms – 800 hPa;
- c. At 24 kms – 50 hPa; and
- d. At 26 kms – 30 hPa.

3.17 Air will always try to flow from an area of higher pressure to one of lower pressure until the pressures are equal. The greater the difference in pressure (the pressure gradient), the greater the force (wind) will be.

3.18 Pressure and temperature are directly related. Changing the pressure in a system alters the temperature. This works both ways. Changing the temperature will alter the pressure.

3.19 As air rises (reducing pressure) it expands, cooling the air at a rate of around 2oC for each 1000 feet it rises.

3.20 When you take the top off the soft drink bottle, the pressure in the bottle drops very, very rapidly. As the pressure is released, the temperature drops dramatically - often low enough for the water vapour in the neck of the bottle to condense into a foggy mass. If air is compressed it will heat up. This helps to explain why air at lower altitudes is warmer than air at higher altitudes.

3.21 This heating by compression also has a strong influence on our weather.

### **Water in the Atmosphere**

3.22 The atmosphere above the earth is the factory in which our weather is made. Water is the main raw material for this factory. The sun is the engine that makes it work. Water can exist in three states, solid (snow or ice), liquid (water) and gas (water vapour). It requires energy to be added or removed to change it between each of these phases or states.

3.23 It is waters ability to exist in these three states - often at the same time - that gives us our weather and indeed makes life possible on the earth. Water is only visible in the atmosphere when it is in its solid or liquid form. Humidity is the term used to describe the amount of water vapour in the atmosphere. The temperature of the air controls the amount of water vapour that can be present in the air at any given time. This is a maximum of 1 – 4% depending on the temperature of the air

3.24 If the air is holding the maximum amount of water vapour for its temperature, it is said to be 'saturated'.

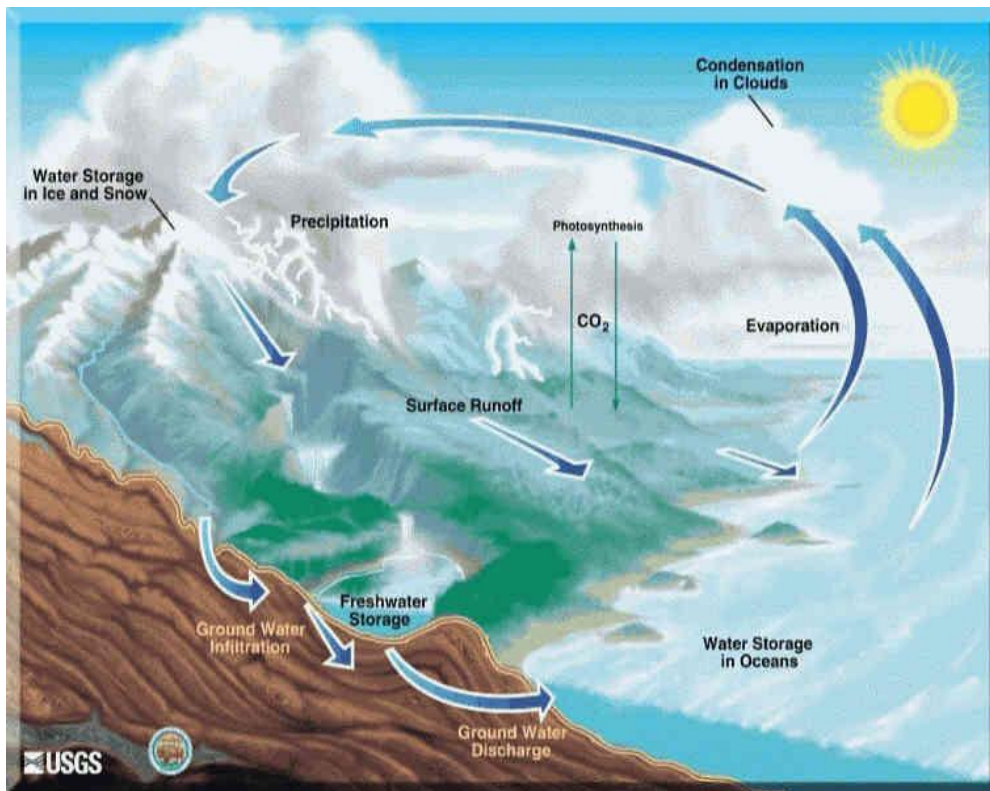

Fig 1-2 The Water Cycle

## Clouds

3.25 If air rises high enough in the sky, expanding and cooling, it will eventually cool enough to reach its saturation point.

3.26 If the air continues to rise, and hence cool further, some of the water vapour will condense to form clouds.

3.27 Cloud droplets can stay in the air because they are extremely light and hence fall slower than the air rising around them. Over time these droplets will collect together and get larger.

## Naming of Clouds

3.28 The naming of clouds is quite simple. Because clouds change over time and as the conditions change in which they exist, we really have a continuum of cloud structures rather than absolute cloud types. More than 100 cloud types have been identified and classified.

3.29 Because of this, many cloud names become a combination of the basic names given e.g. altostratus for high layered cloud.

3.30 In many cases, we do not have only one type of cloud present and the sky may be a mix of many types as the conditions are changing. This helps us to understand what is happening with the weather, and it is more important to understand the overall result than to become too hung up with individual clouds and their names.

## Cloud Names

- 3.31 The following will help you understand the different cloud names:
- a. **Cirrus (cirro)** – ‘Curl of hair’, fine or wispy;
  - b. **Stratus (strato)** – Spread out or layered;
  - c. **Alto** – High;
  - d. **Cumulus (cumulo)** – Piled or puffy; and
  - e. **Nimbus (nimbo)** – Rain or thunder.

## Cloud Types

- 3.32 The following are the cloud types and at what altitude they are normally found:
- a. High Clouds – 6,000 to 12,000 metres:
    - (1) Cirrus, Cirrocumulus, Cirrostratus
  - b. Mid -Range Clouds – 2,500 to 6,000 metres:
    - (1) Altocumulus, Alto stratus
  - c. Low Clouds – below 2,500 metres:
    - (1) Nimbostratus, Stratocumulus, Stratus
  - d. Wide Range Clouds:
    - (1) Cumulus (base to top: 2,500 to 12,000 metres)
    - (2) Cumulonimbus (base to top: 3,000 to 18,000 metres)

## Cirrus Clouds

3.33 The highest of clouds at 6 to 12,000 metres. The delicate fibres of these clouds are usually white filaments composed of tiny ice crystals, sometimes with a silky sheen. These clouds are the first to appear with an approaching warm front. They do not lead to rain themselves, but often indicate a front several hundred kilometres distant, whose fringe winds may create the conditions in which cirrus clouds form. Cirrus clouds often have upturned ‘hooks’ at the downwind end. They are also called ‘mares’ tails’ and as the old saying goes, when the mares’ tail goes up, something is about to come down....



Fig 1-3 Cirrus Clouds

### **Cirrocumulus Clouds**

3.34 Also found at 6-12000 metres, these clouds are a thin sheet of white. Cirrocumulus and are composed of very small grains or ripples, sometimes merged and sometimes separate, but always more or less regularly arranged. A precursor of a warm front, it usually thickens into cirrostratus over a period of time. This is the first stage of thickening of cloud as bad weather approaches on the down side of a high pressure cell.



Fig 1-4 Cirrocumulus

### **Alto cumulus Clouds**

3.35 The first of the mid-range clouds forming between 2,500 metres and 6,000 metres, alto cumulus is composed of water droplets rather than the ice crystals of the cirrus clouds. This cloud is a canopy of white or grey flakes, rounded masses and rolls. This cloud is sometimes a sign of rain, especially when some of the masses rise higher than their



neighbours. This effect sometimes leads to thunderstorms as it is associated with the lifting of a large air mass and instability in the middle levels of the atmosphere. These clouds are also known as the mackerel sky. They are similar to cirrocumulus but are at a much lower altitudes. They are likely to indicate approaching rain.



Fig 1-5 Altocumulus

### Stratocumulus Clouds

3.36 Stratocumulus is the most common cloud type and often forms in layers hundreds of kilometres across. It usually has a ragged upper surface while the base is relatively flat. It is often seen with irregular folds and layers interspersed with dark sheets or patches and are likely to form in the wake of a cold front which is overrunning an area. Stratocumulus is not usually a precipitation cloud, but occasionally may produce a light sprinkling of snow.



Fig 1-6 Stratocumulus

### Cumulonimbus Clouds

3.37 These also build over a great height and are common over summer landscapes and tropical seas. The tallest cumulonimbus clouds (called Cumulonimbus Incus or

Capillatus) reach high into the cold upper air where the strong winds flatten their tops to form the typical anvil head with trailing wisps of cirrus. These clouds almost invariably bring thunderstorms and heavy rain, occasionally producing hail.

3.38 A relatively large cumulonimbus cloud system exists that is called a Super cell. These produce most of the damage associated with severe thunderstorms by producing large hail, flash floods, severe wind gusts, wall clouds and tornadoes and have a relatively long life span - typically 2 hours or more.



Fig 1-7 Cumulonimbus

### Frontal Clouds and Warning Signs

3.39 When a warm front approaches, the warm air readily rises over the cold, and the first we see of this is ice particles appearing as cirrus clouds high in the atmosphere. These are gradually followed by altostratus and nimbostratus clouds, prior to the arrival of the front. In each case the first clouds are high and thin, with each succeeding cloud type appearing lower, thicker, darker and denser. This combination usually gives rain just prior to the front passing and air temperatures that rise as the rain falls. The passing of the front is usually followed by layers of stratus cloud forming in the warm air of the low that follows. An approaching cold front is much more sudden, with air being forced abruptly up into the atmosphere just before the front. This causes strong rains and often violent thunderstorms. There is often a sudden temperature drop as the cold front passes over and showers continue from cumulus clouds following the front.



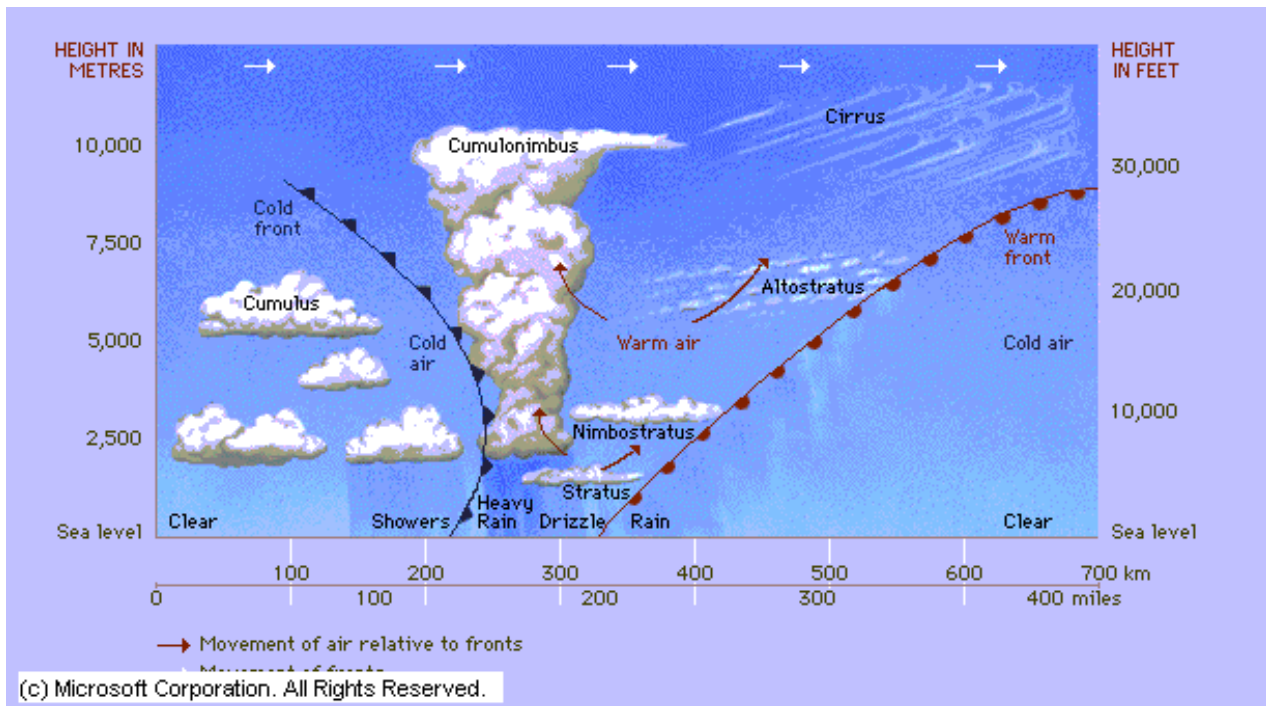

Fig 1-8 Warm and Cold Fronts

### Fog and Mist

3.40 Fog is simply cloud resting on the Earth's surface. It forms when humid air next to the ground is cooled enough to reach its saturation point, so that the water vapour then starts to condense into liquid droplets. This most commonly occurs on a clear night with light wind, where the ground cools as heat radiates away cooling the air from below. **What is different from dew formation?** If the ground is cold enough then water will condense from the fog to form dew first and then fog some hours later. If the ground is below freezing before the water vapour starts to condense then frost will form followed by fog several hours later.



Fig 1-9 Fog

3.41 With no wind, the fog will often be only a metre or so thick, while with very light winds it may mix and form a layer 30 metres thick. Because the difference in wind velocity in these two cases is very small, it is exceptionally difficult to measure. If the wind is too strong, excessive mixing will occur and the cloud will not form at the ground at all. Fog can also form when warm humid air blows over a cool surface or a cold ocean current meets a warm one, (sea fog). Fogs clear by solar heating, dispersal by wind or by settling to the ground.

### **Mist**

3.42 The main difference between fog and mist is the degree of visibility. In mist visibility is generally greater than 1000 metres while in fog it is less. Fogs can also form when cold air moves over relatively warm water. This is why fogs occur over swampy ground - air cooled at night over nearby land flowing downhill (the katabatic wind) to the lowest ground where swamps are often located. Swamp water then evaporates into the cold air which is warmed by the water surface. The warming causes the air to rise mixing with the cold air above, cooling it to its saturation point and creating condensation or fog.



Fig 1-10 Mist

## PRECIPITATION

### Warm Rain Process

3.43 If air rises high enough in the sky, expanding and cooling, it will eventually cool enough to reach its saturation point. If the air continues to rise, and hence cool further, some of the water vapour will condense to form clouds.

3.44 Cloud droplets can stay in the air because they are extremely light and hence fall slower than the air rising around them. Over time these droplets will collect together and get larger. The larger a droplet becomes, the faster it falls, until the rising air is insufficient to keep it airborne.

3.45 As the larger cloud droplets fall, they capture smaller droplets, thereby growing even larger and falling faster. Eventually they may grow large enough to fall out of the cloud towards the ground.

3.46 This process is called the warm rain process as no ice is involved in the process. The warm rain process is not common in New Zealand - most of our rain comes from the ice process. Rainfall is generally measured in mm over some defined period.



Fig 1-11 Warm Rain Process

### Rain - Ice Process

3.47 Most of the rain in New Zealand commences with the formation of ice crystals in the upper atmosphere. Ice crystals are more efficient at capturing water vapour from the air than water droplets.



Fig 1-12 Ice Process

3.48 Once ice crystals form in the atmosphere, water vapour deposits on the surface so fast that the air's humidity falls below 100%. This causes the water droplets to evaporate into the air providing more water vapour to deposit onto the ice crystals. This starts a runaway process until the ice crystals get too big to remain in the cloud and they fall faster,

causing them to bang into more water droplets in its path, which freeze onto the surface making it bigger.

3.49 Eventually the ice crystal falls into warmer air near the earths surface where it melts into rain before falling to the ground. Note that showers that come from cauliflower shaped cumulus clouds normally only last 10 minutes or so. Rain coming from nimbostratus can last for some time.

## SECTION 3 - The Weather Map

### Weather Maps

3.50 The weather maps we use most often are 'prognosis' or forecast maps indicating expected weather at sea level. Analysis maps are also used to explain the weather that we have just experienced.

3.51 The weather maps are constructed from satellite photos taken in visible, IR and other light frequencies and combined with observations from ground stations and other measurement systems.

3.52 A series of conventional signs are used to indicate different activities on the map. Most weather maps and all satellite images are stamped using the UTC time. This is the Coordinated Universal Time and is the same as GMT.

3.53 Weather forecasts are generally based around conditions at sea level, and not at higher levels where the airflow may be doing something entirely different. They are also very general and do not take into account local features that can change the conditions in an area.

3.54 Mountain forecasts are often issued for specific mountain areas. These try to take in to account such things as the altitude, local winds, effects of neighbouring air masses, convergence, wind pressure build up and rain caused by wind flowing over the hills etc.

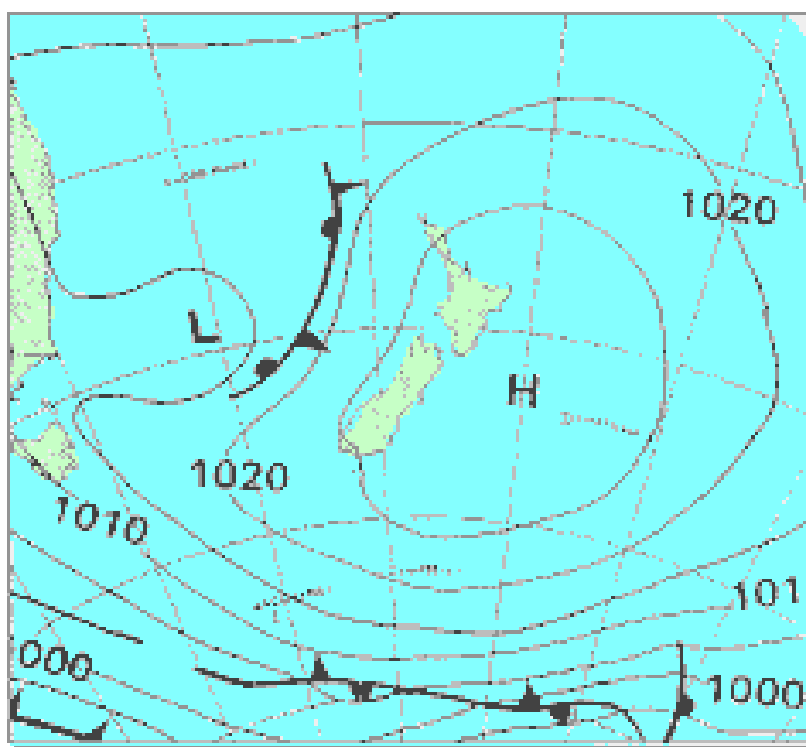

### Isobars

3.55 These are the numbered lines on the weather map that join places where the air pressure is equal. The numbers are measured in hPa and drawn at regular intervals of 4hPa. Around New Zealand we normally have weather in the range 1040 to 960hPa.

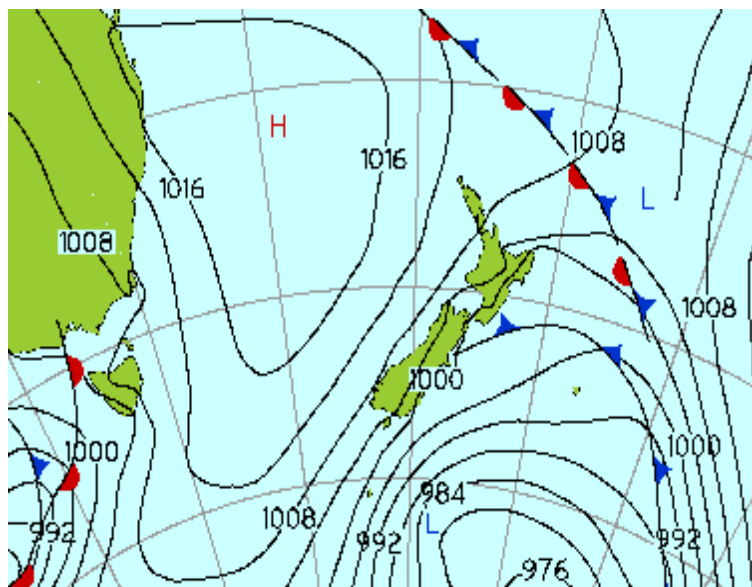

## Wind

3.56 Air moves across the Earth's surface from high to low pressure, but is deflected by the Earth's rotation. The result of this is that the wind blows almost parallel to the isobars - crossing them at a small angle. This angle is around 15° over the sea and 30° over the land due to the higher friction involved.

3.57 In the southern hemisphere, the wind blows anticlockwise around a high and clockwise around a low.

3.58 In general, the closer the isobar lines are together the stronger the wind will be. Hence the wind will be stronger at point B than at point A. The effect is however dependant on Latitude. Winds are stronger for identical spacing near the equator than further south. Wind at curved isobars around a high is stronger than the spacing may suggest and lower when curved tightly around a low.

3.59 When warm air flows over a cold sea, the lower air tends to cool down, which increases its density and slows it down. This means the surface wind can be up to 40km/hr less than the speed 100m in the air!

## Terrain Effects

3.60 One terrain effect that shows up on the New Zealand weather map is that the Southern Alps distort isobars crossing them. On the weather map in this picture, the Southern Alps buckle the isobars coming in from the Tasman Sea, with a build-up of pressure on the windward side and a counterbalancing drop of pressure down-wind from the mountains. Because of this distortion, *avoid* trying to use isobars over mountains to



work out wind direction. Also, in general, *avoid* using isobars to work out wind flow over

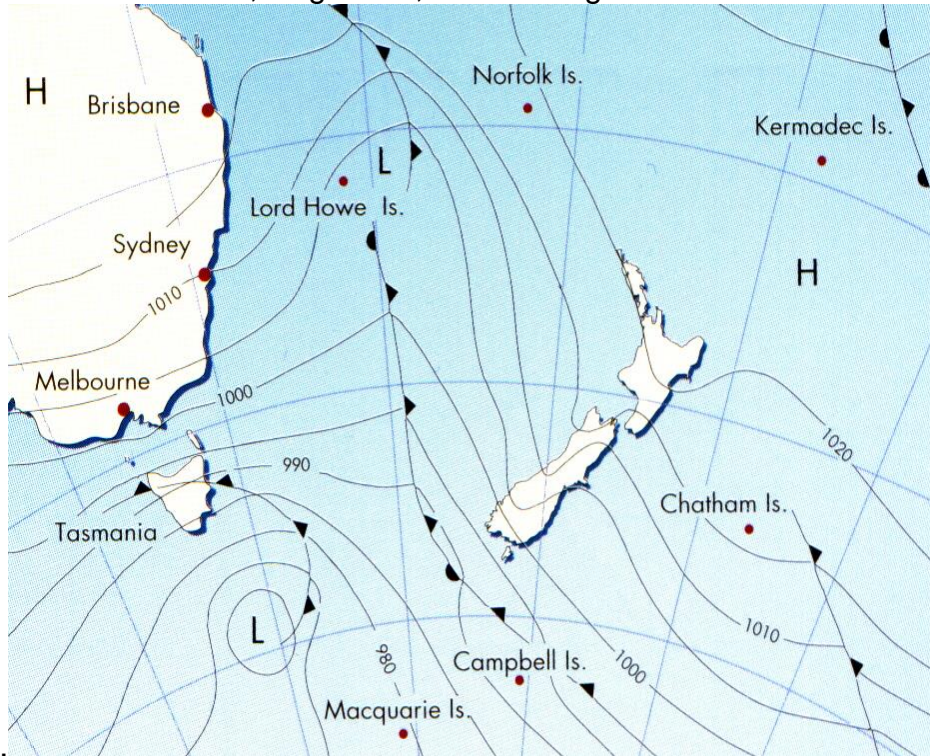

high ground.

### Ridges

3.61 An area of high pressure extending away from the centre of a high is called a ridge. This is not usually marked on the weather map, but gives very similar weather to a high.

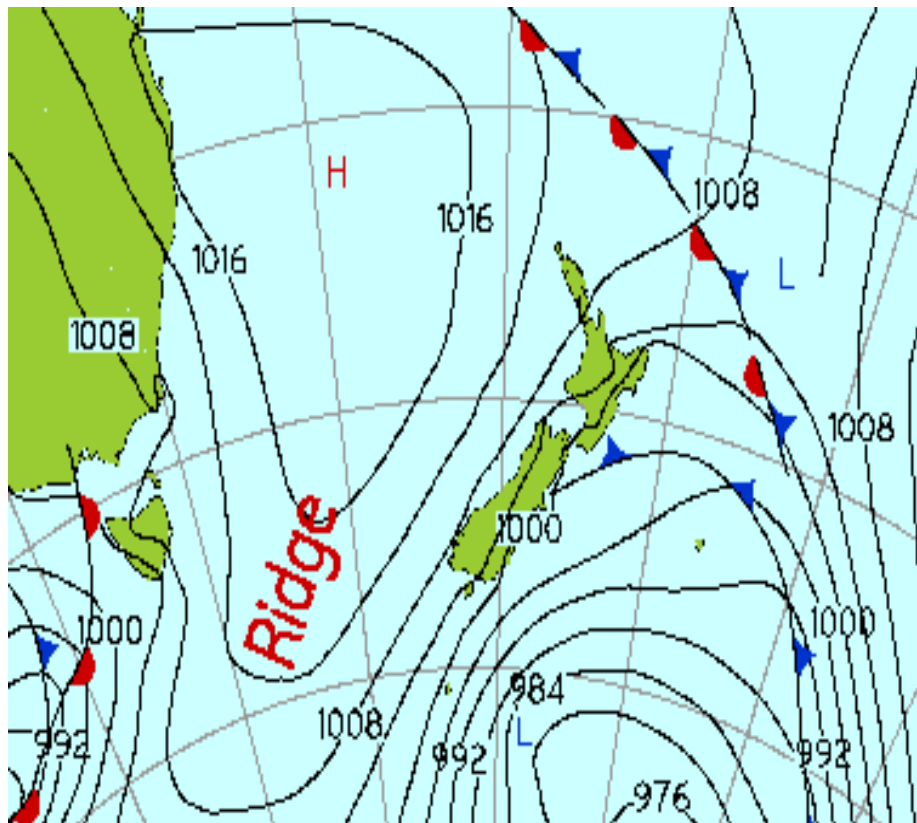

## Troughs

3.62 A trough is an area of low pressure extending away from the centre of a low. Fronts often develop in troughs and so they may contain thunderstorms or showers.

3.63 Troughs are usually marked on the weather map with a dashed line with no other symbols attached.

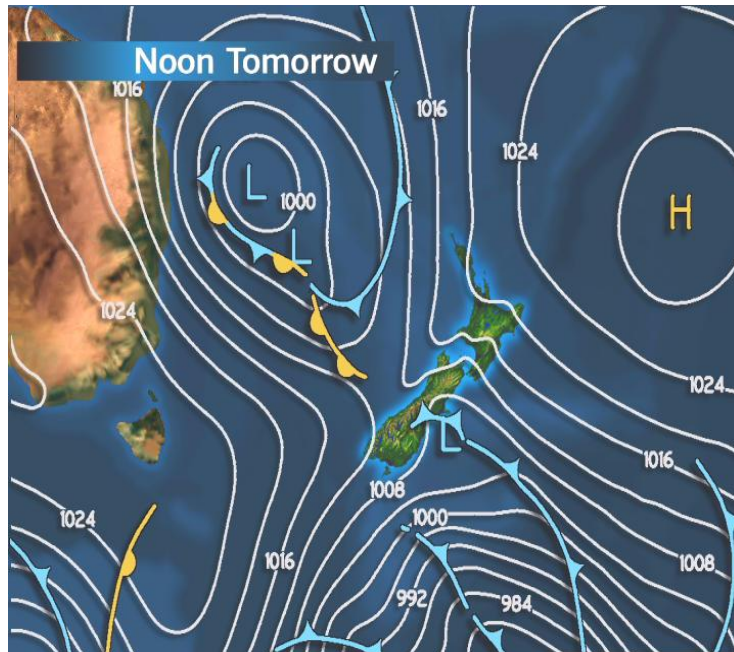

## Fronts

3.64 Cutting across the isobar lines, fronts are marked by lines with black triangles or half moons on them. Fronts are places where upward movement of air occurs, and have broad bands of cloud containing narrower bands of rain.

3.65 Fronts are the boundaries between air of different temperatures and origin, eg warm air from the tropics meeting cold air from the poles.

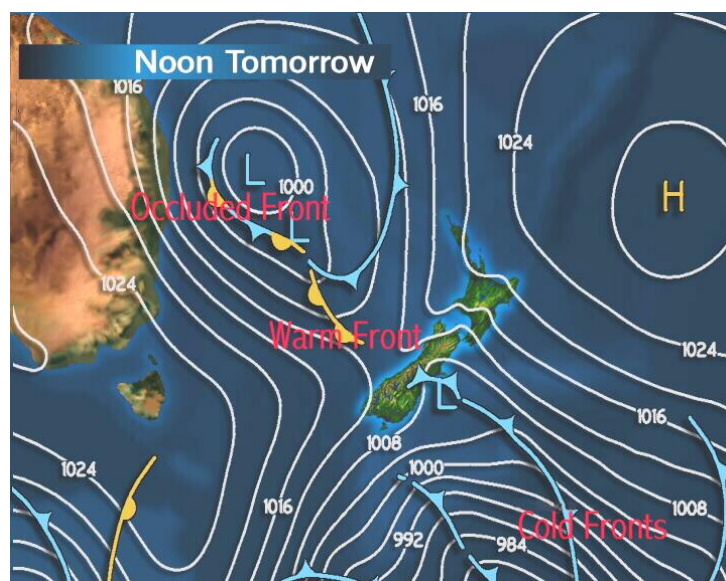

3.66 Cold fronts are marked with black/blue triangles - cold air advancing to replace warm air. Warm fronts are marked with black/yellow half moons - warm air advancing to replace cold air.

3.67 An occluded front has black triangles and half moons on the same side of the line. The symbols are placed on the side of the line indicating the direction of movement. If the symbols are on opposite sides of the line, we have a stationery front, while a dashed line shows the front is weak.

3.68 A stationary front will stick around for some time and bring lots of heavy rain. If the air masses are big, they can last for 5 days or more and bring 50-200 mm rain.

## SECTION 4 - Flying Hazards

### Thunderstorms

3.69 A large thunderstorm presents a variety hazards to an aircraft; they are best avoided by quite a wide margin as several of the hazards exist not only inside the cloud, but also within its general vicinity. The hazards, in no particular order, are:

- a. **Icing.** Very severe icing is often present
- b. **Precipitation.** Many different forms of presentation come from thundercloud, but the most common is hail. Some hailstones can be large enough to damage airframes.
- c. **Turbulence.** The air inside a thunder cloud can be in vertical motion (up or down) at speeds in excess of 50 knots, and the change from up, to down, and back again can be very sudden. This leads to very severe turbulence, which, in the worst cases, has been known to destroy aircraft.
- d. **Lightning and Thunder.** The most obvious effect of being hit by lightning is the surprise or fear which it creates. In fact, lightning does much less damage to an aircraft than you might expect because it tends to travel around the skin of the aircraft and come out the other side. It can puncture the skin surface of the aircraft, but the most significant effect is normally on navigation systems, compasses and radios. Additionally a lightning strike can temporarily blind the aircrew, which can be quite upsetting in the landing stage.
- e. **Landing Hazards.** All of the above hazards exist underneath the base of a thunderstorm – the most significant being the risk of a severe downdraught just as the aircraft is over the runway threshold and has little room or ability, to manoeuvre. On the ground a flooded runway can cause problems on the landing or take off run. It is also very dangerous to refuel an aircraft during a thunderstorm.

3.70 Most modern aircraft carry a radar which is specifically designed for detecting thunderstorms and very turbulent air within clouds. This system gives the aircrew the ability to avoid thunderstorms and all of the hazards which they present.



## SECTION 5 - TAF's and METAR's

3.71 The weather forecaster uses many charts and symbols to convey the details of the weather over the whole country. For an aviator, who has to receive the information by radio, the weather situation has to be coded as word pictures are too vague. The code is standardised to avoid language barriers, and apart from some variation in the units involved, is common to virtually every country. The code is used in two formats; one is the **TAF** (Terminal Aerodrome Forecast) and the other is the **METAR** (Meteorological Actual Report). In simple terms, one records a forecast and the other reports the actual conditions. The full codes are complex, but there are a few simple ones at the end of this section, which are probably all you need to know at this stage.

### TAF

3.72 A TAF is usually published for a 9 hour period and starts with 4 figures that represent the period covered. Hence 0615 introduces a forecast for the period 0600hrs – 1500hrs. TAFs do not include temperatures or pressures, but may include information on changes expected during the forecast period – whether permanent or temporary. These changes are prefixed by **BECMG** (becoming) or **TEMPO** (temporary). If the forecaster is unsure, then a probability is given – **PROB 30TS** means a 30% probability of a thunderstorm.

### METAR

3.73 This is a report of the actual conditions at an airfield and is normally recorded hourly. It is the report which is given to aircraft that are inbound to an airfield.

3.74 The report is normally prefixed by a time, which is the time at which the conditions were observed. If the weather is changing rapidly a **SPECI** (special) report is issued using the same format. **METARs** and **SPECIs** do not forecast any conditions, but they do include temperatures and pressures.

### The Code

3.75 Examples of a **TAF** and **METAR** are given below for the same day, and you will notice that some of the code is the same in each line. The decoded version follows.

#### **TAF NELSON 0615 260/05 4000 HZ SCT030 BECMG CAVOK=**

3.76 Forecast for Nelson for the period 0600hrs – 1500hrs/surface wind 260<sup>0</sup> (true) at 5 knots/visibility 4000metres in haze/scattered cloud base at 3000ft above the airfield/becoming cloud and visibility OK, which means that visibility will be at least 10 km and there will be no cloud below 5000 ft.

#### **METAR NELSON 0900 250/07 8000 FEW 035 +17/+13 1028=**

3.77 Actual weather at Nelson at 0900hrs Zulu/surface wind 250<sup>0</sup> (true) at 7 knots/visibility 8 km/lowest cloud – few (eighths) at 3500ft/temperature +17<sup>0</sup>C, dew point +13<sup>0</sup>C/pressure 1028mb.

### Notes:

1. The end of the message is indicated by the = sign
2. The pressure given is the QNH for the airfield.

## TAF AND METAR DECODES

### Time

- **TAF** four figure group giving start and finish hours of forecast period
- **METAR** four figure group giving time (in hours and minutes) of the observation.

### Wind

- Wind speed in knots and direction in degrees true. In gusty conditions the letter '**G**' is added after the wind speed and then a higher number indicates the range of the gusts (e.g. **18G28** – 18 knots gusting to 28 knots).

### Visibility

- Four figures ranging from 0000 – 9999. 0000 means visibility is less than 50 metres. 0400 means 400 metres. From 5000 upwards visibility is measured in kilometres. 9999 means visibility is better than 10 kms.

### Weather

- Two-letter groups to indicate weather conditions which can affect aircraft adversely. Some codes are obvious; others originate from French words.
- **BR – Mist**      **FZ – Freezing**
- **SN – Snow**      **DZ – Drizzle**
- **HZ – Haze**      **TS – Thunderstorm**
- **FG – Fog**      **RA – Rain**
- **FU – Smoke**      **SH – Shower**
- **- Slight**    **+ - Heavy**

3.78 These codes can be used in any combination; for example:

- **RASN** – Rain and snow mixed
- **+SHRA** – Heavy rain shower

### CLOUD

3.79 A 6 – item code which indicates the cloud amount and height of the cloud base. The type of cloud is not given unless it is significant (e.g. with **TS** expect to see **CB** for Cumulo Nimbus). More than one group can be given if there are several layers of cloud.

### Cloud Amounts

- **FEW** 1 or 2 eighths coverage
- **SCT** Scattered – 3 or 4 eighths
- **BKN** Broken – 5 – 7 eighths
- **OVC** Overcast – 8 eighths

### Cloud Base

3.80 Three numbers to indicate cloud base height above the airfield in hundreds of feet  
e.g. **018** = 1800ft

- **018 BKN** – means 5 – 7 eighths cover at 1800 feet.



## SECTION 6 - Basic Helicopter Theory

### Definition

3.81 A Helicopter is defined in the dictionary as” an aircraft capable of hover, vertical flight, and horizontal flight in any direction.” Most get their lift and propulsion from overhead rotating blades.

### Rotor Configuration

3.82 There are four main rotor configurations that helicopters use and these are:

- a. **Conventional.** This layout has a single main rotor with a tail rotor;
- b. **Tandem.** Has a large rotor front and rear, these rotors rotate in opposite directions;
- c. **Co-axial Contra Rotating.** Has two sets of rotor blades mounted one above the other rotating in opposite directions; and
- d. **Tilt Rotor.** A combination plane/helicopter in that the engines can be rotated so that the blades perform as rotors or as propellers depending on the engines position.



### MAIN COMPONENTS

#### Fuselage

3.83 The fuselage generally contains the cockpit and cabin, guns, fuel tanks, transmission gearbox and engine/s, landing gear or skids. There may be a cargo hook for carrying external loads.

#### Tail boom

3.84 The tail boom is similar in construction to the fuselage, and incorporates a fin structure at the rear.

## Landing Gear

- 3.85 Helicopter landing gear consists of either:
- a. Wheeled Undercarriage; and
  - b. Fixed skids.

## Rotors

- 3.86 There are two types of rotors on a conventional helicopter. These are:
- a. Main Rotor; and
  - b. Tail Rotor.

## Main Rotor

3.87 The function of engine driven horizontal rotors is to provide both the lift and the propelling force.

## Tail Rotor

3.88 A helicopter with a single driven rotor requires some device to prevent the rest of the aircraft from rotating in the opposite direction to its rotor – The tail rotor counteracts the torque produced by the main rotor.

3.89 As you can see from this slide the engine transmits its power to the Main Gearbox and from there drive is transmitted to both the main and tail rotors.

- 3.90 There are three main flight controls required to be able to fly a helicopter. These are:
- a. Collective Pitch;
  - b. Cyclic Control; and
  - c. Tail Rotor Control.

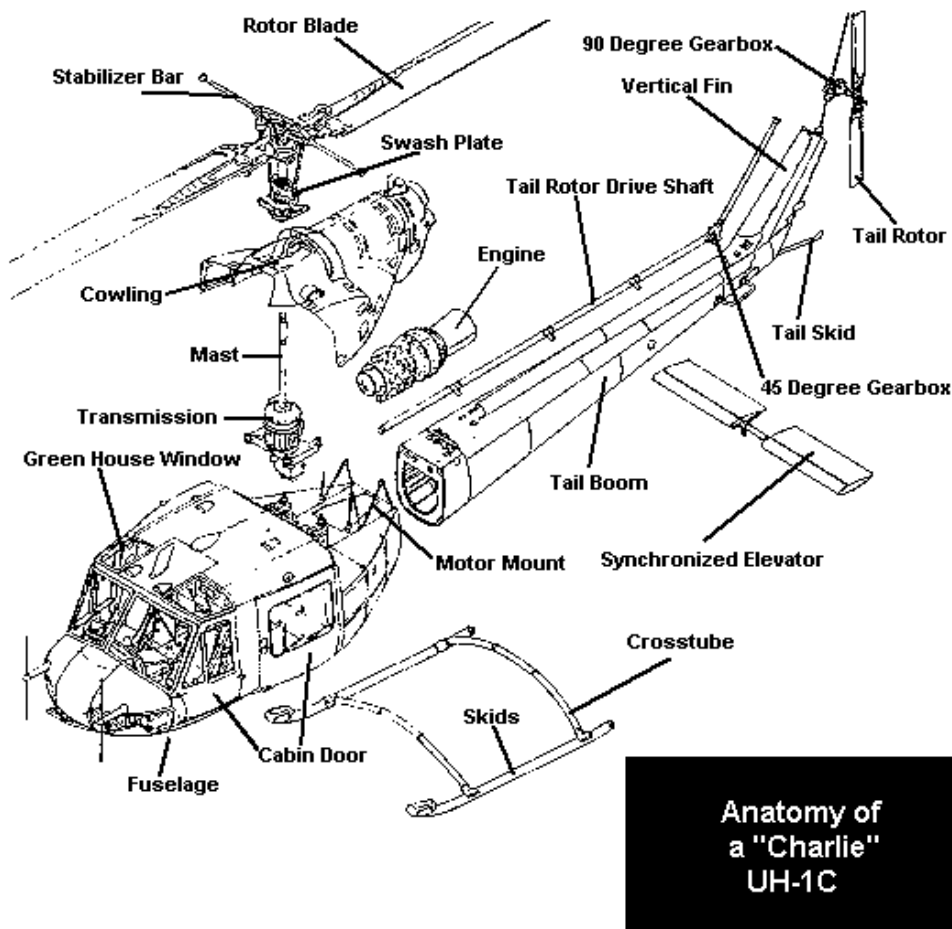

### Collective Pitch

3.91 Collective Pitch is the application of pitch to all blades equally and simultaneously. The functions of the collective control system are:

- a. Primary altitude control; and
- b. Primary power control.

3.92 The Twist grip provides primary power control. The Collective pitch lever is located on the left hand side of the Pilots seat and moves up and down.

### Cyclic Control System

3.93 Cyclic Control is the application of pitch to the blades individually during a 360° cycle. It controls the direction and velocity of horizontal flight

### Swashplate

3.94 The Swashplate is the component in the cyclic system that converts linear motion into rotary linear motion.

3.95 The Pitch angle of each blade changes constantly during each revolution and this enables the rotor disk to remain tilted in the desired direction.

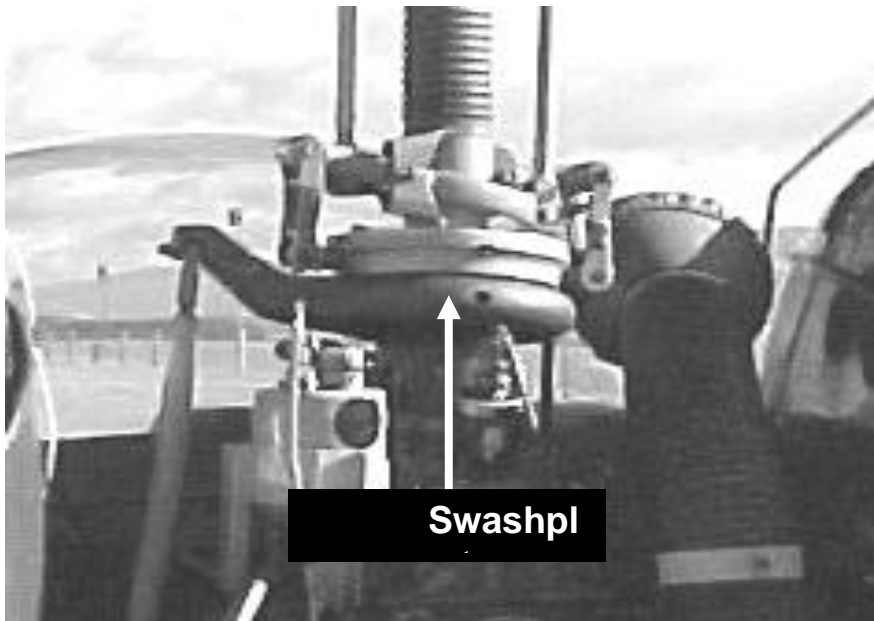

### Tail Rotor

3.96 The primary function of the Tail Rotor is to:

- a. Counteract the torque of the Main Rotor.

3.97 Secondary functions of the Tail Rotor are to:

- a. Balance transmission friction during autorotation; and
- b. Alter fuselage heading.

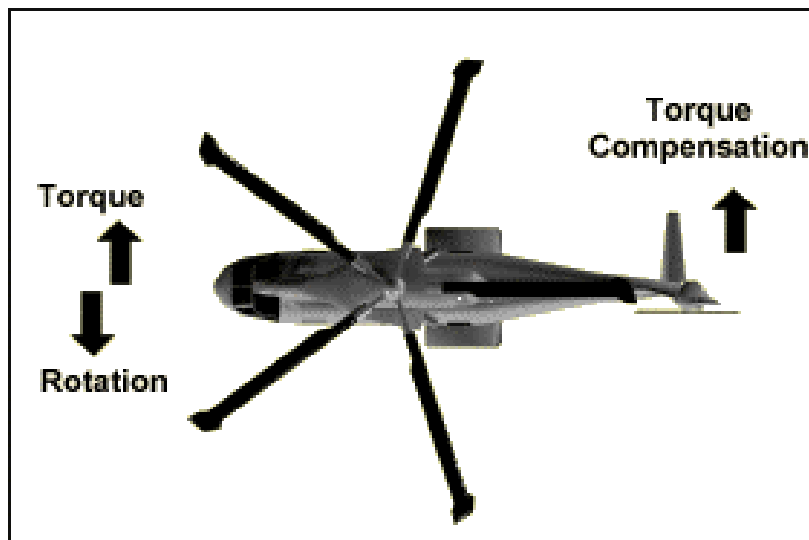

### OTHER METHODS OF TORQUE COMPENSATION

### Offset Fin

3.98 An offset fin is fitted to most helicopters and assists in counteracting main rotor torque when the helicopter is in forward flight. The fin is shaped like an aerofoil, but mounted vertically and therefore produces a sideways thrust when there is sufficient airflow over it.

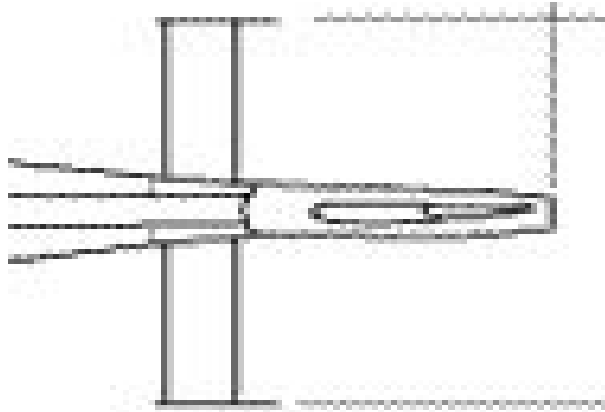

### NOTAR (No Tail Rotor)

3.99 NOTAR uses a variable pitch fan mounted in the tailboom to provide air for the production of the Coanda effect (this turns the tailboom into an aerofoil) and for the adjustable nozzle at the end of the tailboom to counteract the main rotor torque.

3.100 Its major advantage is that it is a lot safer for people working around the helicopter, as there are no tail rotor blades.

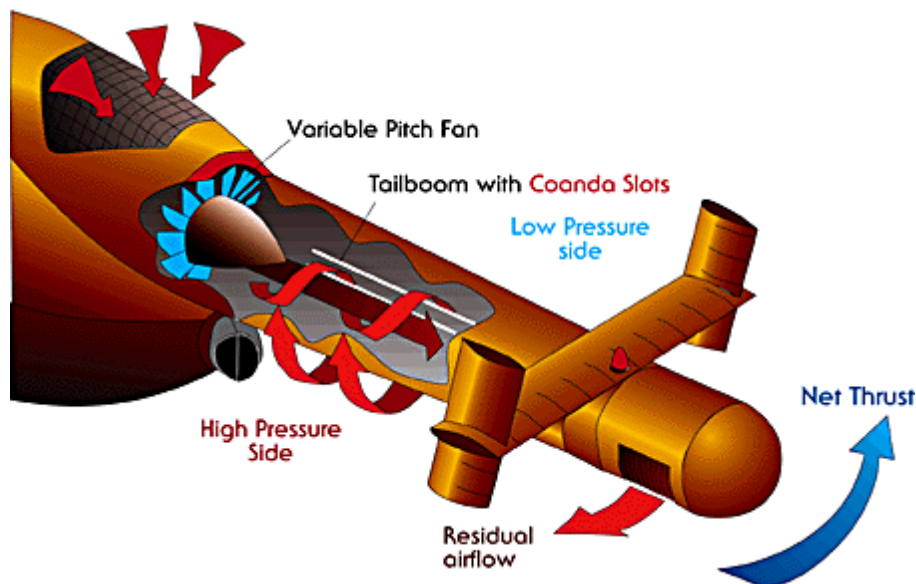

### Fenestron Tail Rotor

3.101 The Fenestron Tail Rotor works the same as a normal tail rotor, but it is made up of a multiple bladed fan mounted within the vertical fin on the tailboom. Again its major advantage is safety.



### Contra Rotating Rotors

3.102 Contra rotating rotors do away with the need for a tail rotor altogether as having each rotor rotating in opposite directions which cancels out the torque effect.



### Autorotation

3.103 Autorotation is the process of producing lift with the rotor blades as they rotate freely as a result of the airflow passing up through the rotor.

3.104 This is the opposite to normal flight when the airflow is induced downwards through the rotors as a result of the rotors being driven by the engine.

3.105 Autorotation is the means by which a helicopter may land safely after experiencing an engine failure.

## SECTION 7 - Aviation Navigation One

### Charts and Publications

3.106 To navigate an aircraft accurately and efficiently, you must be able to refer to a convenient representation of the surface of the earth being flown over at the time.

3.107 A globe of the earth would be a good idea to get an accurate representation, however getting one with a large enough scale to enable accurate navigation would be difficult as it would probably be larger than your aircraft.

3.108 For practical navigation purposes we use what is called an aeronautical chart. It is a flat representation of part of the Earth's surface and is able to be folded for convenience.

### Chart Scales

3.109 Charts represent a scaled down view of the earth's surface.

3.110 Chart **scale** is defined as the **ratio** of a **given chart length** to the actual **distance on the earth** that it represents, i.e.:

$$\text{Scale} = \frac{\text{Earth Distance}}{\text{Chart Distance}}$$

3.111 Both figures are expressed in the same units e.g. Km, Nautical Miles (nm).

3.112 The greater the chart length for a given earth distance, the larger the scale and the more detail that can be shown. On aeronautical charts the scale is normally 1:500000 or 1:250000. The 1:250000 chart is the larger scale chart as 1 cm on the chart is equivalent to 250000cm (2 ½ km), whereas the 1:500000 chart has 1cm being the equivalent of 500000cm (5 km).

3.113 This means that the 1:250000 chart is able to show more detail in its 1cm than the 1:500000 chart. The topographical maps we use for tramping are normally 1:50000 scale (1cm = 50000cm or ½ km) which is a much larger scale than either of the other two and consequentially has a much greater level of detail.

### Aeronautical charts for Visual Navigation

3.114 The principle types of charts in use within New Zealand for visual navigation are:

- a. Visual Navigation Charts (NVC);
- b. Visual Planning Charts (VPCs); and
- c. Enroute Charts (ERC).

### Visual Navigation Charts (VNC)

3.115 There are 6 VNCs covering the entire country at 1:500,000 scale and 10 VNCs covering the majority of the country at 1:250 000. Busy airspace areas are covered at



1:250,000. These charts are essential for the VFR Pilot. They are designed to assist both visual enroute navigation and pre-flight planning. The charts provide the pilot with:

- a. **Topographical** information (mountains, rivers, lakes, contours, coastlines etc);
- b. **Cultural** information (cities, towns, roads, railway lines, and other significant landmarks); and
- c. A limited amount of **Aeronautical** information aerodromes, airspace boundaries, aeronautical beacons, broadcast stations, and isogonals).

3.116 VNCs use a standard set of symbols, colours and terminology to present their information.

3.117 The Visual Navigation Charts comply with worldwide convention, organised by the **international Civil Aviation Organisation (ICAO)**. In New Zealand the production and issue of the Visual Navigation charts is the responsibility of Land Information New Zealand and Airways New Zealand on behalf of the Civil Aviation Authority.

3.118 An example of a section of the Visual Navigation chart and legend is shown below.

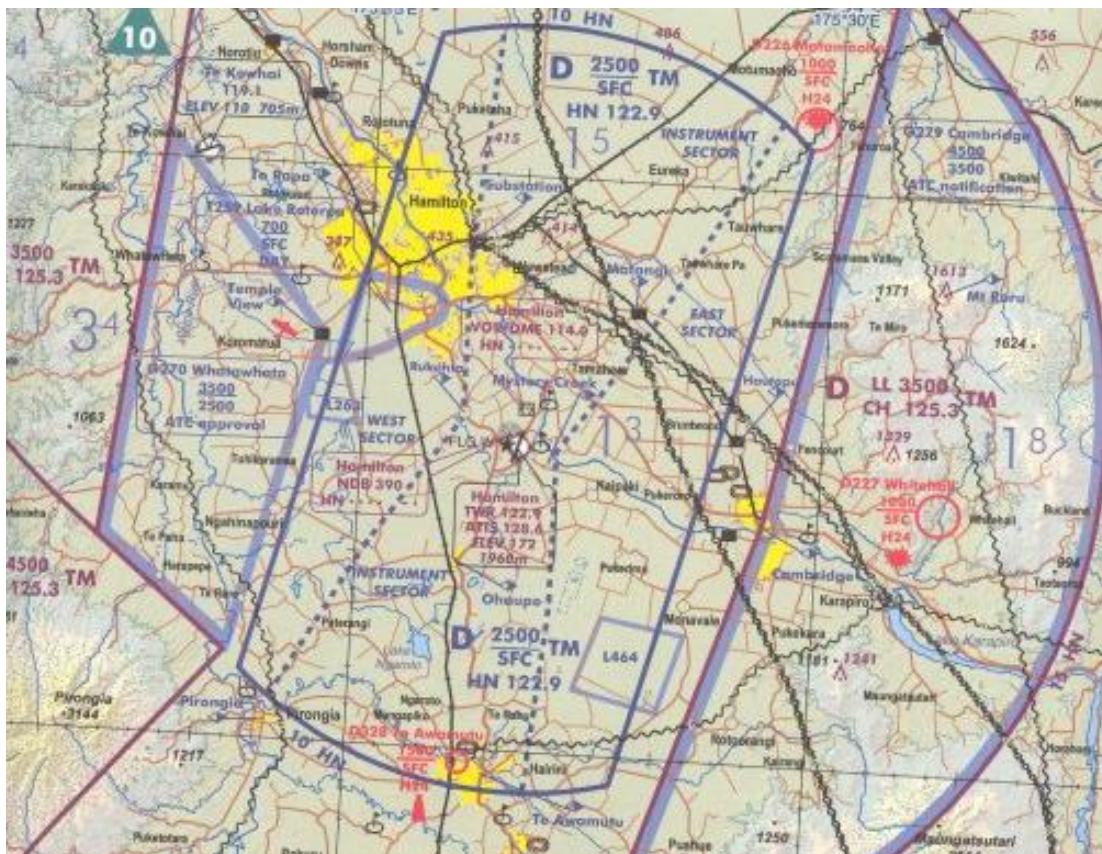

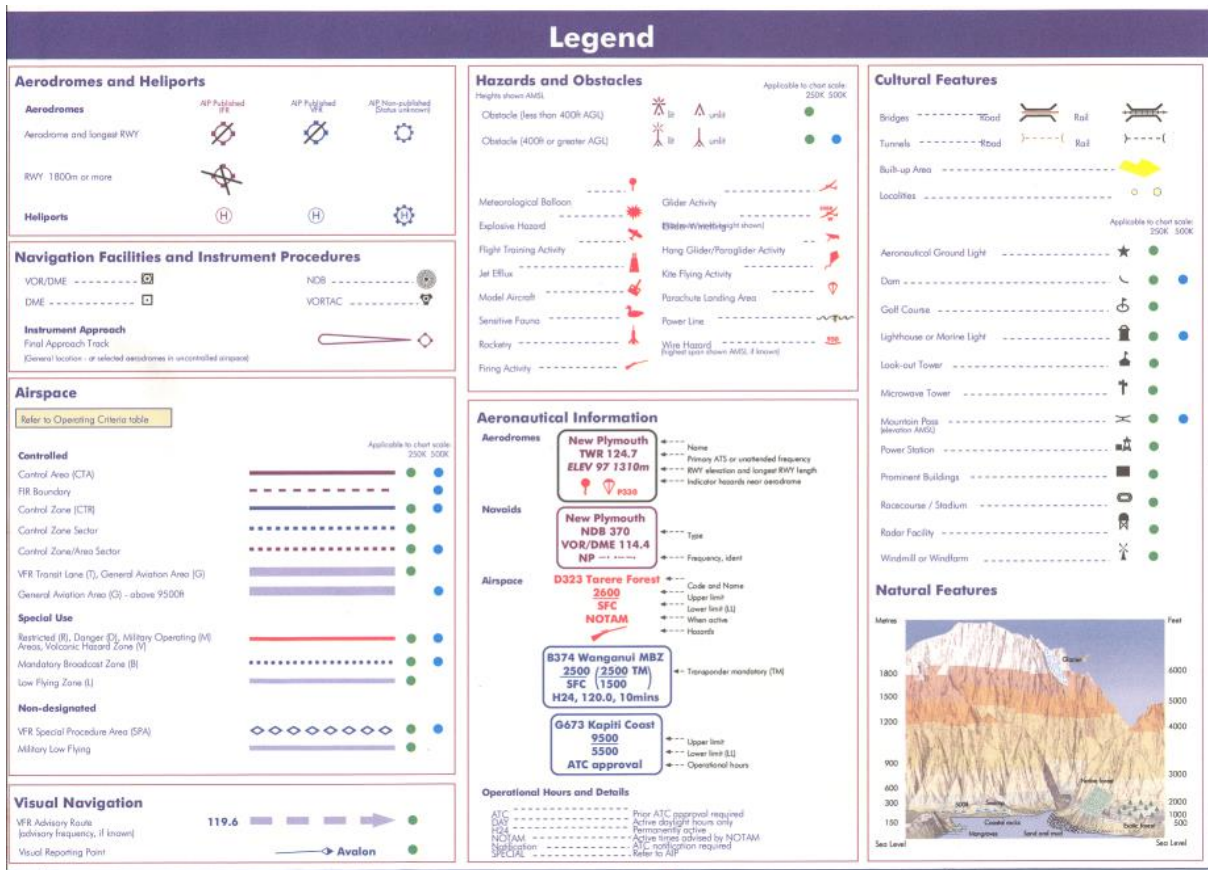

## TOPOGRAPHICAL INFORMATION

3.119 The topographical information depicted on the Visual Navigation Chart series maps is that considered to be of the greatest significance to the pilot,

### Water Features

3.120 Water features are usually depicted in blue and include things such as rivers, lakes, canals, streams, swamps etc. The exact manner in which they are presented is detailed on the chart legend (see above).

### Relief

3.121 Relief is the variation in height and slope of the earth's surface above and below mean sea level. It is shown by the use of colour tinting. Each layer between sea level and the highest elevation on the chart is allocated a specific colour according to the chart located in the legend.

### Spot Heights

3.122 Spot Heights are shown as a single black dot with an accompanying number to indicate the elevation of the feature in **feet** above mean sea level. It is important to note that these spot heights represent ground level and not tree top height. An oblong box surrounds the highest spot height on the chart.

## Cultural Features

3.123 The cultural features shown on the charts are those considered to be of the greatest significance to the pilot.

3.124 **Roads, railway lines** and **major power lines** can be of great assistance to visual air navigation. The most significant of these will be clearly marked on the VNCs. Distinctive patterns of major roads, junctions, railway lines, forks and bridges can be especially useful for enroute navigation.

## Aeronautical Features

3.125 Detailed aeronautical information is included on VNCs and this includes:

- a. **Aerodromes** (Civil, military and joint user facilities) and **landing grounds**;
- b. **Radio navigation** facilities and their frequencies;
- c. **Boundaries of airspace**. Colour coding is used to indicate each type of airspace and this is explained in the chart symbols section of the chart;
- d. **Obstruction heights**. This may include masts and other similar objects, some of which may be lit. The symbol is used with the height in feet above mean sea level of the obstruction printed next to it;
- e. **Parachute Landing Areas** are indicated by a little red parachute;
- f. **Prohibited, restricted and danger areas**;
- g. **Control zones and associated control areas**;
- h. **Transit Lanes**;
- i. **Glider flying areas (GFA's)** and **General Aviation Areas (GAA's)**;
- j. **Aeronautical beacons, lights and obstructions**;
- k. **Written warnings and location of hazardous aerial power lines**;
- l. **Cautionary notes** regarding requirements for ATC clearance and other items, e.g. extensive helicopter operations etc;
- m. **Enroute reporting points**;
- n. **An approximate runway layout** for the major aerodrome(s) covered by the VNC; and
- o. **Navigational aid** morse identification codes and frequencies.

## POSITION INFORMATION

### Parallels of Latitude

3.126 Indicating degrees north or south of the Equator (always south on NZ charts), are depicted as slightly curved lines running across the chart, representing each half of a degree. Whole degrees are labelled down the side of the chart. Additionally, graduations representing each minute of a whole degree of latitude (60 mins = one degree) are printed along those vertical lines representing whole degrees of longitude.

### Meridians of Longitude

3.127 Are depicted as straight lines that are approximately vertical, but which gradually converge towards the nearer pole (towards the bottom of the NZ charts). This convergence is not readily apparent within the small area covered by the VNC. Meridians are labelled at the top and bottom of the chart, in degrees East or West of the Prime Meridian (always East on NZ charts). Graduations corresponding to each minute of longitude are printed along these lines representing whole degrees of latitude.

### Isogonals

3.128 Isogonals (lines joining all places of equal magnetic variation) are depicted on NZMS 242 charts as dashed, blue coloured lines, labelled in  $\frac{1}{2}$  **degrees East**.

### Visual Planning Charts

3.129 There are 2 charts in this series. Each covers either the North or South Islands. The scale of the charts is 1:1 000 000.

3.130 Due to the scale of the chart, important airspace information may not be included. Pilots should only use these charts for pre-flight planning assistance. The scale of the chart makes it easier to measure track information on longer-duration flights.

3.131 When airborne, pilots should refer to the Visual Navigation Charts described above.



## Aeronautical Chart Symbols

Legend

### Aerodromes and Heliports

**Aerodromes**

Aerodrome and longest RWY

RWY 1800m or more

**Heliports**

### Navigation Facilities and Instrument Procedures

VOR/DME

DME

**Instrument Approach**

Final Approach Track  
(General location - at selected aerodromes in uncontrolled airspace)

AP Published  
AP Published  
AP Published  
AP Not Established  
AP Not Established  
AP Not Established  
AP Not Established

AP Not Established  
(Slave unknown)

NDB

VORTAC

### Hazards and Obstacles

Heights shown AMSL

Obstacle (less than 400ft AGL)

Obstacle (400ft or greater AGL)

Meteorological Balloon

Explosive Hazard

Flight Training Activity

Jet Efflux

Model Aircraft

Sensitive Fauna

Rocketry

Firing Activity

Glider Activity

Balloon/Wingflight (light shown)

Hang Glider/Paraglider Activity

Kite Flying Activity

Parachute Landing Area

Power Line

Wire Hazard  
(highest upon shown AMSL if known)

### Aeronautical Information

**Aerodromes**

**New Plymouth**  
TWR 124.7  
ELEV 97 1310m  
PS30

**New Plymouth**  
NDB 370  
VOR/DME 114.4  
NP

**D323 Tarere Forest**  
2600  
SFC  
NOTAM

**B374 Wanganui MBZ**  
2500 (2500 TM)  
SFC (1500)  
H24, 120.0, 10mins

**G673 Kapiti Coast**  
9500  
5500  
ATC approval

**Operational Hours and Details**

ATC approval required

Day

Active daylight hours only

NOTAM

Active times advised by NOTAM

ATC notification required

Refer to AIP

### Airspace

Refer to Operating Criteria table

**Controlled**

Control Area (CTA)

FIR Boundary

Control Zone (CTR)

Control Zone Sector

Control Zone/Area Sector

VFR Transit Lane (T), General Aviation Area (G)

General Aviation Area (G) - above 9500ft

**Special Use**

Restricted (R), Danger (D), Military Operating (M) Areas, Volcanic Hazard Zone (V)

Mandatory Broadcast Zone (B)

Low Flying Zone (L)

**Non-designated**

VFR Special Procedure Area (SPA)

Military Low Flying

### Visual Navigation

VFR Advisory Route (advisory frequency, if known)

Visual Reporting Point

119.6

Avalon

### Cultural Features

Bridges

Tunnels

Built-up Area

Localities

Aeronautical Ground Light

Dam

Golf Course

Lighthouse or Marine Light

Look-out Tower

Microwave Tower

Mountain Pass (elevation AMSL)

Power Station

Prominent Buildings

Racecourse / Stadium

Radar Facility

Windmill or Windform

Applicable to chart scale: 250K, 500K

### Natural Features

Sea Level

Feet

6000

5000

4000

3000

2000

1000

500

150

Metres

1800

1900

1200

900

600

300

Sea Level

## SECTION 8 - Aviation Navigation Two

### Definition

3.132 Air navigation is the art of guiding an aircraft from place to place, and determining its geographical position at any time between these places.

3.133 The importance of navigation cannot be overstressed, and it is necessary that the pilot has a good understanding of navigation, both theoretical and practical.

3.134 Before we look at the practical aspects of navigation, we must understand some basic theoretical concepts, as well as look at some of the tools that we will use to carry out navigational exercises.

### Form of The Earth

3.135 The shape of the Earth is that of an oblate spheroid or put more simply, like a squashed ball. The diameter of the equator is **6883 nm**. When viewed from above the North Pole, the Earth spins in an anti-clockwise fashion, completing a full revolution in approximately 24 hrs.

### Lines on the Earth

3.136 Any line that is drawn across the earth will be curved. These lines form the basis of navigation charts.

### Great Circle

3.137 Any circle on the Earth whose plane passes through the centre of the Earth, therefore bisecting the Earth into two equal portions.

### Small Circle

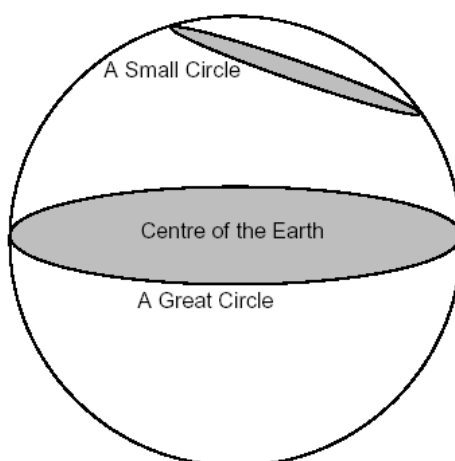

3.138 Any circle on the Earth whose plane does **not** pass through the centre of the Earth

## Meridians of Longitude

3.139 A meridian is defined as a **semi-great circle** joining the Geographical North and South poles. Each meridian has a value of 0° to 180° East or West of the Greenwich Meridian. The **Greenwich Meridian** (or Prime Meridian) is the datum meridian from which all other meridians are given their value. A Meridian runs from **top to bottom** on an aeronautical chart. A Meridian plus its Anti-Meridian is a Great Circle.

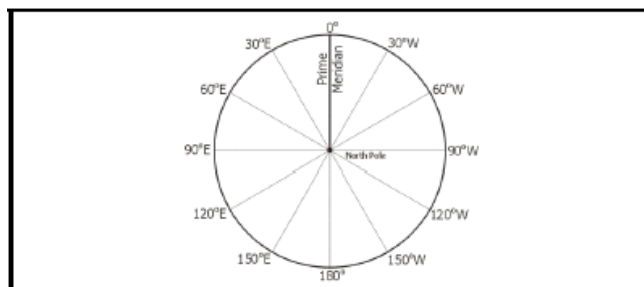
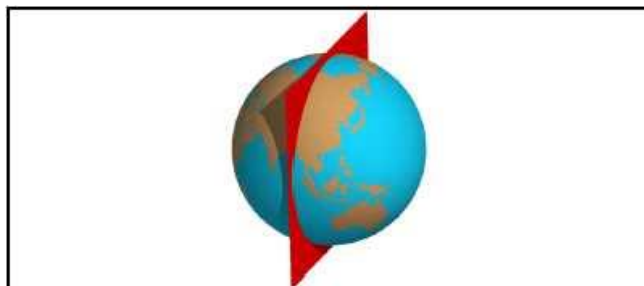

## The Equator

3.140 The equator is a **great circle** on the Earth running East – West. It divides the Earth into **2 hemispheres** – the **Northern** hemisphere and the **Southern** hemisphere.

## Parallels of Latitude

3.141 These lines run east-west and are **parallel to the Equator**. Each parallel has a numeric value from 0° to 90° North or South of the Equator. A Parallel runs from **left to right** on an aeronautical chart. The **Equator** is the datum parallel from which all other parallels are given their values:

- a. **Equator 0°**
- b. **North Pole 90°N**
- c. **South Pole 90°S**





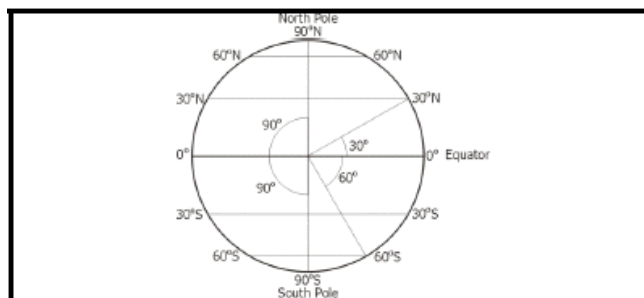

## Rhumb Lines

3.142 A Rhumb Line is a line that cuts all meridians at an equal angle. If you were to draw a straight line on your charts from any point to any other point that would be a rhumb line. Even though a rhumb line is the most convenient line for us as visual navigators to use it is not the shortest distance between two points. The shortest distance would be impossible for us to plot accurately with the equipment we have, as it is actually the arc of the great circle between those two points. The difference in distances between these two lines will be minuscule for relatively short distances as travelled in New Zealand, therefore **we use rhumb lines for navigation.**

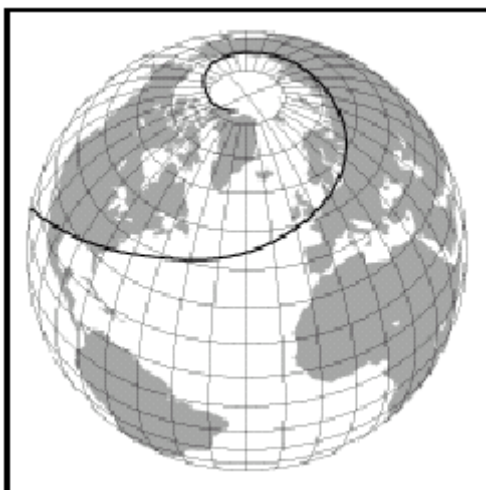

## Degrees: Minutes: Seconds

3.143 Each degree (°) of both LATITUDE and LONGITUDE is divided into 60 minutes (60'). Each minute is divided into 60 seconds (60"). With reference to **LATITUDE** only – each minute is equal to 1 Nautical Mile.

3.144 Therefore, 1 Degree of Latitude, which contains 60 minutes, equals 60 Nautical Miles. This scale is constant throughout the whole latitude range from 90°N to 90°S.

## Distance

3.145 For aeronautical purposes, distance is generally measured in nautical miles (nm.) as follows:

- a. 1 nautical mile = 6080 feet;
- b. 1 statute mile = 5280 feet; and

c. 1 kilometer = 3281 feet.

3.146 The charts that we will use for navigation have various scales of distance.

3.147 Be sure to use the **CORRECT SIDE** of your **NAVIGATIONAL RULER** when **MEASURING DISTANCE!**

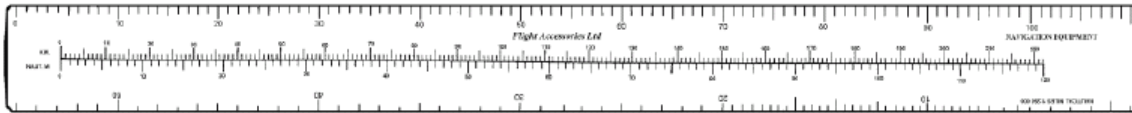

### Position on the Earth

3.148 As previously mentioned, the network of Meridians and Parallels form gridlines over the surface of the Earth. It is from these lines that we take position fixes.

3.149 **Important:** When giving a position fix, always state the **Latitude** value **first**, followed by the **Longitude** value.

3.150 For Example, the LAT and LONG of Ardmore Aerodrome is: S 37° 01' 47.0", E 174° 58' 24.0" Find the aerodromes located at these co-ordinates using your aeronautical charts:

- a. S 37° 00' E 174° 47'
- b. S 40° 12' E 175° 23'
- c. S 41° 19' E 174° 48'

3.151 In the correct format, express the following **aerodromes** as Latitude and Longitude values:

- a. Whenuapai
- b. Taupo
- c. New Plymouth



## DIRECTION ON THE EARTH

### North and South

3.152 The Earth rotates daily about its axis, the extremities of which are called the poles: the North and the South Poles.

3.153 At any place on the earth the direction in which North or South lies is along the meridian passing through that place. The direction of the North Pole is known as **True North**.

### East and West

3.154 The direction from which the heavenly bodies (such as the Sun) appear to rise is called East and the opposite direction West.

Cardinal Points	Quadrantal Points
North	North-east
East	South-east
South	North-west
West	South-west

## CARDINAL AND QUADRANTAL POINTS

### The Compass Rose or Protractor

3.155 In air navigation, direction is always measured with reference to **North**. If a circle is drawn and divided into 360 equal parts and numbered clockwise from 0 – 360, then the circle will be divided into 360 degrees, each division being one degree.

3.156 This forms a **Compass Rose** or Protractor. If we centre this circle on a Point A on a map and orientate it so that 0° lies along the North arm of the meridian through A, then a line joining A to any other point B on the map must cut one of the degree divisions. This will give us the direction of 'B' from 'A' in degrees. It will give us the direction to travel to reach B and also give us the bearing of B from A relative to True North and is known as the **True Direction and True Bearing**. It is important that you only use the **outer** scale to read bearings.

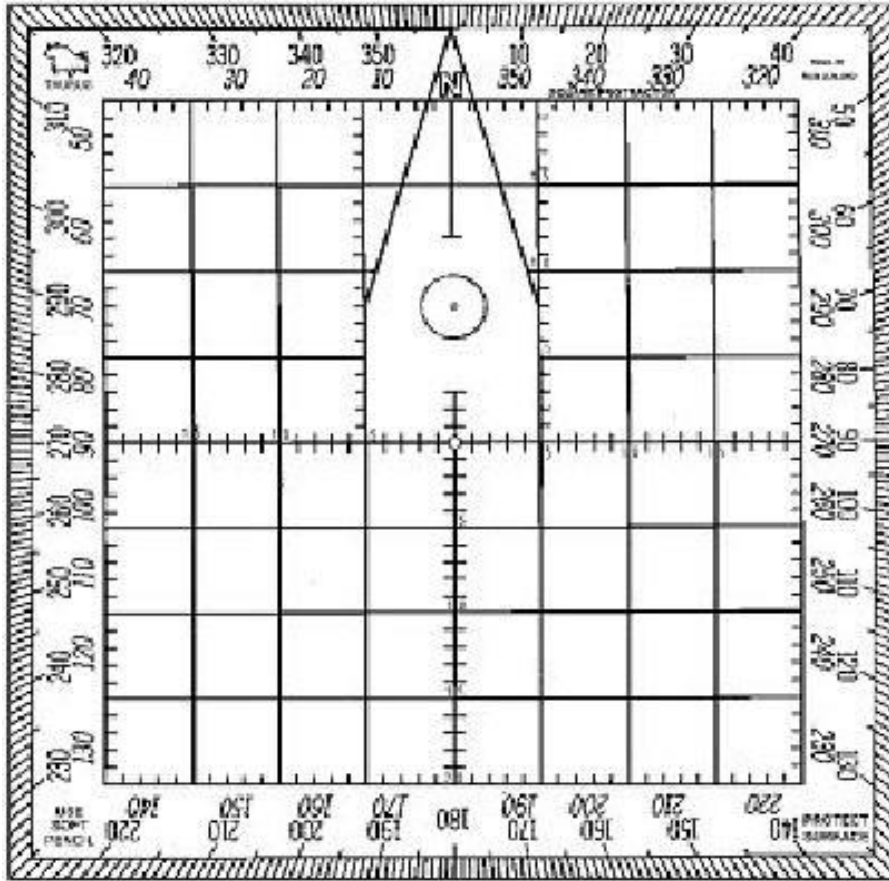



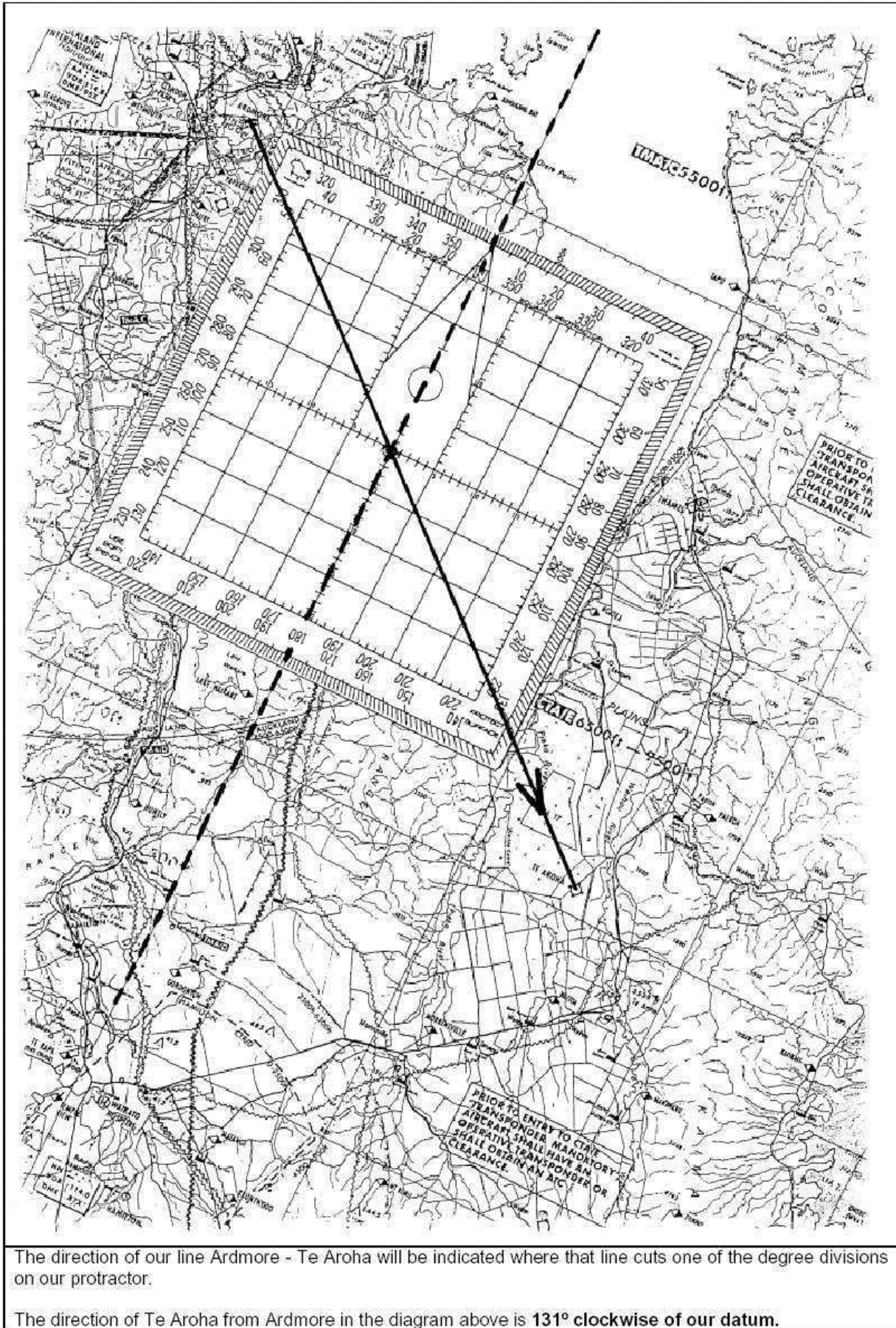

3.157 Due to our datum (where the 0° mark is pointing) being the north geographical pole, our directions are termed in **degrees true** or **°T**.

All directions from now on must be written and stated in **THREE-FIGURE GROUPS**

001° stated “zero, zero, one degrees”

010° stated “zero, one, zero degrees”

100° stated “one, zero, zero degrees”

3.158 Draw lines between the following aerodromes; measuring direction in °T and distance in nautical miles.

FROM	TO	DIRECTION	DISTANCE
Ardmore	Hamilton		
Hamilton	Rotorua		
Rotorua	Taupo		

### Magnetic Direction

3.159 The earth acts as a huge magnet with a North and a South Pole. However these poles are not situated in the same place as the geographical poles – and they are constantly moving – slowly rotating around the geographical poles. Like an actual magnet, the earth produces lines of force, and therefore a freely suspended magnet will align itself with these lines of force. This gives us the direction of **Magnetic North** and **Magnetic South**.

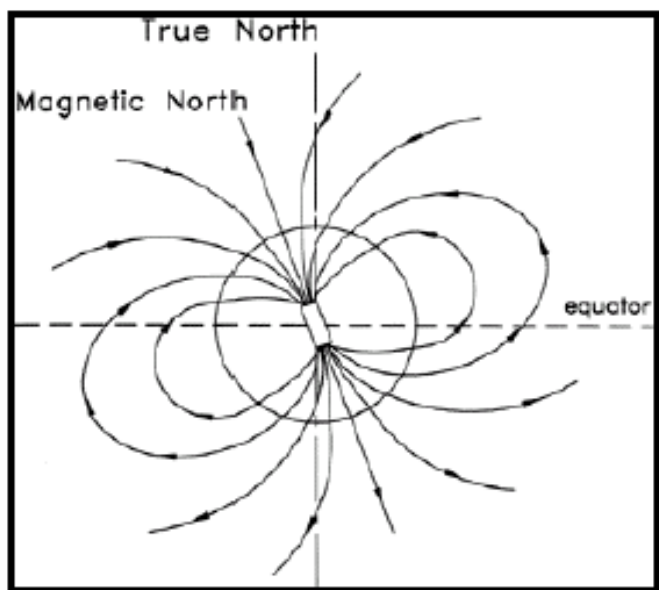

3.160 In air navigation, the freely suspended magnet is the **compass**. The direction to which the magnet (and therefore the compass) points to is called **Magnetic North**.

### Magnetic Variation

3.161 As the magnetic and geographic poles are situated in different places it follows that there must be an angular difference between a true meridian passing through a place and a magnetic meridian passing through the same place. This angular difference is termed **Variation**.

3.162 Variation is termed East if Magnetic North lies East of True North, and West if Magnetic North is West of True North. To convert magnetic direction to true direction at any place it is necessary to find out the local variation. Variation is shown on most charts as a blue dashed line called an **isogon**. Once you have determined variation for the appropriate leg of the flight, apply the following rule:

VARIATION EAST – MAGNETIC LESS THAN TRUE  
VARIATION WEST – MAGNETIC GREATER THAN TRUE

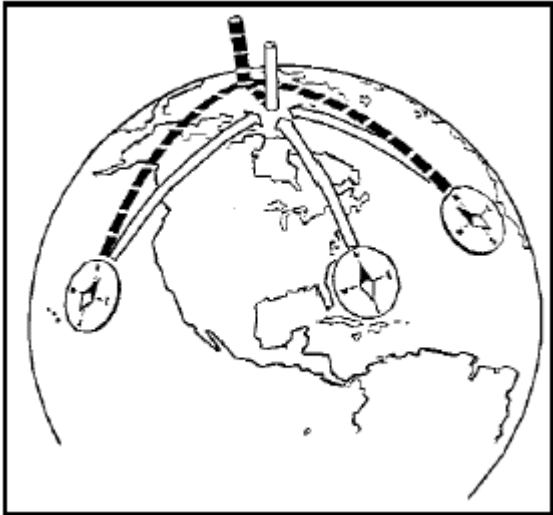

3.163 In New Zealand, magnetic variation is always Easterly. This means that a given **magnetic direction** will have a lesser value than the **true direction**.

3.164 Complete the following table. The first two examples have been completed for you.



<i>TRUE DIRECTION</i>		<i>VARIATION</i>		<i>MAGNETIC DIRECTION</i>
060°T	→	20°E	=	040°M
080°T	=	20°E	←	060°M
045°T		20°E		
254°T		22°E		
009°T		19°E		
180°T		25°E		
		15°E		350°M
		21°E		225°M
		24°E		090°M

## Flight Planning

3.165 Before learning to use the navigation computer, the student requires a thorough understanding of the following concepts.

### Track

**REQUIRED TRACK:** The direction over the ground that an aircraft is required to follow in order to get from A to B

**TRACK MADE GOOD:** The direction over the ground that the aircraft has already flown.

3.166 Track is normally expressed as degrees true ( $^{\circ}T$ ) but if variation is applied it can be expressed as degrees magnetic ( $^{\circ}M$ ).

**HEADING:** The direction that the aircraft's nose is pointing.

### Heading

3.167 Heading can be expressed as degrees true, degrees magnetic or degrees compass.

### Drift

**DRIFT:** The angular difference between the heading of the aircraft and the Track Made Good (TMG). It is caused by wind. Drift is always measured from HEADING to TRACK.

3.168 Drift is measured in degrees. It is termed as either **port (left)** or **starboard (right) drift**.

3.169 To aid in remembering which directions port and starboard refer to, it is helpful to remember the following phrase:

**"There is no more red port left"**

3.170 This indicates that port is left and also reminds that the red navigation light is on the aircraft's left (port) wing.

3.171 If an aircraft drifts away from its required track it has not allowed enough, or may have allowed for too much, drift.

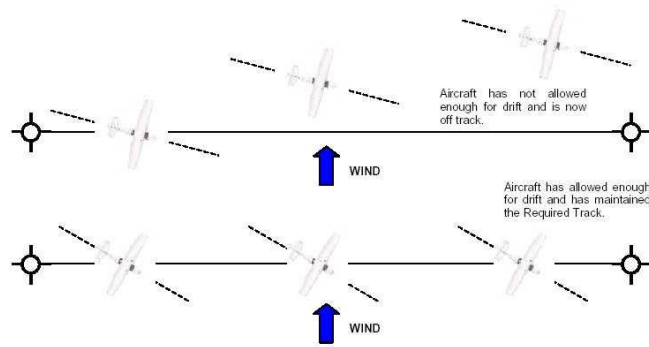

**GROUNDSPEED:** The rate at which the aircraft moves across the ground.  
This is measured in knots.  
1 knot = 1 Nautical mile per hour

### Groundspeed

3.172 Groundspeed is affected by the wind. It is important to calculate groundspeed so that accurate ETAs (Estimated Times of Arrival) can be predicted.

### True Airspeed

**TRUE AIRSPEED:** The speed of the aircraft through the surrounding air mass.

3.173 True Airspeed is derived from the Indicated Airspeed displayed on an aircraft's Airspeed Indicator (ASI). Errors from the ASI are corrected to give True Airspeed (TAS).

### Wind Velocity (W/V)

3.174 Wind velocity is a combination of wind direction and wind speed.

**WIND DIRECTION:** The direction that the wind is blowing FROM.

**WIND SPEED:** Is usually stated in knots.

3.175 Wind forecasts can be obtained by phone, fax or internet. Wind direction is generally given in degrees true.

### Time Groups

3.176 Flight plans always use a four-figure time group. The first two figures refer to hours. The last two figures refer to minutes. You should become familiar with this format. Some examples of a four-figure time group are shown below:

- a. 30 mins is written as 0030;
- b. 1 hour 30 mins is written as 0130; and

- c. 10 hours and 30 mins is written as 1030.

## THE NAVIGATION COMPUTER

### Finding Heading & Groundspeed

3.177 Finding a heading is generally the first step when we start completing a flight plan. When the pilot calculates a heading, that heading must compensate for the amount of DRIFT on that particular heading.

3.178 Groundspeed calculation is required to work out accurate flight times, from which the ETA and fuel figures are calculated.

3.179 The following is a general format of procedures and order of steps to take for this initial section of flight planning:

- a. Identify Departure and Destination points (i.e. from A to B)
- b. Draw the Required Track on the chart
- c. Measure the Track Direction with Square Protractor ( $^{\circ}$ T)
- d. Measure Track Distance (nautical miles)
- e. Obtain a W/V from a weather forecast (degrees true / knots)
- f. Obtain TAS (Aircraft's cruising speed)

3.180 Prior to working out heading and groundspeed problems it is important to have an approximate idea of what your computer should tell you. This can be done by using a diagram. Always regard true north as being at the top of the page.

### Example:

**Track 100 $^{\circ}$ T**

**TAS 100 kt**

**W/V 130/30**

- a. Draw in track. (Remember this is just to give you a rough idea, so estimate directions. Leave the accuracy part to the computer.);

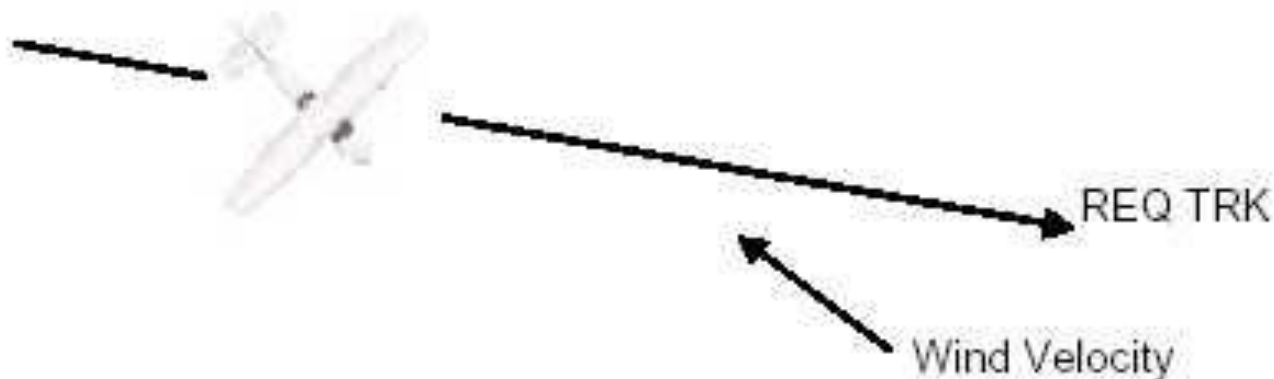

- b. Draw direction wind is blowing **from**;
- c. We know to allow for drift we will need to point the nose of the aircraft into wind, so draw the silhouette of your aircraft over the track allowing for drift; and
- d. From our diagram, we would now expect our computer to produce a **heading greater than our track**. Due to the wind direction basically producing a headwind component we would want to see our computer depicting a **groundspeed less than our TAS**.

3.181 With our estimates in mind we can now move on to the computer.

1. Place the **wind direction** under the **index** and mark the **wind speed dot down from the centre grommet** ... (start with the grommet on any whole number for ease when counting down)
2. Slide the **TAS** under the **centre grommet**.
3. Rotate the **track** under the **index** and note what **drift line** the dot sits on.
4. **Rotate the track** to the appropriate **drift mark** and recheck the dot. Readjust if necessary until the dot is on the same drift line as the track.
5. Read off the **heading** under the **index** and **groundspeed** under the **wind dot**.

3.182 For this particular example:

- a. Place the **wind direction** of 130 under **index**;
- b. Place grommet over the 100kt wind arc;
- c. Count down 30 graduations (down to 70) for **wind strength** and mark that position with a **dot**. (The smaller your dot is the more accurate your answer. A fine, fibre-tip pen is ideal for this purpose.) We have now plugged the wind velocity into the computer;
- d. Place **centre grommet** over 100 (**TAS**);

- e. Rotate central ring so that 100 (**track**) lies beneath **index**;
- f. Identify the drift line on which the dot sits. (In this case the dot lies on the 12° port drift line. All computers vary to some extent. As long as you are getting results + 2 either side of the figures stated, you are on the right track.);
- g. Rotate 100 (**track**) so that it is **aligned with the 12° port drift mark**;
- h. Go back to the wind dot and note that it now lies on the 8° port drift line;
- i. You will now need to adjust the central ring so that 100 (**track**) is positioned against the **same drift mark** as that on which the **wind dot** rests;
- j. Adjusting gives us a result of 9° port drift;
- k. Read **heading** under **index** (109°T); and
- l. Read groundspeed where the wind dot crosses a wind arc (73 kt).

3.183 From our previous calculations we stated that the computer should give us results to the extent that:

**heading > track and groundspeed < TAS.**

3.184 Our heading (109) is greater than track (100). Our groundspeed (73 kt) is less than our TAS (100), so as far as we can make out our computer has provided us with a logical answer.



USING THE NAV COMPUTER TO FIND HEADING °T AND GROUND SPEED

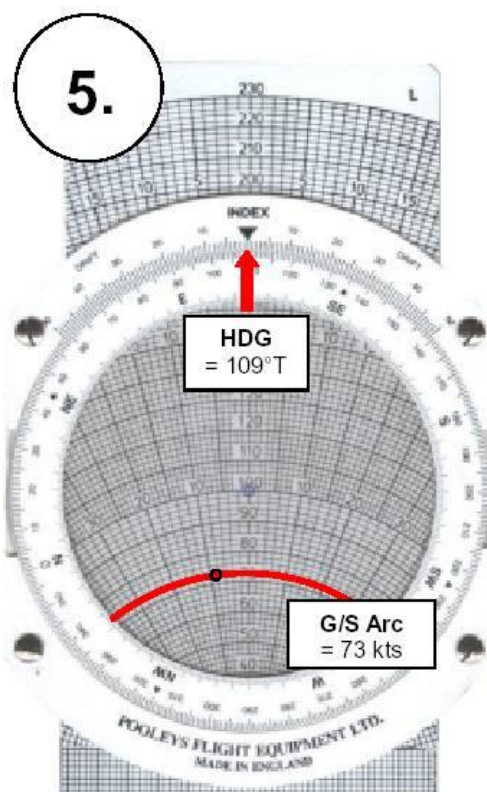
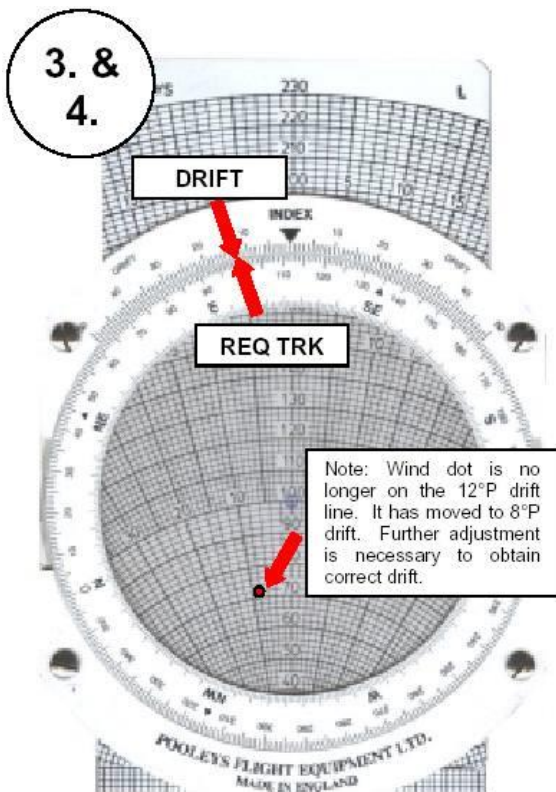
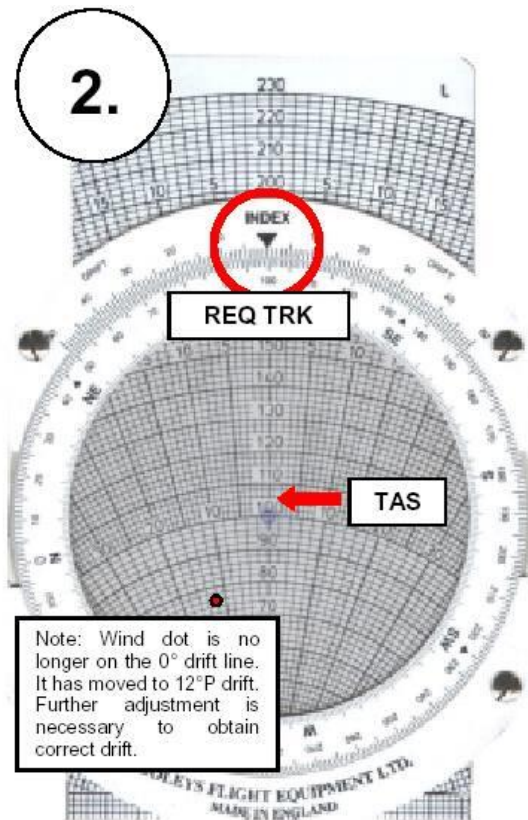
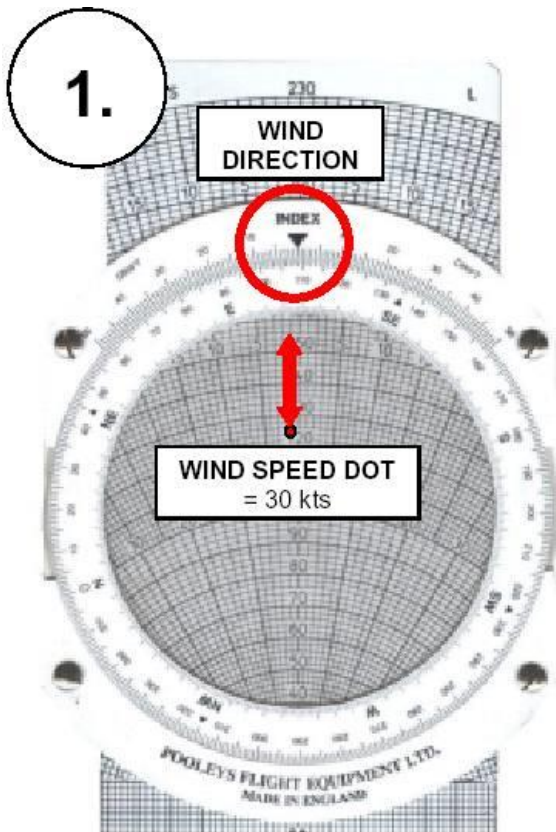

3.185 Practice the examples below using your navigation computer. Remember to estimate first using a drawing.



No.	W/V	TAS	TRK	HDG	G/S
1	270 / 30	115	180		
2	270 / 30	90	212		
3	270 / 30	85	045		
4	270 / 30	95	345		
5	270 / 30	100	150		
6	360 / 15	120	165		
7	360 / 15	145	165		
8	360 / 15	120	095		
9	360 / 15	100	045		
10	360 / 15	98	125		

### Distance, Speed and Time Problems

3.186 For these calculations, we will be using the side of the navigation computer. This side is used for figuring out distance, speed & time problems as well as calculating fuel consumption and other variables.

3.187 Common sense must be used for these problems or you will most likely end up with an incorrect answer.

3.188 This is because the scale of the computer is logarithmic. For example the "10" represents 0.1, 1.0, 10, 100, 1000 etc.

For the Navigation Computer:

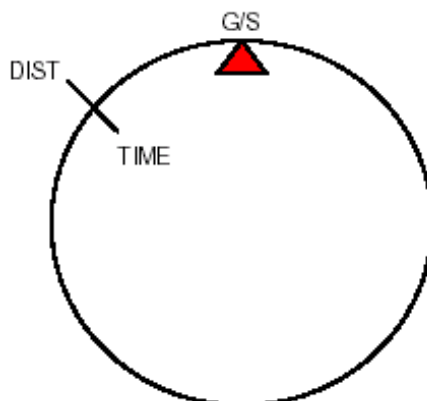

**Example: How long will it take an aircraft flying at a groundspeed of 380 kts to cover a distance of 220 nm?**

3.189 First of all, we need to come up with an estimate of our answer. To do this we round off the given variables.

3.190 Our aircraft is travelling at *approximately* 400 kts over a distance of *approximately* 200 nm. The elapsed time should therefore be around 30 mins.

- a. Set **380 (G/S)** on the outside scale against the clearly marked '60' indicator. This means we are travelling 380 nm **per** 60 mins.
- b. Locate **220 (DIST)** on the outside scale.
- c. Read the **TIME** on the inside scale directly beneath the distance of 220.
- d. The given answer is **34.75 mins.**

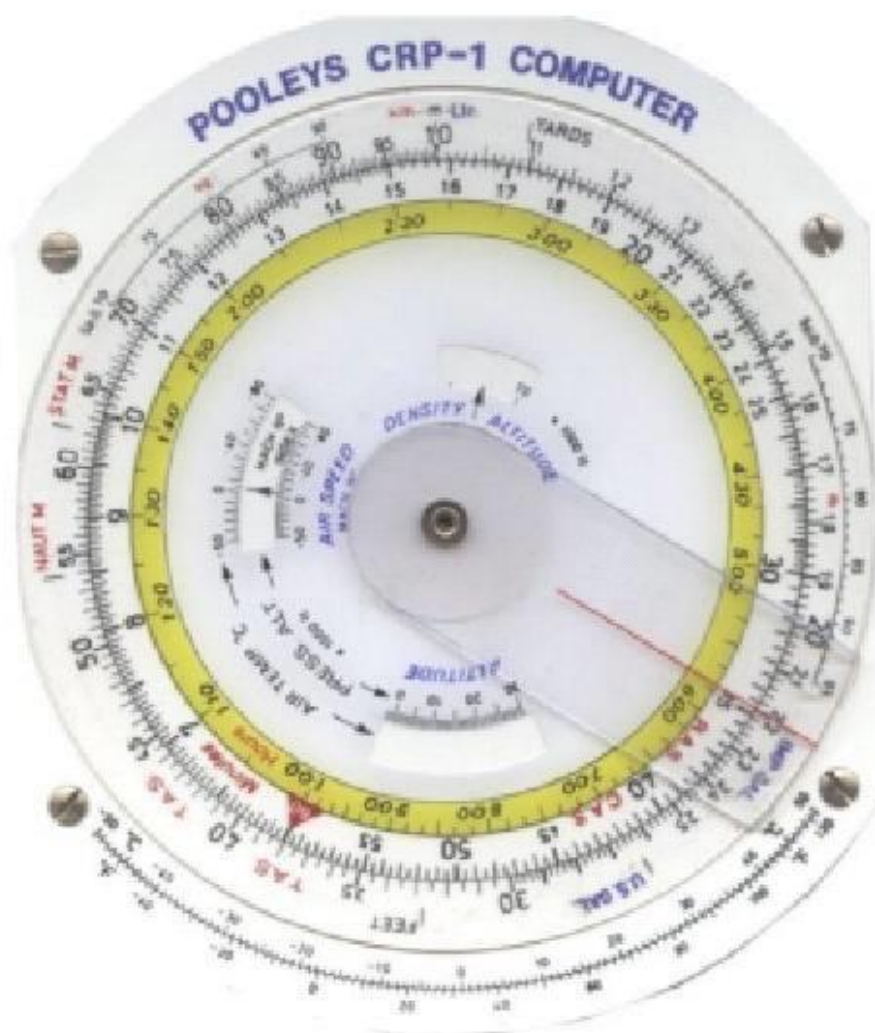

Complete the empty boxes on this page.

No	G/S	DIST	TIME
1.	90	47	
2.	95	110	
3.	87	143	
4.	104	100	
5.	130	222	
6.		42	0037
7.		100	0100
8.		7	0012
9.		34	0045
10.		134	0114
11.		122	0207
12.	100		0017
13.	90		0105
14.	105		0039
15.	76		0014

### FUEL REQUIRED FOR FLIGHT

3.191 The last thing that we will look at on the navigation computer is how to calculate the fuel required for flight. The calculations are similar to those that we use for distance-time problems. For the Navigation Computer:

- a. Align the fuel consumption rate with the index marker.
- b. Identify flight time on the inside scale.
- c. Fuel required will be indicated on the outside scale aligned with the appropriate time mark.

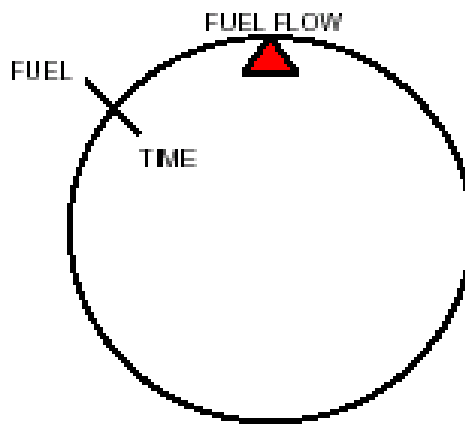

Complete the following table:

No	TIME	FUEL FLOW	FUEL REQUIRED
1.	0030	35 lph	
2.	0230		75 litres
3.	0115	40 lph	
4.	0100		120 litres
5.		27 lph	81 litres

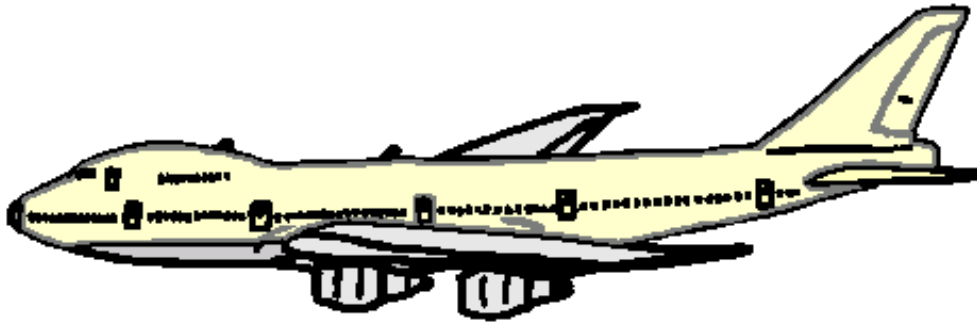

### Completing a flight log

3.192 When completing a flight log, you will need to ensure that you use current information and that you work accurately. One of the key purposes behind completing a flight plan is to ensure that **sufficient fuel** is carried for the flight.

3.193 In addition to route fuel (i.e. fuel requirements for A – B – C), a pilot must ensure that allowances are made for legal fuel reserves and unusable fuel quantities. Legally a pilot, on a VFR flight by day, must carry at least 30 mins additional fuel on top of any other fuel carried for a flight. This is a **fuel reserve**. Most aircraft fuel tanks cannot actually supply all of the contained fuel to the engine. The left over quantity remains in the tank and is therefore **unusable**. A Cessna 172R for example, which can hold 212 litres of fuel, has 12 litres of unusable fuel. This must be allowed for in a flight plan.

3.194 Below is a sample flight log completed for a flight departing Ardmore. Enroute destinations include Hamilton and Pauanui aerodromes followed by a return landing at Ardmore via the Surrey NDB beacon. The aircraft used is a Cessna 172R with a TAS of 115 kts and a fuel flow of 35 litres per hour. The wind forecast for the day was 180°T at 20 kts.

3.195 Work through the log yourself and use the completed log below to check your plan.

FROM	TO	TAS	ALT	TRK	W/V	HDG °T	VAR	HDG °M	G/S	DIST	EET	F/F	FBO
AR	HN	115	VFR	161	180 / 20	164	20°E	144	96	53	0033	35	19
HN	UN	115	VFR	026	180 / 20	031	20°E	011	133	56	0025	35	14
UN	SY	115	VFR	248	180 / 20	239	20°E	219	106	36	0020	35	11
SY	AR	115	VFR	324	180 / 20	318	20°E	298	131	16	0007	35	4
											0125		
												Route Fuel	48
												Unusable	12
										Reserve	0030	35	17
												TOTAL	77

3.196 The flight plan shows that we will require a minimum of 77 litres of fuel for the flight. The Total Estimated Elapsed Time is 1 hour 25 minutes.

**Now complete the following practice flight plans.**

**FLIGHT PLAN 1**

- Route: Auckland International – Whangarei – Great Barrier
- W/V: 240°T / 10 kts
- TAS: 120 kts
- F/F: 34 lph

FROM	TO	TAS	ALT	TRK	W/V	HDG °T	VAR	HDG °M	G/S	DIST	EET	F/F	FBO
											Route Fuel		
											Unusable		12
										Reserve	0030		
											TOTAL		

**FLIGHT PLAN 2**

- Route: Masterton – Wellington – Christchurch
- W/V: 270°T / 5 kts
- TAS: 115 kts
- F/F: 34 lph



FROM	TO	TAS	ALT	TRK	W/V	HDG °T	VAR	HDG °M	G/S	DIST	EET	F/F	FBO
										Route Fuel			
										Unusable		12	
										Reserve	0030		
										TOTAL			

**FLIGHT PLAN 3**

- Route: Ardmore – Whangarei – Kaitaia
- W/V: 030°T / 15 kts
- TAS: 115 kts
- F/F: 34 lph

FROM	TO	TAS	ALT	TRK	W/V	HDG °T	VAR	HDG °M	G/S	DIST	EET	F/F	FBO
										Route Fuel			
										Unusable		12	
										Reserve	0030		
										TOTAL			

**FLIGHT PLAN 4**

- Route: Queenstown – Christchurch – Woodbourne
- W/V: 255°T / 25 kts
- TAS: 115 kts
- F/F: 34 lph

FROM	TO	TAS	ALT	TRK	W/V	HDG °T	VAR	HDG °M	G/S	DIST	EET	F/F	FBO
										Route Fuel			
										Unusable		12	
										Reserve	0030		
										TOTAL			

## SECTION 9 - Aviation Radio Procedures

### Frequencies

3.197 The air to ground control radio station shall select the frequency or frequencies to be used under normal conditions by aircraft operating under its control.

3.198 In general the frequency range known as Airband in New Zealand covers the VHF range 108 – 174 Megahertz (MHz).

### GENERAL PROCEDURES

#### Transmitting Technique

3.199 The following transmitting techniques will assist in ensuring that transmitted speech is clearly and satisfactorily received:

- a. Before transmitting check that the receiver volume is set at the optimum level and listen out on the frequency to be used to ensure that your transmission will not interfere with a transmission from another station;
- b. Be familiar with microphone operating techniques and do not turn your head away from the microphone whilst talking, or vary the distance between it and your mouth. Severe distortion of speech may arise from talking too close to the microphone, touching the microphone with the lips, or holding on to the microphone or boom (of a combined headset/microphone system);
- c. Use a normal conversation tone, speak clearly and distinctly;
- d. Maintain an even rate of speech not exceeding 100 words per minute. When it is known that the recipient will write down elements of the message, speak at a slightly slower rate;
- e. Maintain the speaking volume at a constant level;
- f. A slight pause before and after numbers will assist in making them easier to understand;
- g. Avoid using hesitation sounds such as “er”;
- h. Depress the transmit switch fully before speaking and do not release it until the message is complete. This will ensure that the entire message is transmitted. However, do not depress the transmit switch until ready to speak; and
- i. It is important to speak slowly and clearly and use standard words and phrases as much as possible – remember that English may be a second language for some.

3.200 One of the most irritating and potentially dangerous situations in radiotelephony is a ‘stuck’ microphone button. Operators should always ensure that the button is released

after a transmission and that the microphone placed in an appropriate place that will ensure that it will not inadvertently be switched on.

### Phonetic Alphabet

3.201 The following table lists the Phonetic Alphabet for transmitting letters and the corresponding Morse Code identifier. Syllables to be emphasised are in upper case:

Letter	Phonetic	Syllabus Emphasis	Morse Code Identifier
A	Alpha	AL fah	• –
B	Bravo	BRAH voh	– •••
C	Charlie	CHAR lee	– • – •
D	Delta	DELL tah	– ••
E	Echo	ECK ho	•
F	Foxtrot	FOKS trot	•• – •
G	Golf	GOLF	– – •
H	Hotel	Ho TELL	••••
I	India	IN dee ah	••
J	Juliet	JEW lee ET	• – – –
K	Kilo	KEY loh	– • –
L	Lima	LEE mah	• – ••
M	Mike	MIKE	– –
N	November	No VEM ber	– •
O	Oscar	OSS cah	– – –
P	Papa	Pah PAH	• – – •
Q	Quebec	Keh BECK	– – • –
R	Romeo	ROW meoh	• – •
S	Sierra	See AIR rah	•••
T	Tango	TANG go	–
U	Uniform	YOU nee form	•• –
V	Victor	VIC tah	••• –
W	Whiskey	WISS key	• – –
X	Xray	ECKS ray	– •• –
Y	Yankee	YANG key	– • – –
Z	Zulu	ZOO loo	– – ••

### Pronunciation of Numbers

3.202 The following table lists the phonetic spelling of numbers and number terms, and the corresponding Morse Code identifier. Syllables to be emphasized are in upper case.

Number	Phonetic Spelling	Morse Code Identifier
0	ZE-RO	– – – – –
1	WUN	• – – – –
2	TOO	•• – – –
3	TREE	••• – –
4	FOWer	•••• –

Number	Phonetic Spelling	Morse Code Identifier
5	FIFE	•••••
6	SIX	-••••
7	SEVen	--•••
8	AIT	---••
9	NINer	----•

Word	Pronunciation
Decimal	DAY SEE MAL
Hundred	HUN dred
Thousand	TOU SAND

3.203 All numbers used in the transmission of aircraft call-signs, flight levels, headings, wind direction and speed, transponder codes, runway designators, mach numbers, altimeter settings, time, and frequencies must be transmitted by pronouncing each digit separately.

Application	Example	Transmitted As
Aircraft Callsign	QFA 355 RLK 238	Qantas three five five Link two three eight
Flight Levels	FL 180 FL 200 FL 70	Flight level one eight zero Flight level two zero zero Flight level seven zero (Oceanic only)
Headings	150 080 300	Heading one five zero Heading zero eight zero Heading three zero zero
Wind Direction & Speed	020 deg 70 knots 100 deg 18 knots 210 degrees 18 knots gusting 30 knots	Wind zero two zero degrees seven zero knots Wind one zero zero degrees one eight knots Wind two one zero degrees one eight knots gusting three zero knots
Runway Designator	19 06 23L	Runway one nine Runway zero six Runway two three left
Mach Number	0.84	Mach decimal eight four
Altimeter Setting	984 hPa 1027 hPa 29.95 inches	QNH nine eight four QNH one zero two seven QNH two nine decimal nine five
Time	0920 1634	Two zero or zero nine two zero Three four or one six three four
Frequencies	128.3 MHz 135.75 MHz 5643 kHz	One two eight decimal three One three five decimal seven five Five six four three

3.204 All numbers used in the transmission of altitude, visibility, cloud height, and runway visual range

3.205 (RVR) information must be transmitted by pronouncing each digit separately, except that those numbers which contain whole hundreds and/or whole thousands only

must be transmitted by pronouncing each digit of the hundreds or thousands followed by the word HUNDRED or THOUSAND as appropriate.

3.206 Combinations of whole hundreds and thousands must be transmitted by pronouncing each digit in the number of thousands followed by the word THOUSAND followed by the number of hundreds followed by the word HUNDRED.

Application	Example	Transmitted As
Altitude	300ft 1145ft 1500ft 10,000ft	Three hundred feet One one four five feet One thousand five hundred feet One zero thousand feet
Visibility	200m 1500m 3000m 10km	Two hundred metres One thousand five hundred metres Three thousand metres One zero kilometers
Cloud Height	800ft 2200ft 4300ft	Eight hundred feet Two thousand two hundred feet Four thousand three hundred feet
Runway Visual Range	700m 1600m	RVR seven hundred metres RVR one thousand six hundred metres



### Transmission of Time

3.207 When transmitting time, each digit should be pronounced separately. Only the minutes of the hour are normally required. However, the hour should be included if there is any possibility of confusion. (For this reason, transmission of a SARTIME should always include the hour.)

Time	Transmitted As	Pronounced As
0803	ZERO THREE or ZERO EIGHT ZERO THREE	ZE-RO TREE or ZE-RO AIT ZE-RO TREE
1300	ONE THREE ZERO ZERO	WUN TREE ZE-RO ZE-RO
2057	FIVE SEVEN or TWO ZERO FIVE SEVEN	FIFE SEV-en or TOO ZE-RO FIFE SEVen

**Note:** Co-ordinated universal time (UTC) must be used.

3.208 Pilots may check the time with the appropriate ATS unit. Time checks must be given to the nearest half minute.

FASTAIR 345 REQUEST TIME CHECK

FASTAIR 345 TIME 0611  
or  
FASTAIR 345 TIME 0715 AND A HALF



## Standard Words and Phrases

3.209 The following words and phrases must be used in radiotelephony communications as appropriate and when used have the meaning given below.

Word/Phrase	Meaning
<b>ACKNOWLEDGE</b>	Let me know that you have received and understood this message
<b>AFFIRM</b>	Yes
<b>APPROVED</b>	Permission for proposed action granted
<b>BREAK</b>	I hereby indicate the separation between portions of the message (to be used where there is no clear distinction between the text and other portions of the message)
<b>BREAK BREAK</b>	I hereby indicate separation between messages transmitted to different aircraft in a very busy environment
<b>CANCEL</b>	Annul the previously transmitted clearance
<b>CHECK</b>	Examine a system or procedure (Not to be used in any other context. No answer is normally expected.)
<b>CLEARED</b>	Authorised to proceed under the conditions specified
<b>CONFIRM</b>	I request verification of: (clearance, instruction, action, information)
<b>CONTACT</b>	Establish communications with ...
<b>CORRECT</b>	True or Accurate
<b>CORRECTION</b>	An error has been made in this transmission (Or message indicated) the correct version is ...
<b>DISREGARD</b>	Ignore
<b>GO AHEAD</b>	Proceed with your message (Not to be used whenever the possibility exists of misconstruing GO AHEAD as an authorisation for an aircraft to proceed)
<b>HOW DO YOU READ</b>	What is the readability of my transmission?
<b>I SAY AGAIN</b>	I repeat for clarity or emphasis
<b>MAINTAIN</b>	Continue in accordance with the condition(s) specified, or in its literal sense, e.g. "Maintain VFR"
<b>MONITOR</b>	Listen out on (frequency)
<b>NEGATIVE</b>	No or Permission is not granted or That is not correct or Not capable
<b>OVER</b>	My transmission is ended and I expect a response from you (not normally used in VHF communication)
<b>OUT</b>	My transmission is ended and I expect no response from you (not normally used in VHF communication)
<b>READ BACK</b>	Repeat all, or the specified part, of this message back to me exactly as received
<b>RECLEARED</b>	A change has been made to your last clearance and this new clearance supersedes your previous clearance or part thereof
<b>REPORT</b>	Pass me the following information
<b>REQUEST</b>	I should like to know or I wish to obtain
<b>ROGER</b>	I have received all of your last transmission (under NO circumstances to be used in reply to a question requiring READBACK or a direct answer in the affirmative or negative)
<b>SAY AGAIN</b>	Repeat all or the following part of your last transmission
<b>SPEAK SLOWER</b>	Reduce your rate of speech
<b>STANDBY</b>	Wait and I will call you

Word/Phrase	Meaning
UNABLE	I cannot comply with your request, instruction or clearance (normally followed by a reason)
WILCO	I understand your message and will comply with it
WORDS TWICE	a. <b>As a request.</b> Communication is difficult, please send every word or group of words twice. b. <b>As information.</b> Since communication is difficult every word group of words in this message will be sent twice.

## EXCHANGE OF COMMUNICATIONS

### Calling Procedure

3.210 The responsibility of establishing communications rests with the station having traffic to transmit. When establishing communications, an aircraft should use the full callsign of both the aircraft and the aeronautical station. Use of the name of the manufacturer, or of the aircraft model or type, is optional. (Pilots can assess whether aircraft type could be helpful to the recipient for recognition or sequencing purposes).

3.211 After contact has been established, continuous two-way communication is permitted without further identification or callsign until termination of the contact provided no mistake of identity is likely to occur.

3.212 When a ground station wishes to broadcast information, or an aircraft wishes to broadcast information to aircraft in its vicinity, the message should be prefaced by the call "ALL STATIONS".

3.213 No reply is expected to such general calls unless individual stations are subsequently called upon to acknowledge receipt.

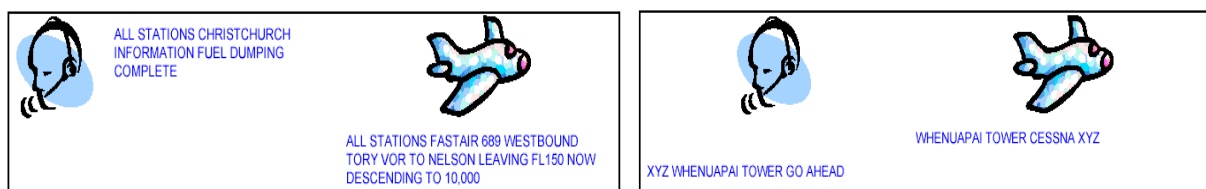

### Readback Requirements

3.214 A pilot is required to acknowledge receipt of the following ATC clearances, information or instructions by **a full readback followed by the aircraft callsign**:

- a. ATC route, approach and departure clearances including any amendment thereof;
- b. Clearances to VFR flights to operate within controlled airspace, including entering or vacating the circuit;
- c. Clearances (including conditional clearances) to operate on the maneuvering area at a controlled aerodrome including:
  - (1) Clearances to land on or take off from the runway-in-use.

- (2) Clearances to enter, cross, or backtrack on the runway-in-use.
  - (3) Instructions to remain on or hold clear of the runway-in-use.
  - (4) Taxi instructions including a taxi route and holding point where specified.
- d. Runway-in-use;
  - e. SSR codes;
  - f. Level instructions;
  - g. Heading and speed instructions;
  - h. Altimeter settings; and
  - i. Frequency, after frequency change instructions.

3.215 **The following exceptions are permitted:** (*Note: in all cases conditional clearances must be read back in full.*)

- a. Aircraft waiting to cross a runway may acknowledge a clearance to cross with the phrase "CROSSING (callsign)"
- b. When a VFR aircraft is cleared by ATC to route via a published arrival or departure procedure that is identical to that **INITIALLY** requested by the pilot, there is no requirement for the pilot to read back the clearance in full. The aircraft must transmit its callsign as an acknowledgment.

3.216 Where a route clearance is passed to another ATS unit or aircraft for relay, the receiver must make a readback to the originator of the clearance.

3.217 ATC, or a relaying aircraft or ATS unit, will acknowledge a correct readback of an ATC route clearance to IFR and VFR aircraft.

3.218 When instructions are received that do not require a full readback they must be acknowledged in a manner which clearly indicates that they have been understood and accepted. "WILCO" will generally suffice in this case.

3.219 Messages that do not require a readback must be acknowledged by the aircraft transmitting its callsign.

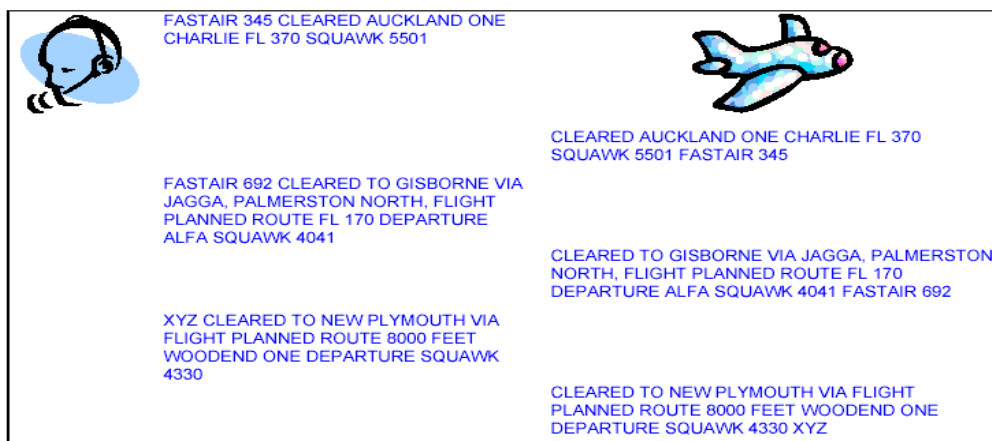

3.220 Where there is difficulty in reading a transmission a readback should be made or requested to verify the content.

### Communication Failure

3.221 When contact with an aeronautical station fails on the selected frequency, the aircraft shall attempt to establish contact on another frequency appropriate to the route.

3.222 If an aircraft is unable to maintain communication with the air – ground control radio station then it is to comply with the “Radio Failure” procedures as prescribed in the New Zealand AIP and the Visual Flight Guide.

### CALLSIGNS

#### Ground Station Callsigns

3.223 Ground stations are identified by the name of the location followed by the service available as follows:

Ground Station	Meaning
<b>CONTROL</b>	Area and approach control, including area and approach radar
<b>APPROACH</b>	Approach control where provided as a separate function
<b>ARRIVAL</b>	Approach control radar arrivals
<b>DEPARTURE</b>	Approach control radar departures
<b>TOWER</b>	Aerodrome control or aerodrome and approach/area control where these services are provided from an aerodrome control tower
<b>GROUND</b>	Surface movement control including clearance delivery
<b>RADAR</b>	Area or approach control radar on a discrete frequency
<b>FLIGHT SERVICE</b>	Aerodrome flight information service (AFIS)
<b>INFORMATION</b>	Area flight information service
<b>DELIVERY</b>	Clearance delivery
<b>RADIO</b>	Air–ground service
<b>UNICOM</b>	UNICOM service

3.224 The name of the location or the service may be omitted provided that satisfactory communication has been established.

## Aircraft Callsigns

3.225 Information on aircraft call-signs for operations within New Zealand are contained in Rule Part 91.

### Domestic Flights

3.226 Civil Aircraft on domestic flights within New Zealand shall be identified by one of the following types of call-signs, using phonetic spelling for the letters of the aircrafts registration marking:

- a. The designator of the aircrafts operating agency followed by the aircrafts flight identification number; or
- b. The designator of the aircrafts operating agency followed by the last three letters of the aircrafts registration marking; or
- c. The type of aircraft followed by the last three letters of the aircrafts registration marking.

3.227 After satisfactory communication has been established and provided no confusion is likely to arise, the call signs shown in (b) and (c) above may be abbreviated to the last three letters of the aircrafts registration marking. No other form of abbreviation of domestic call signs shall be used.

	Type a.	Type b.	Type c.
Full Call Sign	National 531	National BRE	Cessna BSB
Abbreviated Call Sign	No Abbreviation	BRE	BSB

**Note:** Type c. is what you would use in a light aircraft in normal circumstances.

3.228 An aircraft station shall only use its abbreviated callsign after it has been addressed in this manner by the ground station.

3.229 An aircraft callsign does not change during flight except for a temporary period on the instruction of ATC in the interests of safety.



FASTAIR 345 CHANGE YOUR CALLSIGN TO FASTAIR  
ALFA TANGO MIKE

FASTAIR ALFA TANGO MIKE REVERT TO YOUR  
FLIGHT PLAN CALLSIGN AT (TIME/REP)



FASTAIR ALFA TANGO MIKE WILCO

FASTAIR ALFA TANGO MIKE WILCO

## EMERGENCY CALLS

3.230 Emergency calls fall into two categories:

- a. Urgency; and
- b. Distress.

3.231 Transmissions should be made slowly and distinctly with each word being clearly pronounced to ensure they are understood.

3.232 The first call of any Urgency or Distress message should use either **Pan Pan** or **Mayday** respectively repeated three times at the start of the message and maybe repeated in following messages if considered necessary.

### Urgency Calls

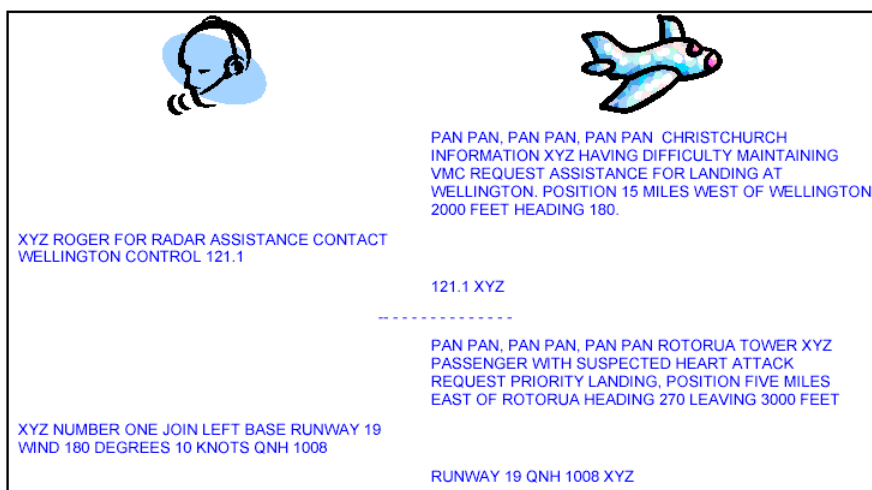

3.233 An urgency call is a call about a condition concerning the safety of an aircraft or other vehicle, or of some person on board or within sight, but which does not require immediate assistance. **Pan Pan** is repeated three times at the start of the message. See example below.



### Distress Calls

3.234 A Distress call is a call about a condition of being threatened by serious and/or imminent danger and of requiring immediate assistance. **Mayday** is repeated three times at the start of the message. See example below.





MAYDAY, MAYDAY, MAYDAY XYZ 20 MILES SOUTH OF OAMARU PASSING 3000 FEET HEADING 360. ENGINE ON FIRE UNABLE TO MAINTAIN HEIGHT MAKING FORCED LANDING.

XYZ DUNEDIN TOWER ROGER MAYDAY

-----

MAYDAY, MAYDAY, MAYDAY GISBORNE TOWER XYZ 10 MILES NORTH OF GISBORNE AT 8000 FEET HEADING 180. ENGINE FAILED WILL ATTEMPT TO LAND AT YOUR FIELD.

XYZ GISBORNE TOWER ROGER MAYDAY CLEARED STRAIGHT-IN RUNWAY 14 WIND 150 DEGREES 10 KNOTS QNH 1008, YOU ARE NUMBER ONE

CLEARED STRAIGHT-IN RUNWAY 14 QNH 1008 XYZ