



NZAP 2.4 Manual of Ceremonial and Drill

Releasable to the public.

©Crown Copyright 2023. This document is the property of the New Zealand Defence Force. The text in this document may be reproduced for use by members of the New Zealand Defence Force. Crown Copyright material must not be used or reproduced for any other purpose without prior permission of the Chief of Defence Force.

UNCLASSIFIED

NZAP 2.4 Manual of Ceremonial and Drill
Authority Order

Version 6.00
13 June 2023

Authority Order

NZAP 2.4 Manual of Ceremonial and Drill

Issued by Assistant Chief of Air Force Training and Support

Authority

1. NZAP 2.4 *Manual of Ceremonial and Drill* is issued and promulgated under the delegated authority of the Deputy Chief of Air Force pursuant to s 27 of the Defence Act 1990 and NZAP 47 *Distribution of Duties* to regulate and administer the delivery of Royal New Zealand Air Force (RNZAF) ceremonial and drill throughout the New Zealand Defence Force (NZDF).
2. The policies, processes and procedures promulgated in this publication are to be applied throughout the NZDF. Any orders, directions or instructions issued by the Services, commands or units must not be inconsistent with those promulgated in this publication.

Conflict

3. Nothing in this publication is to be construed as prevailing over any relevant Act of parliament, or secondary legislation made under it, or any Defence Force Orders, Defence Force Instructions and directives issued and promulgated by the Chief of Defence Force or under their delegated authority.
4. Any conflict between the mandatory requirements stated in this publication and any other policy, order, rule or procedure issued within the NZDF is to be reported to the custodian without delay.

AJ YOUNG

Group Captain

Assistant Chief of Air Force Training and Support

UNCLASSIFIED

NZAP 2.4 Manual of Ceremonial and Drill
Contents

Version 6.00
13 June 2023

Contents

| | |
|--|----------------|
| Authority Order | ii |
| Authority | ii |
| Conflict | ii |
| Preliminary Provisions | 1 |
| Purpose of NZAP 2.4 | 1 |
| Applicability | 1 |
| Releasability | 1 |
| Authorising Authority, Approving Authority and Custodian | 1 |
| Delegation | 1 |
| Amendments | 2 |
| Meaning of terms and abbreviations | 2 |
| Standard of compliance | 2 |
| Statement of equity and inclusion | 3 |
| Authoritative version of the NZAP 2.4 | 3 |
| Related publications | 3 |
| Annex A – Meanings of Terms | 4 |
| PART 1 – FOOT AND WEAPONS DRILL | 1-TOC-1 |
| Chapter 1 – Basic Principles | 1-1 |
| Chapter 2 – Saluting | 1-11 |
| Chapter 3 – Foot Drill | 1-19 |
| Chapter 4 – Marching | 1-34 |
| Chapter 5 – Weapons Drill | 1-46 |
| Chapter 6 – Sword Drill | 1-116 |
| PART 2 – FORMATION DRILL | 2-TOC-1 |
| Chapter 1 – Drill | 2-1 |
| Chapter 2 – Flight Drill | 2-12 |
| Chapter 3 – Squadron Drill | 2-18 |
| Chapter 4 – Squadron Parade Procedure | 2-21 |

UNCLASSIFIED

NZAP 2.4 Manual of Ceremonial and Drill

Version 6.00

Contents

13 June 2023

| | |
|---|----------------|
| Chapter 5 – Wing Drill | 2-38 |
| Chapter 6 – Marching Discipline | 2-54 |
| PART 3 – CEREMONIAL DRILL | 3-TOC-1 |
| Chapter 1 – Ceremonial Drill | 3-1 |
| Chapter 2 – Review of a Flight | 3-7 |
| Chapter 3 – Review of a Squadron | 3-11 |
| Chapter 4 – Review of a Wing | 3-18 |
| Chapter 5 – Service and State Funerals | 3-24 |
| Section 1 – Service funerals | 3-24 |
| Section 2 – State funerals | 3-29 |
| Section 3 – Alternative funeral procedure | 3-34 |
| Section 4 – Memorial service | 3-36 |
| Section 5 – Procession to and arrival at the cemetery | 3-39 |
| Section 6 – Interment service | 3-41 |
| Section 7 – Māori funeral procedure | 3-42 |
| Chapter 6 – Cenotaph Drill | 3-43 |
| Chapter 7 – Guards of Honour | 3-44 |
| Chapter 8 – Royal Guards at Government House | 3-54 |
| Chapter 9 – Quarter Guards | 3-55 |
| Chapter 10 – Route Lining | 3-65 |
| Chapter 11 – Graduation Parade | 3-68 |
| Section 1 – Outdoor parade procedure | 3-69 |
| Section 2 – Wet weather alternative | 3-76 |
| Chapter 12 – Change of Command Parade with the Sovereign’s Colour | 3-81 |
| Section 1 – Outdoor parade procedure | 3-81 |
| Section 2 – Indoor parade procedure | |
| PART 4 – QUEEN’S COLOUR AND SQUADRON STANDARD | |
| CEREMONIAL DRILL | 4-TOC-1 |
| Chapter 1 – The Royal New Zealand Air Force Ensign | 4-1 |
| Chapter 2 – The Queen’s Colour | 4-5 |

UNCLASSIFIED

NZAP 2.4 Manual of Ceremonial and Drill

Version 6.00

Contents

13 June 2023

| | |
|--|-------|
| Chapter 3 – Colour and Standard Drill | 4-9 |
| Chapter 4 – Presentation, Handing Over and Laying-up of Queen’s Colour or Squadron Standard | 4-23 |
| Section 1 – The consecration and presentation of Queen’s Colour or Squadron Standard | 4-23 |
| Section 2 – Ceremony for handing over Queen’s Colour/Squadron Standard. | 4-28 |
| Section 3 – Laying-up of the Queen’s Colour/Squadron Standard | 4-33 |
| Section 4 – Alternative procedure for the ceremony of parading the Queens Colour/Squadron Standard | 4-35 |
| Chapter 5 – King’s Birthday Parade with Queen’s Colour Handover | 4-39 |
| Section 1 – Outdoor parade procedures. | 4-39 |
| Section 2 – Alternative Procedures for the Queen’s Colour handover parade | 4-53 |
| Chapter 6 – Squadron Standards | 4-62 |
| Chapter 7 – Presentation of a Squadron Standard | 4-65 |
| Chapter 8 – King’s Birthday Parade without Queen’s Colour. | 4-82 |
| Chapter 9 – Parading the Queen’s Colour on His Majesty’s Official Birthday with Support Squadrons | 4-87 |
| Section 1 – Support squadrons armed | 4-87 |
| Section 2 – Support squadrons unarmed | 4-97 |
| Chapter 10 – Freedom of Entry to a City or Town. | 4-98 |
| Chapter 11 – Beating Retreat | 4-105 |
| Chapter 12 – RNZAF Commemorative Service, Wellington Cathedral of St Paul | 4-112 |
| End Matter | EM-1 |
| Amendment Certificate | EM-1 |

UNCLASSIFIED

NZAP 2.4 Manual of Ceremonial and Drill
Preliminary Provisions

Version 6.00
13 June 2023

Preliminary Provisions

Purpose of NZAP 2.4

1. The purpose of NZAP 2.4 *Manual of Ceremonial and Drill* is to provide the drill and ceremonial standards for Royal New Zealand Air Force (RNZAF) personnel responsible for the delivery of drill and ceremonial requirements.

Applicability

2. The directions and instructions in this publication constitute—
 - a. general orders to all members of the Armed Forces; and
 - b. lawful and reasonable instructions to—
 - (1) members of the Civil Staff; and
 - (2) contractors and their employees engaged by the New Zealand Defence Force (NZDF).

Releasability

3. NZAP 2.4 is available on the NZDF intranet and may be released to third parties following approval from the Approving Officer.

Authorising Authority, Approving Authority and Custodian

4. The Authorising Authority for NZAP 2.4 is Assistant Chief of Air Force Training and Support (ACAF T&S).
5. The Approving Authority for NZAP 2.4 is Assistant Director Corporate Support, Training and Support (ADCS T&S).
6. The Custodian of NZAP 2.4 is Warrant Officer Ceremonial Protocol and Events (W/O CP&E), Air Staff.

Delegation

7. Pursuant to s 27(2) of the Defence Act 1990, ACAF T&S is authorised to approve, issue and promulgate amendments to NZAP 2.4 that do not
 - a. effect a significant change to NZDF policy or conditions of service;
 - b. affect legal matters, occupational health and safety or the reputation of the NZDF; or
 - c. affect financial matters.

UNCLASSIFIED

NZAP 2.4 Manual of Ceremonial and Drill
Preliminary Provisions

Version 6.00
13 June 2023

Amendments

8. Users of NZAP 2.4 are to bring to the notice of the Custodian details of any errors or other necessary amendments.
9. Users of NZAP 2.4 are to advise Air Staff, Headquarters New Zealand Defence Force (HQNZDF) where instructions in this manual are in conflict with [AFGO](#) *Air Force General Orders* or any other superior authority.
10. Routine amendments are to be submitted via Publication Amendment Information using a Form [RNZAF852](#).
11. A record of amendments, current and historical, is maintained in the Record of Change in the End Matter.

Meaning of terms and abbreviations

12. NZAP 2.4 is aligned 'so far as is reasonably practicable' with definitions and interpretations specified in DFI 113 *Visits, Ceremonial and Protocol* (TBI) and publications listed in the related publications section of these Preliminary Provisions.
13. A list of abbreviations, acronyms and contractions used in NZAP 2.4 is provided in Annex A to these Preliminary Provisions.

Standard of compliance

14. The information in NZAP 2.4 is consistent with—
 - a. relevant legislation;
 - b. DFI 113 (TBI); and
 - c. [AFGO](#).
15. In NZAP 2.4 the terms 'must' and 'should' are used as follows—
 - a. 'Must' means compliance is mandatory under—
 - (1) Any direction published in this manual.
 - (2) Any authorised technique, tactic or procedure published subordinate to this publication.
 - b. 'Should' means the action is recommended as good practice, but compliance is not mandatory, therefore—
 - (1) following the recommendation is enough to comply with the law, but there may be an alternative action that meets the NZDF's required standard;
 - (2) taking an alternative action is not an offence, but it must first be demonstrated that the action is of a standard equivalent to or higher than that required by the NZDF; and/or

UNCLASSIFIED

NZAP 2.4 Manual of Ceremonial and Drill
Preliminary Provisions

Version 6.00
13 June 2023

- (3) where an alternative action that has been taken does not meet the standard required by the NZDF, this may result in enforcement action for breach of a lawful command or written order.

Statement of equity and inclusion

16. The content and tone of NZAP 2.4 is non-discriminatory and non-prejudicial. Every effort has been made, so far as practicable, to ensure that there is no disproportionate impact on gender, ethnicity, age, diversity or disabilities unless the expression is relevant to an order, direction or instruction.

Authoritative version of the NZAP 2.4

17. The online copy of NZAP 2.4 is the authoritative version. Any printed copy is deemed uncontrolled and is to be used for guidance only.
18. Every page of this online publication displays Version 6.00 dated 13 June 2023. This is the status of the publication.

Related publications

19. The following legislation, regulations and publications are applicable to NZAP 2.4—
- A. DFI 113 *Visits, Ceremonial and Protocol* (TBI)
 - B. [AFGO](#) *Air Force General Orders*
 - C. [NZAP 3327](#) *Colours, Standards, Flags and Badges in the Royal New Zealand Air Force*
 - D. [NZAP 207](#) *Royal New Zealand Air Force Dress Instructions*
 - E. [NZ P6](#) *Drill Manual*
 - F. [NZ P6A](#) *NZ Army Ceremonial*
 - G. [NZBR 033](#) *RNZN Flag Ceremonial Procedures Manual*

UNCLASSIFIED

NZAP 2.4 Manual of Ceremonial and Drill
Preliminary Provisions

Version 6.00
13 June 2023

Annex A**Meanings of Terms**

1. Words and phrases are to be given their ordinary grammatical or military meaning as described in relevant legislation, military glossaries and authorised dictionaries.
2. Meanings of terms used in this publication that are not explained in authorised reference documents or that are not in common use are listed in this abbreviations list.

| Term | Definition |
|-------------|---|
| ACAF T&S | Assistant Chief of Air Force Training and Support |
| ACC | Air Component Commander |
| ADCS T&S | Assistant Director Corporate Support Training and Support |
| ADJ | adjutant |
| ADO | assistant duty officer |
| AIR CDRE | Air Commodore |
| BCDR | Base Commander |
| BPIC | bearerparty in charge |
| CAF | Chief of Air Force |
| CoS | Chief of Staff |
| CPL | corporal |
| DNCO | duty non-commissioned officer |
| DO | duty officer |
| ESADJ | escort squadron adjutant |
| ESCDR | escort squadron commander |
| ESWO | escort squadron warrant officer |
| FLTCDR | flight commander |
| FLTLT | flight lieutenant |
| F/S | flight sergeant |
| GCDR | guard commander |
| HCP | Heritage, Commemoration and Protocol Group |
| JR | junior rank |
| MARS-L | Modular Assault Rifle System - Light |
| MCG | Māori Cultural Group |
| NCO | non-commissioned officer |
| NCOIC | non-commissioned officer in charge |
| NCR | non-commissioned ranks |
| NOK | next-of-kin |
| NZA | New Zealand Army |
| NZDF | New Zealand Defence Force |
| OO | orderly officer |
| OR | Other ranks |
| PCDR | parade commander |

UNCLASSIFIED

NZAP 2.4 Manual of Ceremonial and Drill
Preliminary Provisions

Version 6.00
13 June 2023

| | |
|----------|--|
| QC | Queen's Colour |
| QC/SqnS | Queen's Colour/Squadron Standard |
| QCB | Queen's Colour bearer |
| QCO | Queen's Colour orderly |
| QCP | Queen's Colour party |
| QCWO | Queen's Colour warrant officer |
| RNZAF | Royal New Zealand Air Force |
| RNZN | Royal New Zealand Navy |
| SADJ | squadron adjutant |
| SD | service dress |
| SGT | sergeant |
| SNCO | senior non-commissioned officer |
| SCDR | squadron commander |
| SQNLDR | squadron leader |
| SqnS | Squadron Standard |
| SqnSB | Squadron Standard bearer |
| SqnSP | Squadron Standard party |
| SSqnCDR | support squadron commander |
| SWO | squadron warrant officer |
| TBI | to be issued |
| VIP | very important persons |
| VVIP | very, very important persons |
| WADJ | wing adjutant |
| W/O | Warrant Officer |
| W/O CP&E | Warrant Officer Ceremonial Protocol and Events |
| WOS | wing orderly sergeant |
| WWO | wing warrant officer |

PART 1 – FOOT AND WEAPONS DRILL

Contents

| | |
|--|-------------|
| Chapter 1 – Basic Principles | 1-1 |
| 1.1.1 Purpose of NZAP 2.4 | 1-1 |
| 1.1.2 Method of instruction | 1-1 |
| 1.1.3 Sequence of training | 1-2 |
| 1.1.4 Words of command | 1-3 |
| 1.1.5 Calling the time for drill movements | 1-5 |
| 1.1.6 Drill timings | 1-5 |
| Table 1-1-1 Executive Command Given When on the Move | 1-5 |
| Table 1-1-2 Timings for Foot Drill at the Halt | 1-6 |
| Table 1-1-3 Timings for Foot Drill on the March | 1-6 |
| Table 1-1-4 Timings for Rifle Drill at the Halt | 1-7 |
| Table 1-1-5 Timings for Sword Drill | 1-7 |
| Table 1-1-6 Forming a Hollow Square | 1-8 |
| 1.1.7 Numbering | 1-9 |
| 1.1.8 Intervals | 1-10 |
| 1.1.9 Distance | 1-10 |
| 1.1.10 Length of pace in marching | 1-10 |
| 1.1.11 Time in marching | 1-10 |
| Table 1-1-7 The Length of Pace in Marching | 1-10 |
| Table 1-1-8 Marching Rates | 1-10 |
| Chapter 2 – Saluting | 1-11 |
| 1.2.1 Reason for saluting | 1-11 |
| 1.2.2 Instructions for saluting | 1-11 |
| 1.2.3 Officers saluting without weapons | 1-11 |
| 1.2.4 Officers saluting when on an armed parade | 1-12 |
| 1.2.5 ORs saluting with and without weapons | 1-12 |

UNCLASSIFIED

NZAP 2.4 Manual of Ceremonial and Drill

Version 6.00

Part 1 – Foot and Weapons Drill

13 June 2023

Contents

| | | |
|---|--|-------------|
| 1.2.6 | Officer cadets and Air Force cadets | 1-13 |
| 1.2.7 | Trumpeters and buglers | 1-13 |
| 1.2.8 | Compliments paid when in civilian attire | 1-13 |
| 1.2.9 | Compliments paid during a national anthem | 1-13 |
| 1.2.10 | Raising/lowering of the RNZAF Ensign | 1-14 |
| 1.2.11 | Guard salutes. | 1-14 |
| 1.2.12 | Funerals | 1-14 |
| 1.2.13 | Passing troops or naval landing parties with uncased Sovereigns Colours or Squadron Standards | 1-14 |
| 1.2.14 | Boarding or leaving Their Majesty's ships. | 1-14 |
| 1.2.15 | Mechanical or electrical vehicles. | 1-14 |
| 1.2.16 | Parties on the march. | 1-15 |
| 1.2.17 | Compliments with the sword. | 1-15 |
| 1.2.18 | Bicycles. | 1-15 |
| 1.2.19 | Within buildings and offices. | 1-15 |
| 1.2.20 | Warrant officers | 1-15 |
| 1.2.21 | Saluting on ceremonial parades. | 1-15 |
| 1.2.22 | Further information on compliments | 1-16 |
| 1.2.23 | Saluting at the halt and on the march. | 1-16 |
| 1.2.24 | Saluting to the right/left at the halt. | 1-17 |
| 1.2.25 | Saluting on the march in quick time | 1-17 |
| 1.2.26 | Eyes right/left/front | 1-18 |
| 1.2.27 | Officers. | 1-18 |
| Chapter 3 – Foot Drill | | 1-19 |
| 1.3.1 | General. | 1-19 |
| 1.3.2 | Timing | 1-19 |
| 1.3.3 | Formation of a flight | 1-19 |
| | Table 1-3-1 Foot Drill Timings | 1-20 |
| 1.3.4 | Blank files. | 1-20 |
| 1.3.5 | Open and close order | 1-20 |

UNCLASSIFIED

NZAP 2.4 Manual of Ceremonial and Drill
 Part 1 – Foot and Weapons Drill
 Contents

Version 6.00
 13 June 2023

| | | |
|-----------------------------------|--|-------------|
| 1.3.6 | Open and close order march | 1-21 |
| 1.3.7 | Dressing | 1-21 |
| 1.3.8 | Dressing without intervals | 1-22 |
| 1.3.9 | Attention, stand at ease, stand easy | 1-22 |
| | Figure 1-3-1 Position of Attention | 1-23 |
| | Figure 1-3-2 The Position of Stand at Ease | 1-25 |
| 1.3.10 | Turns at the halt | 1-26 |
| | Figure 1-3-3 1st Position for Left Turn at the Halt | 1-27 |
| 1.3.11 | Inclining to the right/left | 1-27 |
| 1.3.12 | Turning about | 1-28 |
| | Figure 1-3-4 1st Position for About Turn | 1-28 |
| 1.3.13 | Saluting to the front when halted | 1-29 |
| | Figure 1-3-5 Position for Saluting to the Front when Halted | 1-30 |
| 1.3.14 | Saluting to the right/left at the halt | 1-30 |
| | Figure 1-3-6 Saluting to the Right and to the Left at the Halt | 1-31 |
| 1.3.15 | Saluting on the march in quick time | 1-31 |
| 1.3.16 | Eyes right/left and eyes front | 1-32 |
| 1.3.17 | Officers | 1-33 |
| Chapter 4 – Marching | | 1-34 |
| 1.4.1 | Quick march | 1-34 |
| 1.4.2 | Mark time | 1-34 |
| 1.4.3 | Variation in pace | 1-35 |
| 1.4.4 | Turnings on the march | 1-35 |
| 1.4.5 | Moving forward or backward a given number of paces | 1-35 |
| 1.4.6 | Moving sideways a given number of paces | 1-36 |
| 1.4.7 | Quick march to slow march | 1-36 |
| 1.4.8 | Slow march to quick march | 1-37 |
| 1.4.9 | Marching in double time | 1-37 |
| 1.4.10 | Changing from quick time to double time | 1-38 |

UNCLASSIFIED

NZAP 2.4 Manual of Ceremonial and Drill
 Part 1 – Foot and Weapons Drill
 Contents

Version 6.00
 13 June 2023

| | | |
|---------------------------------------|--|-------------|
| 1.4.11 | Changing from double time to quick time | 1-38 |
| 1.4.12 | Marching in slow time | 1-39 |
| Figure 1-4-1 | Position for the Balance Step | 1-39 |
| Figure 1-4-2 | Position when Marking Time | 1-42 |
| Figure 1-4-3 | Position for Block Pace on Right Turn on the March | 1-44 |
| Table 1-4-1 | Length of Pace in Marching | 1-45 |
| Chapter 5 – Weapons Drill..... | | 1-46 |
| 1.5.1 | Method of instruction..... | 1-46 |
| 1.5.2 | Armed parades | 1-46 |
| 1.5.3 | Position when carrying weapons..... | 1-46 |
| 1.5.4 | Rifle positions | 1-47 |
| Figure 1-5-1 | Position of Attention | 1-47 |
| Figure 1-5-2 | 1st Position of Stand at Ease..... | 1-48 |
| Figure 1-5-3 | 2nd Position of Stand at Ease..... | 1-49 |
| Figure 1-5-4 | 3rd Position of Stand at Ease | 1-50 |
| Figure 1-5-5 | 1st Position of Shoulder Arms | 1-51 |
| Figure 1-5-6 | 2nd position of Shoulder Arms..... | 1-52 |
| 1.5.5 | Salute at the shoulder arms | 1-52 |
| Figure 1-5-7 | Position of Saluting to the Front..... | 1-53 |
| 1.5.6 | Present arms from the shoulder arms..... | 1-54 |
| Figure 1-5-8 | 1st Position of the Present from the Shoulder | 1-55 |
| Figure 1-5-9 | 2nd Position of the Present from the Shoulder | 1-56 |
| 1.5.7 | Shoulder arms from the present arms | 1-56 |
| 1.5.8 | Ground arms, take up arms and change arms | 1-57 |
| Figure 1-5-10 | 1st Position of the Ground Arms | 1-58 |
| Figure 1-5-11 | 2nd Position of the Ground Arms | 1-59 |
| Figure 1-5-12 | 3rd Position of the Ground Arms..... | 1-60 |
| Figure 1-5-13 | 4th Position of the Ground Arms..... | 1-61 |
| Figure 1-5-14 | 1st Position of the Take Up Arms..... | 1-62 |

UNCLASSIFIED

NZAP 2.4 Manual of Ceremonial and Drill
 Part 1 – Foot and Weapons Drill
 Contents

Version 6.00
 13 June 2023

| | | |
|---------------|--|------|
| Figure 1-5-15 | 2nd Position of the Take Up Arms | 1-63 |
| Figure 1-5-16 | 3rd Position of the Take Up Arms. | 1-64 |
| Figure 1-5-17 | 4th Position of the take Up Arms. | 1-65 |
| Figure 1-5-18 | 1st Position of the Change Arms at the Halt | 1-66 |
| Figure 1-5-19 | 2nd Position of the Change Arms at the Halt | 1-67 |
| Figure 1-5-20 | 3rd Position of the Change Arms at the Halt. | 1-68 |
| Figure 1-5-21 | 4th Position of the Change Arms at the Halt. | 1-69 |
| 1.5.9 | Fix and unfix bayonets | 1-69 |
| 1.5.10 | On guard drill for QC/SqnS parties | 1-71 |
| Figure 1-5-22 | Final position of the On Guard Position. | 1-73 |
| 1.5.11 | Rifle drill for funerals | 1-74 |
| 1.5.12 | Reverse arms from the shoulder arms | 1-74 |
| Figure 1-5-23 | 1st Position of the Reverse Arms | 1-75 |
| Figure 1-5-24 | 2nd Position of the Reverse Arms | 1-76 |
| Figure 1-5-25 | 3rd Position of the Reverse Arms. | 1-77 |
| 1.5.13 | Shoulder arms from reverse arms | 1-77 |
| Figure 1-5-26 | 1st Position of the Shoulder Arms from the Reverse Arms . . . | 1-78 |
| Figure 1-5-27 | 2nd Position of the Shoulder Arms from the Reverse Arms . . | 1-79 |
| Figure 1-5-28 | 3rd Position of the Shoulder Arms from the Reverse Arms . . . | 1-80 |
| 1.5.14 | Present arms from reverse arms | 1-80 |
| Figure 1-5-29 | 1st Position of the Present Arms from the Reverse Arms | 1-81 |
| Figure 1-5-30 | 2nd Position of the Present Arms from the Reverse Arms. . . . | 1-82 |
| 1.5.15 | Change arms from reverse arms | 1-82 |
| Figure 1-5-31 | 1st Positions of the Change Arms at the Reverse | 1-83 |
| Figure 1-5-32 | 2nd Position of the Change Arms at the Reverse | 1-84 |
| 1.5.16 | Lower on arms reverse from reverse arms | 1-84 |
| Figure 1-5-33 | 1st Position of the Lower on Arms Reverse from the Reverse Arms | 1-85 |
| Figure 1-5-34 | 2nd Position of the Lower on Arms Reverse from the Reverse Arms | 1-86 |

| | | |
|--------|---|-------|
| 1.5.17 | Reverse arms from lower on arms reverse | 1-86 |
| | Figure 1-5-35 1st Position of the Reverse Arms from the Lower On Arms Reverse | 1-87 |
| | Figure 1-5-36 2nd Position of the Reverse Arms from the Lower On Arms Reverse | 1-88 |
| 1.5.18 | Shoulder Arms from Lower On Arms Reverse | 1-88 |
| | Figure 1-5-37 1st Position of the Shoulder Arms from the Lower On Arms Reverse | 1-89 |
| | Figure 1-5-38 2nd Position of the Shoulder Arms from the Lower On Arms Reverse | 1-90 |
| | Figure 1-5-39 3rd Position of the Shoulder Arms from the Lower On Arms Reverse | 1-91 |
| 1.5.19 | Present arms from the lower on arms reverse | 1-91 |
| | Figure 1-5-40 1st Position of the Present Arms from the Lower On Arms Reverse | 1-92 |
| | Figure 1-5-41 2nd Position of the Present Arms from he Lower On Arms Reverse | 1-93 |
| 1.5.20 | Lower on arms reverse from the present arms | 1-93 |
| | Figure 1-5-42 1st Position of the Lower on Arms Reverse from the Present | 1-94 |
| | Figure 1-5-43 2nd Position of the Lower on Arms Reverse from the Present | 1-95 |
| | Figure 1-5-44 3rd Position of the Present from the Lower On Arms Reverse | 1-96 |
| | Figure 1-5-45 4th Position of the Present from the Lower On Arms Reverse | 1-97 |
| 1.5.21 | Lower on arms reverse from the shoulder arms | 1-97 |
| | Figure 1-5-46 1st Position of the Lower On Arms from the Shoulder Arms | 1-98 |
| | Figure 1-5-47 3rd Position of the Lower On Arms from the Shoulder Arms | 1-99 |
| | Figure 1-5-48 4th Position of the Lower On Arms from the Shoulder Arms | 1-100 |
| | Figure 1-5-49 5th Position of the Lower On Arms from the Shoulder Arms | 1-101 |

UNCLASSIFIED

NZAP 2.4 Manual of Ceremonial and Drill
 Part 1 – Foot and Weapons Drill
 Contents

Version 6.00
 13 June 2023

| | | |
|--------------------------------------|---|--------------|
| 1.5.22 | Change arms at the lower on arms reverse | 1-101 |
| 1.5.23 | Breaking into quick time from slow march at the reverse arms and halting in quick time at the reverse | 1-102 |
| 1.5.24 | Firing volleys | 1-103 |
| Figure 1-5-50 | 1st Position of the Firing of Volleys | 1-103 |
| Figure 1-5-51 | 2nd Position of the Firing of Volleys | 1-104 |
| Figure 1-5-52 | 3rd Position of the Firing of Volleys | 1-105 |
| Figure 1-5-53 | 4th Position of the Firing of Volleys | 1-106 |
| Figure 1-5-54 | 5th Position of the Firing of Volleys | 1-107 |
| Figure 1-5-55 | 6th Position of the Firing of Volleys | 1-108 |
| Figure 1-5-56 | 7th Position of the Firing of Volleys | 1-109 |
| Figure 1-5-57 | 8th Position of the Firing of Volleys | 1-110 |
| Figure 1-5-58 | 9th Position of the Firing of Volleys | 1-111 |
| Figure 1-5-59 | 10th Position of the Firing of Volleys | 1-113 |
| Figure 1-5-60 | 11th Position of the Firing of Volleys | 1-114 |
| Figure 1-5-61 | 12th Position of the Firing of Volleys | 1-115 |
| Chapter 6 – Sword Drill | | 1-116 |
| 1.6.1 | General | 1-116 |
| 1.6.2 | Warrant officers | 1-117 |
| 1.6.3 | Method of wearing the sword | 1-117 |
| 1.6.4 | Sword care and maintenance | 1-117 |
| 1.6.5 | Positions of attention and standing at ease/easy and draw/return swords | 1-118 |
| Figure 1-6-1 | The Position of Attention While Wearing a Sword | 1-119 |
| Figure 1-6-2 | The Position of Attention While Wearing a Sword | 1-119 |
| Figure 1-6-3 | The Position of Stand at Ease While Wearing a Sword | 1-120 |
| Figure 1-6-4 | 1st Position of the Draw Swords | 1-121 |
| Figure 1-6-5 | 2nd Position of the Draw Swords - The Recover | 1-122 |
| Figure 1-6-6 | 3rd Position of the Draw Swords – The Carry | 1-123 |
| Figure 1-6-7 | The Position of Stand at Ease with Sword Drawn | 1-124 |

| | | |
|---------------|---|-------|
| Figure 1-6-8 | The Position of Standing Easy with Sword Drawn | 1-125 |
| Figure 1-6-9 | The Position of Standing at Ease with Sword Drawn | 1-126 |
| Figure 1-6-10 | 1st Position of the Return Swords | 1-127 |
| Figure 1-6-11 | 2nd Position of the Return Swords | 1-128 |
| Figure 1-6-12 | 3rd Position of the Return Swords | 1-129 |
| 1.6.6 | Saluting with the sword at the halt | 1-129 |
| Figure 1-6-13 | The Salute Position | 1-130 |
| Figure 1-6-14 | The Salute with the Sword Position at the Halt | 1-131 |
| 1.6.7 | The brief salute | 1-131 |
| Figure 1-6-15 | The Brief Salute | 1-132 |
| 1.6.8 | Saluting from the carry when marching past | 1-132 |
| Figure 1-6-16 | 1st Position of Saluting on the March | 1-133 |
| Figure 1-6-17 | 2nd Position of Saluting on the March | 1-134 |
| 1.6.9 | The carry from the salute | 1-134 |
| Figure 1-6-18 | 1st Position of the Carry from the Salute | 1-135 |
| Figure 1-6-19 | 2nd Position of the Carry from the Salute | 1-136 |
| 1.6.10 | Dismissing with the sword | 1-136 |
| 1.6.11 | The slung position | 1-137 |
| Figure 1-6-20 | Position of Attention in the Slung Position | 1-137 |
| Figure 1-6-21 | Position of Ease in the Slung Position | 1-138 |
| Figure 1-6-22 | Position Ready to Quick March in the Slung Position | 1-139 |
| Figure 1-6-23 | Position of Attention in the Halt Position | 1-140 |
| 1.6.12 | Wearing the sword at levees | 1-140 |

Chapter 1 – Basic Principles

1.1.1 Purpose of NZAP 2.4

- a. NZAP 2.4 *Manual of Drill and Ceremonial* sets out the correct procedures for drill and ceremonial requirements for the Royal New Zealand Air Force (RNZAF). Drill movements that are to be taught in the Service are laid down in this manual.

Note: The ceremonial drills in Part 3 and Part 4 are for guidance purposes. They may be adjusted to fit different locations and to serve the specific requirements of different ceremonial events.

- b. Where an RNZAF formation is required to integrate into a tri-Service guard, agreement will be reached between single Service ceremonial warrant officers (W/Os) and the NZDF Ceremonial Warrant Officer on a common format. The content of this manual has been amended to reflect common drill across the Services to mitigate the need for two standards of drill and therefore, extended training periods.

1.1.2 Method of instruction

- a. The full value of drill depends on the way in which it is carried out; therefore the instructor or parade commander (PCDR) is to insist on—
- (1) immediate obedience to orders;
 - (2) absolute cleanliness and correctness of all other ranks (ORs) including their—
 - (a) clothing;
 - (b) arms; and
 - (c) equipment;
 - (3) alertness, concentration, steadiness and smartness of all individuals; and
 - (4) silence during parades.
- b. The instructor, by personal example, is to be a model to others and must therefore—
- (1) know the subject well;
 - (2) be patient, yet firm;
 - (3) be able to pick out those ORs who are quick to learn, so that the slower learners can be given individual instruction and encouragement;
 - (4) know, and be sympathetic to, those under their control; and
 - (5) be alert and smart.

- c. Instruction is to—
- (1) be simple, concise, consistent and interesting, so that drills are easily learnt and remembered;
 - (2) be with the same instructor, if possible, carrying out the complete sequence of training for a particular squad so that all ORs can receive the maximum amount of personal supervision;
 - (3) have periods of instruction that are short, to avoid the instructor and/or trainees becoming over-tired;
 - (4) be conducted with the flight stood easy when the instructor is explaining the details of a movement; and
 - (5) be supported by a programme that is varied to avoid monotony and consequent loss of interest.

1.1.3 Sequence of training

- a. The following sequence is to be adopted—
- (1) The instructor is to—
 - (a) name the exercise;
 - (b) demonstrate the movement; and
 - (c) explain the movement, stating in simple language the relevant details.
 - (2) ORs are to carry out the exercise by individual practice and then by numbers.
 - (3) Individual faults are to be corrected by the instructor.
 - (4) ORs are to practice the movement to proficiency.
 - (5) After improvement, ORs are to carry out the movement in quick time, judging the time.
 - (6) During the initial period of instruction, when teaching movements by numbers, the procedure at paragraph 1.1.3a.(7) is to be adopted by all instructors.
 - (7) The actual word of command is to be given, followed by the words 'By Numbers' and the executive words of command (refer to paragraph [1.1.4d.](#)—

RIGHT TURN

BY NUMBERS – ONE

BY NUMBERS – TWO

- (8) As the efficiency of the RNZAF depends mainly upon the individual efficiency of each member of the Service, drill training is to be both individual and collective.

- b. Drill instruction is to be divided into the following progressive stages—
- (1) **Foot drill.** Foot drill is designed to train members of the Service—
 - (a) in obedience, steadiness, self-reliance and alertness;
 - (b) to understand an order instantly;
 - (c) to be smart; and
 - (d) to become accustomed as individuals to take their place in a disciplined body.
 - (2) **Rifle drill.** Rifle drill is designed to teach individuals how to carry and use rifles on parade.
 - (3) **Drill movements in formation.** Drill movements in formation enable large numbers of ORs to be controlled effectively by their commanders. Practice in these movements develops a high standard of individual discipline and a mutual confidence between all ranks in a unit.

1.1.4 Words of command

- a. Given that words of command convey an order that is to be smartly and promptly obeyed, they are to be given—
- (1) distinctly, with confidence and determination;
 - (2) loudly enough to be heard by all concerned; and
 - (3) with sufficient interval observed to allow the order to carry over the distance between the instructor and all personnel.
- b. Those responsible for giving orders are to be given frequent practice in delivering words of command to increase their confidence.
- c. A person giving an order is to stand to attention.
- d. Words of command can be classified in three ways. These are precautionary, cautionary and executive words of command—
- (1) A precautionary word of command explains the movement that is to be carried out, however not every command sequence contains a precautionary.
 - (2) A cautionary word of command should always be given as it gives warning that an executive follows.
 - (3) The precautionary and cautionary are given deliberately and distinctly.
 - (4) The executive is the signal to carry out the movement. It is normally a word of one syllable given distinctly and sharply in a different, higher pitch.
 - (5) The voice must not be lowered or taper off.

- (6) There is always to be a pause between the cautionary and executive words of command. For example—
- MOVE TO THE RIGHT IN THREES** (precautionary)
RIGHT (cautionary)
TURN (executive)
- and
- FLIGHT** (cautionary)
HALT (executive)
- e. For uniformity, the pause between the cautionary and executive words of command is to conform to the following—
- (1) It is to be equivalent to two beats in the cadence of slow or quick time, depending on whether the movements are to be made in slow or quick time.
 - (2) When a squad is moving in slow time, the last word of the cautionary is to be given as one foot touches the ground; this is to be followed by a pause while the other foot completes its pace.
 - (3) The executive word is to be given as the first foot again touches the ground.
 - (4) If a squad is halted, the pause between the cautionary and the executive words of command is still to be made.
- f. When an order is given to ORs on the march, the executive word of command is to be given one pace before the movement is to be made so as to give the individual time to control the forward movement before carrying it out. This pace is called the 'check pace' and its use is described as follows—
- (1) The cautionary word 'RIGHT' is to be given when the left foot is forward and on the ground.
 - (2) The executive word 'TURN' is to be given when the left foot is again forward and on the ground.
 - (3) Individuals check their momentum on the next pace forward by the right foot and carry out the turn with the left foot.
- g. To move a unit off in step with a preceding unit, in quick or slow time, the cautionary word 'QUICK/SLOW' is to be given when the right feet of ORs in the preceding unit are forward and on the ground, followed by the executive word 'MARCH' when the right feet of ORs in the preceding unit are again forward and on the ground.
- h. The cautions and commands in this manual are normally given with regard to one flank only, but the principles apply equally to movements of the other flank, which are also to be practiced.
- i. A command given from a distance is to be delivered early enough to allow for the increased time it will take for the voice to reach the squad.

- j. The initial word of command is normally to be prefixed with the title of the unit to which the command is being given, for example—

NO ___ FLIGHT

RIGHT TURN

NO ___ SQUADRON

RIGHT TURN

NO ___ WING

RIGHT TURN

1.1.5 Calling the time for drill movements

- a. To enable uniformity, a standardised series of timings for drill movements is necessary. When teaching drill movements, the call out is to be used on the demonstration and repeated in any subsequent demonstrations. Foot and arms drill movements are to be carried out at the rate of 60 drill movements per minute (using the call out ONE, LEFT – RIGHT, TWO).
- b. Table [1-1-1](#) details the foot on which the executive word of command is to be given to personnel on the move.

1.1.6 Drill timings

- a. Timings for foot drill at the halt are listed in Table [1-1-2](#).
- b. Timings for foot drill on the march are listed in Table [1-1-3](#).
- c. Timings for rifle drill at the halt are listed in Table [1-1-4](#).
- d. Timings for sword drill are listed in Table [1-1-5](#).

Table 1-1-1 Executive Command Given When on the Move

| Word(s) of Command | Quick Time and Slow Time |
|---|--|
| HALT | When the right foot is forward and on the ground |
| ABOUT - TURN | When the left foot is forward and on the ground |
| RIGHT - TURN | When the left foot is forward and on the ground |
| RIGHT IN - CLINE | When the left foot is forward and on the ground |
| LEFT - TURN | When the right foot is forward and on the ground |
| LEFT IN - CLINE | When the right foot is forward and on the ground |
| MARK - TIME | When the left foot is forward and on the ground |
| HALT (MARKING TIME) | When the right foot is forward and on the ground |
| FORWARD (MARKING TIME) | When the left foot is forward and on the ground |
| CHANGE - STEP (MARKING TIME) | When the right foot is forward and on the ground |
| STEP - OUT | When the left foot is forward and on the ground |
| SLOW/QUICK - MARCH | When the left foot is forward and on the ground |
| STEP - SHORT | When the right foot is forward and on the ground |
| INTO SLOW TIME SLOW - MARCH (WHEN MARCHING IN QUICK TIME) | When the right foot is forward and on the ground |

UNCLASSIFIED

NZAP 2.4 Manual of Ceremonial and Drill
 Part 1 – Foot and Weapons Drill
 Chapter 1 – Basic Principles

Version 6.00
 13 June 2023

| Word of Command | Quick Time and Slow Time |
|---|--|
| INTO QUICK TIME, QUICK - MARCH (WHEN MARCHING IN SLOW TIME) | When the right foot is forward and on the ground |
| INTO DOUBLE TIME, DOUBLE MARCH | When the left foot is forward and on the ground |
| INTO QUICK TIME, QUICK MARCH (FROM THE DOUBLE MARCH) | When the left foot is forward and on the ground |
| HALT (IN DOUBLE TIME) | When the right foot is forward and on the ground |

Table 1-1-2 Timings for Foot Drill at the Halt

| Command | Timing |
|--|--|
| ATTENTION, STAND AT EASE | ONE |
| FLIGHT (BRACE UP) | ONE |
| IN OPEN/CLOSE ORDER RIGHT DRESS | ONE TWO - ONE TWO |
| PACES FORWARD/REAR EG 3 PACES FORWARD | ONE TWO - ONE TWO |
| RIGHT DRESS (PLUS WITHOUT INTERVALS) | UP - LEFT RIGHT - MOVE |
| SIDEWAYS MARCH | ONE TWO ETC |
| TURNS/INCLINES AT THE HALT | ONE - LEFT RIGHT - TWO |
| SALUTING AT THE HALT | UP - LEFT RIGHT - DOWN |
| DISMISS | ONE - LEFT RIGHT - TWO - LEFT RIGHT - 1, 2, 3 |
| OFFICER ON PARADE, DISMISS | ONE - LEFT RIGHT - TWO - LEFT RIGHT - UP - LEFT RIGHT - DOWN - LEFT RIGHT - 1, 2, 3 |

Table 1-1-3 Timings for Foot Drill on the March

| Command | Timings |
|--|--|
| HALT | ONE TWO |
| CHANGE STEP | LEFT RIGHT LEFT |
| MARK TIME FROM MARCH | CHECK |
| HALT FROM MARK TIME | ONE TWO |
| CHANGE STEP WHILST MARKING TIME | LEFT LEFT RIGHT |
| FORWARD FROM MARK TIME | DOWN - LEFT |
| TURNS LEFT/RIGHT | CHECK - BLOCK - LEFT/RIGHT |
| ABOUT TURN | CHECK - LEFT - RIGHT - LEFT - FORWARD |
| EYES LEFT/RIGHT/FRONT | CHECK - ROUND |
| SALUTING ON THE MARCH | CHECK - UP - 2, 3, 4, 5, DOWN - SWING |
| SALUTING, AT THE HALT | ONE - LEFT RIGHT - DOWN |
| DOUBLE MARCH FROM QUICK MARCH | CHECK - LEFT |
| QUICK MARCH FROM DOUBLE MARCH | CHECK - LEFT RIGHT LEFT |
| HALT FROM THE DOUBLE MARCH | ONE TWO - ONE TWO |
| STEP SHORT/OUT | CHECK - LEFT |
| QUICK TO SLOW MARCH | ONE TWO - LEFT RIGHT LEFT |
| SLOW TO QUICK MARCH | ONE TWO - LEFT RIGHT LEFT |

UNCLASSIFIED

NZAP 2.4 Manual of Ceremonial and Drill
 Part 1 – Foot and Weapons Drill
 Chapter 1 – Basic Principles

Version 6.00
 13 June 2023

Table 1-1-4 Timings for Rifle Drill at the Halt

| Command | Timings |
|----------------------------------|--|
| STAND AT EASE | ONE - LEFT RIGHT - TWO - LEFT RIGHT - THREE |
| ATTENTION AND SHOULDER ARMS | ONE - LEFT RIGHT - TWO |
| PRESENT ARMS | ONE - LEFT RIGHT - TWO |
| GROUND/TAKE UP ARMS, ATTENTION | ONE - LEFT RIGHT - TWO - LEFT RIGHT - THREE - LEFT RIGHT - FOUR |
| SALUTING, AT THE HALT | UP - LEFT RIGHT - DOWN |
| MARKERS (WHEN CALLED FOR PARADE) | ONE - LEFT RIGHT - TWO - LEFT RIGHT - THREE - LEFT RIGHT - 1, 2, 3 |
| SHOULDER FROM THE PORT | ONE - LEFT RIGHT - TWO - LEFT RIGHT - THREE - LEFT RIGHT - FOUR - LEFT RIGHT - FIVE - LEFT RIGHT - SIX |

Table 1-1-5 Timings for Sword Drill

| Command | Timings |
|-----------------------------|---|
| ATTENTION AND STAND AT EASE | ONE |
| DRAW SWORDS | ONE - LEFT RIGHT - 1, 2, 3, 4, 5, LEFT RIGHT - ONE |
| SALUTING LEFT/RIGHT/FRONT | UP - LEFT RIGHT - DOWN |
| RETURN SWORDS | ONE - LEFT RIGHT - TWO - 1, 2, 3, 4, 5, LEFT RIGHT - ONE |
| STAND AT EASE (WITH RIFLES) | ONE - LEFT RIGHT - TWO - LEFT RIGHT - THREE (MOVE ON THIRD COUNT) |

- e. **Forming a hollow square.** For instructional purposes, instructors may use the hollow square formation. The square may only be formed from a flight in three ranks. The procedure for forming a hollow square is shown in [Table 1-1-6](#).
- f. **Inspections.** When a unit parading in three ranks is to be inspected, the ranks are to be opened for the inspection and closed on completion of the inspection.
- (1) The inspecting officer or non-commissioned officer (NCO) starts the inspection from the right flank, moving along the front rank to the left flank, after which the rear of the front rank is to be inspected from left to right flank. The inspection of the centre and rear ranks is to be carried out in the same manner. Each individual is to be inspected from head to foot, both front and rear.
 - (2) Each rank is to be inspected in the position of attention. Ranks not being inspected may be stood at ease at the discretion of the inspecting officer.
 - (3) ORs, when ordered to adjust equipment or dress during an inspection, are to bend the right knee and drive the right foot back so that the instep of the right foot is approximately 3 cm to the right rear of the heel of the left foot to a position that maintains the angle of attention with the feet. ORs are to make the necessary adjustment, grounding arms if necessary, after which the position of attention is to be resumed.

Table 1-1-6 Forming a Hollow Square

| Serial | Commander | Command | Action |
|--|---|---|---|
| 1 | Instructor | FORM A HOLLOW SQUARE FRONT RANK STAND FAST CENTRE AND REAR RANKS OUTWARDS – TURN | <ul style="list-style-type: none"> – the centre rank is to turn left; and – the rear rank right. |
| 2 | Instructor | QUICK – MARCH | <ul style="list-style-type: none"> – the centre rank steps off and wheels right; and – the rear rank steps off and wheels left. |
| 3 | As the last person completes the wheel— | | |
| | Instructor | CENTRE AND REAR RANKS HALT INWARDS TURN | |
| The reverse actions are carried out to restore the ORs to a flight in three ranks. | | | |
| 4 | Instructor | FORM THREE RANKS FRONT RANK STAND FAST CENTRE AND REAR RANKS OUTWARDS – TURN QUICK – MARCH | <ul style="list-style-type: none"> – the centre rank steps off and wheels left; and – the rear rank steps off and wheels right. |
| 5 | Instructor | CENTRE AND REAR RANKS HALT INWARDS – TURN | <ul style="list-style-type: none"> – the centre and rear ranks turn forward. |

- g. The major items to be noted when inspecting a parade are as follows—
- (1) Personal grooming and cleanliness of the individuals.
 - (2) Uniform, footwear and other equipment are to be clean, in good repair and worn correctly.
- h. The following details are to be examined during an inspection—
- (1) **Service dress cap.** The Service dress cap is to be clean and is to be worn square on the head. The cap badge is to be fitted in the centre front of the cap in line with the top edge of the black band.
 - (2) **Field Service cap.** The field Service cap is to be clean and is to be worn so that the lower button of the cap is in the centre of the forehead and the cap pulled to the right, until the edge is 25 mm above the centre of the right eyebrow.
 - (3) Cleanliness. The hands, face, ears and neck are to be clean.
 - (4) **Grooming.** Personnel are to be groomed in accordance with [NZAP 207](#) *Royal New Zealand Air Force Dress Instructions*.
 - (5) **Neckwear.** The collar is to be clean and the tie, if worn, is to be neatly tied with a double Windsor knot.

- (6) **Buttons.** All buttons are to be sewn on securely so that the crown is uppermost and the eagle horizontal.
- (7) **Rank and arm badges.** Are to be sewn/worn in accordance with [NZAP 207](#).
- (8) **Uniform.** Uniform is to be neatly pressed, in good repair and correctly worn in accordance with [NZAP 207](#).
- (9) **Pockets.** All pockets are to be worn flat and buttoned where buttons are provided.
- (10) **Jewellery.** Jewellery is only be worn as prescribed in accordance with [NZAP 207](#).
- (11) **Medal ribbons.** Medal ribbons may be worn on No.1 Service Dress (SD) jackets and working dress shirts in accordance with [NZAP 207](#).
- (12) **Aircrew brevets.** When an aircrew brevet is worn with medal ribbons, it is to be placed centrally above the top row. When this results in the brevet being partly obscured by the lapel or collar, the badge is to be moved towards the sleeve shoulder seam so as to display as much of the brevet as the available space permits.
- (13) **Mourning bands.** Mourning bands, when worn, are to be of black crepe, 8 cm wide, and are to be secured midway between the point of the elbow of the left arm and shoulder.
- (14) **Footwear.** Boots and shoes are to be clean and in good repair, laced straight across and fastened by a knot. Loose ends of laces are not to show when wearing boots.
- (15) **Other Service-issue head dress.** These may be worn for parade rehearsals as defined by the parade instruction or at the discretion of the PCDR.

1.1.7 Numbering

- a. On the command—

FRONT RANK – NUMBER

- ORs of the front rank are to number smartly from the right.
- The right hand person is to call out 'one', the next person on the left is 'two', and so on.
- Each person in the centre and rear ranks is to listen for the number given by the corresponding person of the front rank, and retain that number.
- Each person is to look straight to the front and keep their head steady when calling out their number.

UNCLASSIFIED

NZAP 2.4 Manual of Ceremonial and Drill
 Part 1 – Foot and Weapons Drill
 Chapter 1 – Basic Principles

Version 6.00
 13 June 2023

1.1.8 Intervals

- a. Each individual is to occupy a lateral space of 1 m in the ranks.
- b. The lateral space between units is to be measured in paces of 75 cm.

1.1.9 Distance

- a. The distance between ranks is to be 75 cm measured from heel to heel when in close order.
- b. The distance between units in formation is to be measured in paces of 75 cm from the heels of the front rank of one unit to the heels of the front rank of the unit next in succession.

1.1.10 Length of pace in marching

The length of pace in marching is listed in Table [1-1-7](#).

1.1.11 Time in marching

- a. The number of paces to the minute for marching is listed in Table [1-1-8](#).
- b. A drummer using a metronome may be used to beat the correct time when drill instruction is being carried out. ORs are to note the time carefully, after which they are to be marched to the time indicated; the drummer is to tap out the right timing at intervals as a check.

Table 1-1-7 The Length of Pace in Marching

| Movement | Length of Pace |
|-------------------------------|----------------|
| Slow March | 75 cm |
| Quick March | 75 cm |
| Sideways March | 30 cm |
| Double March | 1 m |
| Stepping Short | 50 cm |
| Stepping Out | 80 cm |
| Stepping Forward and Backward | 75 cm |
| Stepping Off | 60 cm |
| Open/Close Order | 40 cm |

Table 1-1-8 Marching Rates

| Marching | Paces per minute |
|-------------------------------|-----------------------------|
| Slow Time | 60 paces per minute |
| Quick Time | 120 paces per minute |
| Double Time | 180 paces per minute |
| Sideways Marching | To the cadence of ONE - TWO |
| Stepping Forward and Backward | 120 paces per minute |

Chapter 2 – Saluting

1.2.1 Reason for saluting

- a. Saluting by non-commissioned ranks (NCRs) is a recognition of the Sovereign's Commission, being indirectly a salute to the Sovereign through the individual holding the Sovereign's authority. Returning a salute from an NCR is not an acknowledgment of their salute to the officer personally, but a recognition of the fact that, through an officer, they have given an outward sign of their loyalty to the Sovereign and to their Service.
- b. It is important that NCRs salute, and it is the responsibility of all officers to see that saluting is carried out.

1.2.2 Instructions for saluting

The instructions given in this chapter apply to general principles of saluting. The instruction and details of the method of saluting are laid down in—

- (1) Part 1, [Chapter 3](#) *Foot Drill*;
- (2) Part 1, [Chapter 5](#) *Weapons Drill*;
- (3) [Part 2](#) *Formation Drill*;
- (4) [Part 3](#) *Ceremonial Drill*; and
- (5) [Part 4](#) *Queen's Colour and Squadron Standard Ceremonial Drill*.

1.2.3 Officers saluting without weapons

- a. Officers are to salute with the right hand unless physically unable to do so, in which case they are to salute with the left hand. When officers are using the salute to pay a compliment, they are to salute in the same way as other ranks (ORs).
- b. Officers are to return salutes made to them. In returning salutes, officers are to look in the direction of persons saluting them.
- c. When several officers are together the following apply—
 - (1) It is the responsibility of the senior officer present to return a salute.
 - (2) If the senior officer fails to see the salute, it is the duty of the next senior officer in the party to acknowledge it.
 - (3) When several officers are grouped together and salutes are likely to pass unnoticed by the senior officer, another officer is to be detailed to acknowledge salutes.
- d. Officers are to salute their senior before addressing them on duty. Officers below the rank of Squadron Leader (SQNLDR) are to salute officers of and above that rank. Officers of the rank of SQNLDR and above are to salute their superiors in rank.

UNCLASSIFIED

NZAP 2.4 Manual of Ceremonial and Drill
Part 1 – Foot and Weapons Drill
Chapter 2 – Saluting

Version 6.00
13 June 2023

- e. Officers are to salute those officers of the Royal New Zealand Navy (RNZN), the New Zealand Army (NZA), Commonwealth forces and foreign Services in uniform, who would be saluted by officers of corresponding rank in those Services.
- f. Officers in uniform who are recognised and acknowledged in greeting by personnel in civilian clothes, are to return the acknowledgment with a verbal response of 'Thank you'.

1.2.4 Officers saluting when on an armed parade

Officers, when on parade with armed personnel, are to salute with the right hand. The right hand is brought to the salute on the second movement of the 'PRESENT – ARMS' and the hand is brought down on the final movement of the 'SHOULDER – ARMS'.

1.2.5 ORs saluting with and without weapons

- a. ORs are to salute with the right hand except when physically unable to do so, in which case they are to salute with the left hand.
- b. ORs, when addressing an officer, are to halt two paces from the officer. They are then to salute, address the officer and salute again before withdrawing.
- c. When an OR sees an officer approaching, they are to stand at attention, face the officer and salute when the officer is three paces from them. The hand is brought down to the side after a pause equal to five paces. When two or more ORs are standing together, the senior OR present is to face the officer and call the whole party to attention before saluting.
- d. When several ORs are walking together, they are all to salute when passing or overtaking an officer, except when they are being marched in a party. If an OR can clearly identify an officer from a distance across a road, or if they are passing an officer directly, they are to salute by bringing the right hand to the salute on the third pace before reaching the officer; at the same time the OR is to turn their head smartly in the direction of the officer. The OR lowers their hand on the third pace after passing the officer and turns their head to the front.
- e. When an OR is in uniform and recognises officers who are dressed in civilian clothes, they are to salute where appropriate.
- f. NCOs and ORs, when addressing a Warrant Officer (W/O), are to halt two paces from the W/O and are to address males as 'Sir' and females as 'Ma'am', or 'Warrant Officer' followed by their surname. ORs, when addressing an NCO, are to halt two paces from the NCO and are to address the NCO by the full title of their rank. ORs when reporting to, or being addressed by, their seniors in rank are to stand at attention.
- g. When headdress is not worn, or when an OR is carrying anything other than a weapon that prevents them from saluting, they are to stand at attention when an officer passes. If an OR is walking, they are to turn their head smartly towards the officer when passing and give a verbal greeting.

UNCLASSIFIED

NZAP 2.4 Manual of Ceremonial and Drill
Part 1 – Foot and Weapons Drill
Chapter 2 – Saluting

Version 6.00
13 June 2023

- h. ORs are to salute commissioned officers of the Royal New Zealand Air Force (RNZAF), the RNZN, the NZA, Commonwealth forces and foreign Services at all times.
- i. An OR, when standing still with a rifle, is to turn towards the officer and rifle salute as the officer is passing.
- j. When passing an officer, an OR carrying a rifle is to salute as directed in Part 1, [Chapter 5](#).
- k. When an OR carrying a rifle approaches to address an officer, they are to halt two paces from the officer before saluting. Before withdrawing they are to salute for the second time, after which they are to turn about and march off in quick time, observing the same pauses between movements as when approaching an officer while not carrying arms.

1.2.6 Officer cadets and Air Force cadets

Officer Cadets and Air Force Cadets are subject to the same regulations for saluting as ORs.

1.2.7 Trumpeters and buglers

A trumpeter/bugler carrying an instrument is to salute by placing the bell of the instrument on the right hip. The instrument is to be held in the right hand with the mouthpiece pointing upwards to the right front at an angle of 45 degrees. The musician is to turn their head towards the officer.

1.2.8 Compliments paid when in civilian attire

Officers and ORs are to pay and return compliments verbally when wearing civilian clothes.

1.2.9 Compliments paid during a national anthem

- a. When the New Zealand National Anthem or a foreign national anthem is played, on any occasion other than as given in paragraph [1.2.9f](#), all personnel not under the orders of an officer commanding a parade are to face the required direction, stand at attention and, if wearing uniform headdress, salute. When wearing civilian clothes headdress is to be removed.
- b. Individual officers and ORs are to stand at attention, headdress removed, whenever the New Zealand National Anthem or any foreign national anthem is played within a building, unless otherwise ordered.
- c. All Service members, when in uniform, are to remove their headdress in church.
- d. When a party of ORs are on the march, the commander of the party is to halt them and is to salute during the playing of the New Zealand National Anthem.

- e. When a party of ORs are halted, the commander of the party is to call them to attention and is to salute during the playing of the New Zealand National Anthem.
- f. Sentries are to stand to attention during the playing of the New Zealand National Anthem.

1.2.10 Raising/lowering of the RNZAF Ensign

On occasions when the RNZAF Ensign is being raised/lowered at RNZAF Bases, all ranks within view of the ensign or within hearing of the trumpet calls or on the command 'STAND FAST' are to stand at attention and are to face the flagpole during the period when the ensign is being raised/lowered. Officers are to salute. All personnel react to the command 'CARRY ON' by returning to their duties.

1.2.11 Guard salutes

Officers and ORs are to stand at attention when the guard salute is being played.

1.2.12 Funerals

Officers and ORs in uniform, when passing a civilian or Service funeral cortege, are to salute the casket as it passes.

1.2.13 Passing troops or naval landing parties with uncased Sovereigns Colours or Squadron Standards

Officers and ORs, when passing troops or naval landing parties with uncased Squadron Standards (Sqns), flags or Sovereign's Colours, are to salute the Sqns, flags or Sovereign's Colours, except when carried by units forming part of an escort at a Service funeral. Officers and ORs are to halt, face the Sqns, flag or Sovereign's Colour and salute. Cased Sovereign's Colours are not to be saluted.

Note: The details for paying compliments to the Sovereign's Colours etc are laid down in Part 1, [Chapter 4 Marching](#).

1.2.14 Boarding or leaving Their Majesty's ships

When boarding or leaving any of their Majesty's ships all ranks are to salute the quarter deck.

1.2.15 Mechanical or electrical vehicles

Officers and ORs are to salute the occupant/s of a vehicle displaying either a distinguishing flag or, where no flag is flown, exposed star plates. Where no distinguishing emblem is visible and it is apparent that the occupant/s are entitled to a salute, then compliments must be paid.

UNCLASSIFIED

NZAP 2.4 Manual of Ceremonial and Drill
Part 1 – Foot and Weapons Drill
Chapter 2 – Saluting

Version 6.00
13 June 2023

1.2.16 Parties on the march

When an armed or unarmed party is passing an officer entitled to a salute, the officer or OR in charge is to give the command 'EYES – RIGHT/LEFT', and salute. An armed individual is to rifle salute.

1.2.17 Compliments with the sword

The instructions for paying compliments with the sword are given in Part 1 [Chapter 6 Sword Drill](#).

1.2.18 Bicycles

- a. An officer and OR passing each other on bicycles are to pay and return compliments verbally when passing.
- b. A person astride or holding a stationary bicycle is to salute if such action can be done safely. The same applies to a person wheeling a bicycle. If a salute cannot be safely given, a verbal greeting/acknowledgment is to be made.

1.2.19 Within buildings and offices

- a. On entering and within the confines of buildings other than those that are their normal place of duty, all personnel are to wear service headdress. If a salute cannot be given to an officer, because of the confines of the area, a verbal greeting is to be made.
- b. ORs are to salute when entering and leaving the office of an officer.
- c. Officers are to salute when entering and leaving the office of another officer senior to themselves or as a mark of respect to peers.

1.2.20 Warrant officers

When W/Os are carrying out the duties of an officer, eg when acting as orderly officer during RNZAF Ensign raising, they are to pay compliments as would a commissioned officer.

1.2.21 Saluting on ceremonial parades

- a. When the reviewing officer is being received, and for the salute following the 'advance in review order', all officers are to salute.
- b. When a wing marches past by squadrons in close column of flights, the wing commander and squadron commanders (PCDRs) only, are to salute.
- c. In column of route, compliments are to be paid by flights; the wing commander, PCDRs, flight commanders (FLTCDRs), wing adjutant (WADJ) and squadron adjutants (SADJs) and W/Os are to salute.
- d. When a squadron marches past by flights, in column, compliments are to be paid by flights; the PCDR, FLTCDRs and SADJ are to salute.

- e. When a squadron marches past in close column of flights, the PCDR only is to salute while the remainder are to turn their head and eyes in the direction ordered.
- f. W/Os and NCOs in command of flights are to salute when marching past, if appropriate.

Note: For paragraphs [1.2.21c.](#) and [1.2.21d.](#), wing and squadron command personnel should salute on the command of the respective No. 1 FLTCDR. However, local conditions eg parade ground restrictions or placement of marker posts, may dictate other arrangements be agreed upon in rehearsals. It is often the case that the wing/parade commander has gone past the dignitary before the command is given.

1.2.22 Further information on compliments

The honours and salutes to be given on ceremonial occasions are detailed in—

- (1) DFI 113 *Defence Force Instruction for Visits, Ceremonial and Protocol* (TBI).
- (2) AFGO *Air Force General Orders*.

1.2.23 Saluting at the halt and on the march

Saluting to the front at the halt is carried out in two movements.

- (1) On the command—

TO THE FRONT – SALUTE

BY NUMBERS ONE

- The right hand is brought up smartly with a sideways circular motion to the side of the head.
- The palm of the hand is to the front and the fingers and thumb fully extended and pressed together.
- The forefinger is 25 mm behind and to the right of the right eye.
- The wrist is straight.
- The elbow is in line and square with the right shoulder.

- (2) On the command—

BY NUMBERS TWO

- The right hand is returned smartly to the side by the shortest way, without striking the thigh.
- When judging the time, a pause, equal to one pace in quick time, is observed between the two movements.

1.2.24 Saluting to the right/left at the halt

Saluting to the right/left at the halt is carried out in two movements.

(1) On the command—

TO THE RIGHT/LEFT – SALUTE

BY NUMBERS ONE

- The head is turned sharply in the direction ordered.
- At the same time, the movements detailed in paragraph [1.2.23\(1\)](#) for saluting at the halt are carried out.

(2) On the command—

BY NUMBERS TWO

- The right hand is returned smartly returned to the side by the shortest way, without striking the thigh.
- At the same time, the head is turned smartly to the front.
- When judging the time, a pause, equal to one pace in quick time, is observed between the two movements.

1.2.25 Saluting on the march in quick time

- a. ORs are taught to salute to the front to accustom them to approach officers correctly. The pause between the two stages of the salute represents the delivery/receipt of a message.
- b. ORs are taught to salute to the right/left to accustom them to salute officers correctly when passing them.
- c. ORs are to be practiced in saluting to the right/left when marching two or three abreast, and saluting points are to be placed at intervals for this purpose. The OR nearest the saluting point is to indicate the time. The ORs are to act together and are to start the salute three paces before reaching the saluting point.
- d. The reason for teaching ORs the movement of saluting to the front on the march is to accustom them to salute correctly when officers are crossing their line of approach.

(1) On the command (given on the right foot)—

AT THE HALT – SALUTE

- ORs halt, observe a pause equal to one pace in quick time and then salute to the front.
- After completing the salute, ORs observe a pause equal to four paces in quick time and then salute for the second time.
- After the second salute ORs observe a pause equal to one pace in quick time, turn about, observe another pause equal to one pace in quick time and then start marching (starting with the left foot).

- (2) On the command (given on the left foot)—

TO THE RIGHT/LEFT/FRONT – SALUTE

- A full pace forward with the right foot is completed and arms checked to the side.
- When the left foot again touches the ground, the head is turned smartly in the direction ordered and the salute is given.
- After marching four paces at the salute, the right arm is brought to the side and the head turned to the front as the right foot comes to the ground.
- The normal arm swing is resumed as the next forward pace is taken with the left foot.

Note: During the salute the left arm is kept steady at the side.

1.2.26 Eyes right/left/front

- (1) On the command (which is given on the left foot)—

EYES – RIGHT/LEFT

- A full forward pace is completed with the right foot.
- When the left foot again comes to the ground, the head is turned smartly in the direction ordered.

- (2) On the command (which is given on the left foot)—

EYES – FRONT

- A full forward pace is completed with the right foot.
- When the left foot again comes to the ground the head is turned smartly to the front.

Note: During these movements the arms are swung in the normal manner.

1.2.27 Officers

Officers, when in charge of units on the march that are required to salute as a unit, are to give their orders on the successive left feet so that a smooth order/action results. Officers saluting actions are to be carried out on successive left feet.

Chapter 3 – Foot Drill

1.3.1 General

- a. During the initial stages of training in foot drill, instruction is to be given in open order.
- b. Exercises are to be taught first by numbers and when proficiency has been obtained by judging the time a pause equal to one pace in quick time is to be observed between successive movements except where otherwise stated.

1.3.2 Timing

Timings for foot drill are contained in Table [1-3-1](#).

1.3.3 Formation of a flight

A marker is to be detailed.

- (1) On the command—

FLIGHT – MARKER

- the marker—
 - comes to attention;
 - marches out in quick time;
 - halts facing the instructor at a distance of three paces; and
 - stands at ease.

- (2) On the command—

ON – PARADE

- The marker and flight come to attention.
- The flight observes a pause of one pace in quick time, then marches forward and forms up in three ranks on the marker.
- After observing a pause equal to one pace in quick time, all other ranks (ORs), with the exception of the right file, turn their heads and eyes to the right.
- At the same time ORs in the front rank raise their left arms fully extended with hands clenched and the back of the hand upward, knuckles touching the right shoulder of the OR immediately to their left.
- The right-hand guide of the front rank turns their head and eyes to the left.
- After observing a pause of one pace in quick time, each OR takes up their dressing in line by moving with short sharp paces until they are just able to see the lower part of the face of the second person beyond them.

Note: The arm up is only a training aid. It can be dropped and re-introduced when necessary. When trainees have reached a satisfactory skill level judging the distance, the arm up is dropped from all parades. The shoulders are kept square to the front, without bending the body or the head backward or forward. ORs in the centre and rear ranks are to cover ORs in the front rank at one pace distance.

| Table 1-3-1 Foot Drill Timings | |
|--|---|
| Command | Calling |
| ATTENTION AND STAND AT EASE | ONE |
| FLIGHT (brace up) | ONE |
| IN OPEN/CLOSE ORDER, RIGHT - DRESS | ONE TWO - ONE TWO |
| # PACES FORWARD AND REAR | ONE TWO - ONE TWO |
| RIGHT DRESS (including without intervals) | UP - LEFT RIGHT - MOVE |
| SIDEWAYS MARCH | ONE TWO ETC |
| TURN/INCLINE AT THE HALT | ONE - LEFT RIGHT - TWO |
| SALUTE AT THE HALT | UP - LEFT RIGHT - DOWN |
| DISMISS | ONE - LEFT RIGHT - TWO - LEFT RIGHT - 1, 2, 3 |
| OFFICER ON PARADE DISMISS | ONE - LEFT RIGHT - TWO - LEFT RIGHT - UP - LEFT RIGHT - DOWN - LEFT RIGHT, 1, 2, 3 |

1.3.4 Blank files

- a. If there are only two ORs in any file, the centre rank is to be left blank; and if there is only one person, the centre and rear ranks are to be left blank. Incomplete files are to be positioned as the second file from the left flank. These are to be known as blank files.
- b. A blank file of one person in a flight, which when halted has been turned about, is to take two paces forward.
- c. If fewer than nine ORs are to be formed up as a squad in two ranks with the same interval between people.

1.3.5 Open and close order

- a. Open Order Right Dress

- (1) On the command—

IN OPEN ORDER

RIGHT – DRESS

- The front rank takes three 40 cm paces forward and halts.
- The rear rank takes three 40 cm paces back and halts.
- The centre rank stands fast.
- After a pause equal to two paces in quick time, each OR, except the right hand guide of each rank, turns their head to the right.
- After this movement, there is a pause equal to two paces in quick time and then each OR takes up dressing in line by moving with short, sharp paces until they are able to see the lower part of the face of the second person beyond them.

Note: For training purposes, personnel are to raise their left arms, hands clenched and the backs of the hands upwards with the knuckles touching the shoulder of the person immediately on their left. The raising of the arm is dropped when lateral distance can be judged effectively.

Note: The shoulders are kept square to the front without bending the body or head forward or backward. ORs in the centre and rear ranks are to cover ORs in the front rank at one pace distance.

(2) On the command—

EYES – FRONT

- Each OR except the right/left person of each rank, turns their head smartly to the front.

Note: When the arm up is used in training, the front rank are to bring their arms smartly to their sides.

b. Close Order Right Dress

(1) The instructor explains that the reverse process takes place.

(2) On the command—

IN CLOSE ORDER

RIGHT – DRESS

- The front rank takes three 40 cm paces to the rear.
 - The rear rank takes three 40 cm paces forward.
 - After a pause equal to two paces in quick time each OR, except the right hand guide of each rank, turns their head to the right.
 - After this movement, there is a pause equal to two paces in quick time and then each OR takes up dressing in line by moving with short, sharp paces until they are able to see the lower part of the face of the second person beyond them.
- (3) The instructor is to swap ranks around during practices to give each of the ORs exposure to all movements.

1.3.6 Open and close order march

For the purposes of speed, the instructor can give an open/close order without the dressing taking place. It is the same drill without the head movement.

1.3.7 Dressing

- a. Each individual is responsible for their correct dressing on parade. This principle applies during all parade movements.
- b. To correct the dressing of a flight/squadron/wing, the flight/squadron/wing commander gives the command 'RIGHT/LEFT DRESS'.
- c. When the dressing has been corrected, the command 'EYES FRONT' is given.
- d. Dressing is carried out as expeditiously as possible.
- e. The drill for the dressing is same with and without weapons.

1.3.8 Dressing without intervals

- a. Dressing without intervals is carried out—
- (1) when space is very limited;
 - (2) when an address is being given; or
 - (3) when forming a guard of honour in two ranks.
- b. The general principles for dressing without intervals are the same as those given in paragraph [1.3.7b.–d.](#), except that the arm is not raised and the distance between personnel is about 25 cm from shoulder to shoulder.
- c. When it is necessary to dress without intervals the command given is—

WITHOUT INTERVALS
RIGHT/LEFT – DRESS

1.3.9 Attention, stand at ease, stand easy

- a. The position of attention

The position of attention is one of alertness in readiness for a word of command and the muscles of the body are therefore to be controlled to await any order that may be given.

- (1) The instructor is to—
 - demonstrate and explain the movement;
 - break the movement into parts if necessary and explain each part; and
 - supervise individual imitation then conduct repetition on command.
- (2) On the executive part of the word of command—

PARADE/FLIGHT/SQUADRON
PARADE, FLIGHT, SQUADRON
SHUN

 - The left foot is brought smartly into the right, without stamping.
 - The arms are brought to the sides.
 - The knee is slightly bent during this movement to allow the foot to be raised no more than 20 cm.
 - The heels are brought together and in line.
 - The toes of the feet are turned outwards at an angle of approximately 45 degrees.
 - The knees are straight.
 - The weight of the body is balanced on both feet and is evenly distributed between the fore-part of the feet and the heels.
 - The body is erect and is carried evenly over the thighs.



Figure 1-3-1 Position of Attention

- The shoulders (which are level and square to the front) are drawn downwards and backwards without strain or stiffness so as to bring the chest to its natural position.
- The arms hang easily from the shoulders and are as straight as the natural bend of the arm (when the muscles are relaxed) will allow.
- The wrists are straight.
- The palms of the hands are turned towards the thighs.
- The fingers are lightly clenched.
- Thumbs are to the front, touching the forefingers.
- The thumbs and tips of the fingers rest lightly on the thighs with the thumb on the side seam of the trousers.
- The neck is straight.
- The head is erect.
- The chin is drawn in.
- The eyes are to look straight to the front.
- Breathing is not restrained.
- No part of the body is stiff or strained.
- Personnel are to move their toes and clench the major muscles in their thighs and buttocks to ensure blood pressure is maintained as a measure against fainting. These actions are to be conducted without being visible to onlookers.

- See Figure [1-3-1](#).
- (3) Common faults—
- (a) Positioning of feet and gaps between heels.
 - (b) Posture.
 - (c) Positioning of hands relative to seam of trousers (where appropriate).
 - (d) Positioning of hand – back of hand outwards.
 - (e) Looking down.
 - (f) Eye movement.
- b. Stand at ease
- (1) The instructor is to—
- demonstrate and explain the movement;
 - break the movement into parts, if necessary, and explain each part; and
 - supervise individual imitation then conduct repetition on command.
- (2) On the command—
- STAND AT – EASE**
- The left foot is punched crisply 30 cm to the left (the knee is bent slightly during this movement to allow the foot to be raised 20 cm).
 - The weight of the body rests evenly on both feet.
 - At the same time the hands are placed smartly behind the back.
 - The back of the right hand is placed in the palm of the left hand, thumbs are crossed right over left.
 - The arms are to hang easily to their full extent.
 - See Figure [1-3-2](#).
- Note:** Although this position is more relaxed than the position of attention, no movement is to be made.
- (3) Common faults—
- Lack of crispness.
 - Distance between the heels.
 - Hand placement/positioning.



Figure 1-3-2 The Position of Stand at Ease

c. Standing easy

- (1) The instructor is to—
 - demonstrate and explain the movement;
 - break the movement into parts if necessary and explain each part; and
 - supervise individual imitation then conduct repetition on command.
- (2) On the command—

STAND – EASY

 - The limbs, head and body may be moved, but not the feet. (If the feet are moved the dressing may be lost.)
 - Slouching, talking and unnecessary movement is not to be allowed.
 - ORs standing easy are to assume the position of stand at ease as soon as a cautionary word of command is given, so as to be ready to carry out the next command.

1.3.10 Turns at the halt

a. Turns at the halt are divided into two movements.

(1) The instructor is to—

- (a) demonstrate and explain the movement;
- (b) break the movement into parts if necessary and explain each part; and
- (c) supervise individual imitation then conduct repetition on command.

b. Left turn at the halt

On the command—

LEFT – TURN

(a) First movement—

- A turn is made to the left through 90 degrees, on the left heel and the right toe, by raising the right heel and the left toe.
- Both knees are kept straight.
- The body is kept erect.
- On completion of this preliminary movement the left foot is flat on the ground.
- The right heel is raised, toes and ball of the foot contacting the ground.
- Knees are straight and the weight of the body is on the left foot.
- See Figure [1-3-3](#).



Figure 1-3-3 1st Position for Left Turn at the Halt

(b) Second movement—

- The right foot is punched in beside the left.
- At the same time the knee is bent sufficiently for the foot to clear the ground by 20 cm.

Note: During all turning movements the arms are kept close to the sides as for the position of attention.

c. Right turn at the halt

On the command

RIGHT – TURN

- The details for turning to the right and inclining to the right are the same as for movements to the left, except that the word 'RIGHT' is substituted for the word 'LEFT'.

1.3.11 Inclining to the right/left

Inclining is carried out as for turns at the halt except that the body is turned through no more than 45 degrees.

1.3.12 Turning about

a. The about turn is carried out in two movements.

(1) On the command—

ABOUT – TURN

b. First movement—

- An about turn is to the right made by pivoting on the right heel and the left toe.
- Both knees are kept straight.
- The body is erect.
- When this preliminary movement is completed—
 - the right foot is flat on the ground;
 - the left heel is raised;
 - both knees are straight; and
 - the weight of the body is on the right foot.
- See Figure [1-3-4](#).



Figure 1-3-4 1st Position for About Turn

- c. Second Movement—
- The left heel is brought smartly up to the right without stamping.
 - The knee is bent sufficiently for the foot to clear the ground by 20 cm.
- (1) Common faults—
- (a) Not pivoting through full turn of 90 degrees.
 - (b) Bent knees (the leg taking the weight).
 - (c) Weight distribution wrong (leaning back on heels).
 - (d) Lack of crispness on last movement.
 - (e) Looking down.
 - (f) Arm movement.

1.3.13 Saluting to the front when halted

- a. The instructor—
- Demonstrates and explains the movement.
- b. Saluting to the front when halted is carried out in two movements.
- (1) On the command—
- TO THE FRONT – SALUTE
BY NUMBERS ONE**
- The right hand is brought up smartly with a sideways circular motion to the side of the head.
 - The palm of the hand is to the front and the fingers and thumb fully extended and pressed together.
 - The forefinger is 25 mm behind and to the right of the right eye.
 - The wrist is straight.
 - The elbow in line and square with the right shoulder.
 - See Figure [1-3-5](#).



Figure 1-3-5 Position for Saluting to the Front when Halted

- (2) On the command—
BY NUMBERS TWO
- the right hand is cut smartly to the side by the shortest way, without striking the thigh.
- c. When judging the time, a pause equal to one pace in quick time, is observed between the two movements.

1.3.14 Saluting to the right/left at the halt

- a. Saluting to the right/left at the halt is carried out in two movements.
- (1) On the command—
TO THE RIGHT/LEFT – SALUTE
BY NUMBERS ONE
- The head is turned sharply in the direction ordered.
 - At the same time the movements detailed for saluting are carried out.
 - See Figure [1-3-6](#).



Figure 1-3-6 Saluting to the Right and to the Left at the Halt

(2) On the command—

BY NUMBERS TWO

- The right hand is smartly returned to the side by the shortest way, without striking the thigh.
 - At the same time the head is turned smartly to the front.
- b. When judging the time, a pause, equal to one pace in quick time, is observed between the two movements.

1.3.15 Saluting on the march in quick time

- a. ORs are taught to salute to the front to accustom them to approach officers correctly (the pause between the two movements of the salute represents the delivery or receipt of a message).
- b. ORs are taught to salute to the right/left to accustom them to salute officers correctly when passing them.
- c. ORs are to be practiced in saluting to the right/left when marching two or three abreast. Saluting points are to be placed at intervals for this purpose. The OR nearest the saluting point indicates the time. ORs act together and start the salute 3 paces before reaching the saluting point.

d. The reason for teaching ORs the movement saluting to the front on the march is to accustom them to salute correctly when officers are crossing their line of approach.

(1) On the command (which is given on the right foot)—

AT THE HALT – SALUTE

- ORs—
 - halt
 - observe a pause equal to one pace in quick time; and
 - salute to the front.
- After completing the salute, ORs—
 - observe a pause equal to 4 paces in quick time; and
 - salute for the second time.
- After the second salute, ORs—
 - observe a pause equal to one pace in quick time;
 - turn about;
 - observe another pause equal to one pace in quick time; and
 - start marching (starting with the left foot).

(2) On the command (which is given on the left foot)—

TO THE RIGHT/LEFT/FRONT – SALUTE

- ORs complete a full pace forward with the right foot, arms checked to the side.
- When the left foot again touches the ground, the head is turned smartly in the direction ordered and the salute is given.
- After marching four paces at the salute, the right arm is brought to the side and the head is turned to the front as the right foot comes to the ground.
- The normal arm swing is resumed as the next forward pace is taken with the left foot.

Note: During the salute the left arm is kept steady at the side.

1.3.16 Eyes right/left and eyes front

a. On the command (which is given on the left foot)—

EYES – RIGHT/LEFT

- A full forward pace is completed with the right foot.
- When the left foot again comes to the ground the head is turned smartly in the direction ordered.

UNCLASSIFIED

NZAP 2.4 Manual of Ceremonial and Drill
Part 1 – Foot and Weapons Drill
Chapter 3 – Foot Drill

Version 6.00
13 June 2023

b. On the command (which is given on the left foot)—

EYES – FRONT

- A full forward pace is completed with the right foot.
- When the left foot again comes to the ground the head is turned smartly to the front.

c. During these movements the arms are to swing in the normal manner.

1.3.17 Officers

- a. Officers, when in charge of units on the march that are required to salute as a unit, are to give their orders on the successive left feet so that a smooth order/action results.
- b. Officers saluting actions are carried out on successive left feet.

Chapter 4 – Marching

1.4.1 Quick march

On the command—

QUICK – MARCH

- The left foot is advanced evenly to complete a pace of 60 cm.
- The foot meets the ground with the heel.
- During this movement—
 - the rear knee is braced;
 - the arms are as straight as their natural bend will allow;
 - the wrists are straight;
 - the fingers are lightly clenched; and
 - the thumb on top and touching the forefinger.
- After the initial step of 60 cm, marching is to continue with 75 cm steps.
- The right arm is to swing forward to waist height and the left arm is to swing similarly to the rear.
- This forward movement is continued in quick time.
- The legs swing forward freely and naturally from the hip.
- Each leg as it swings forward is bent sufficiently at the knee to enable the foot to clear the ground.

1.4.2 Mark time

a. The instructor is to explain and demonstrate marking time.

(1) On the command (given when the left foot is forward and on the ground)—

MARK – TIME

- A full forward pace is completed with the right foot.
- Marking time will then start on the next beat of the left foot.
- Each foot is raised alternately 20 cm from the ground without moving forward or backward.
- The foot, as it is raised, is pointed downwards and the leg (below the knee) is perpendicular to the ground.

- (2) Common faults—
- Looking down.
 - Rotating forward or in other directions.
 - Arm swing.
 - Toe/foot angle incorrect.
 - Increasing cadence caused by lack of knee lift.
- (3) On the command (given when the right foot is on the ground)—
- HALT**
- One further movement is completed with the left foot.
 - The right foot is brought smartly in line with the left.
- (4) On the command (given when the left foot is on the ground and the right knee raised)—
- FOR – WARD**
- A further movement is completed with the right foot.
 - The quick march is resumed, starting with the left foot.

On the command (given when the right foot is on the ground)—

CHANGE – STEP—

- Two successive movements are completed with the left foot.
- Marking time is restarted with the right foot.

Note: The arms are brought to the sides and kept steady during the execution of the change.

1.4.3 Variation in pace

The detail of variation in pace is the same as that for slow time but carried out in quick time.

1.4.4 Turnings on the march

- a. The detail for turning and inclining is the same as that for slow time but carried out in quick time.
- b. When turning in quick time, the arms are kept steady at the sides.

1.4.5 Moving forward or backward a given number of paces

A formation may be moved forward or backward a maximum of four paces. This movement is used only when it is necessary for other ranks (ORs) to move forward or backward a short distance onto a marker or alignment.

- (1) On the command—

XXX PACES FORWARD/BACKWARD – MARCH

- The formation is to move forward/backward the specified number of paces ordered, starting with the left foot.
- Arms are kept steady at the sides.

1.4.6 Moving sideways a given number of paces

- a. A formation may be moved sideways a maximum of 10 paces. This movement is used only when it is necessary for ORs to move to the left/right over a short distance to a given point or marker.

- (1) On the command—

XXX PACES RIGHT/LEFT SIDEWAYS – MARCH

- The right/left foot is placed 30 cm to the right/left.
- The left/right foot is brought up to the right/left foot (in quick time).
- The necessary number of paces is completed in this manner without a pause.
- Shoulders are kept square to the front.
- Each knee is bent sufficiently to enable the foot to clear the ground by 5 cm during the movement.
- The whole movement should be carried out in strict cadence, ie 120 paces per minute.

- b. When the number of paces for moving sideways are specified, they are not to exceed four in number. If it is required to move a formation a greater number of paces than four up to the maximum of 10 paces, then the command is—

RIGHT/LEFT SIDEWAYS – MARCH

- The command 'HALT' is given when both heels are together.
- The formation then takes a further pace in the direction ordered before bringing the other foot in to the position of attention.

- c. If a formation is to move a greater distance sideways than 10 paces, it is to be turned in the required direction and marched.

1.4.7 Quick march to slow march

- a. On the command (given when the right foot is forward and on the ground)—

INTO SLOW TIME

SLOW – MARCH

- A full forward pace is completed in quick time with the left foot.
- The right foot is brought in beside the left, as for the halt, and the arms brought smartly to the side.
- The next movement of the left foot is the first pace in slow time.

1.4.8 Slow march to quick march

On the command (given when the right foot is forward and on the ground)—

INTO QUICK TIME

QUICK – MARCH

- A full forward pace in slow time is completed with the left foot
- The right foot is then brought in beside the left as for the halt.
- On the next quick time beat, the first pace in quick time is taken with the left foot.
- The arms are swung at the same time.

1.4.9 Marching in double time

a. On the command—

DOUBLE – MARCH

- Individuals step off with the left foot and double march on their toes with easy swinging strides.
- The body is inclined slightly forward, but correct carriage is maintained.
- The feet are raised a few centimetres from the ground during each pace.
- The thigh, knee and ankle joints work freely without stiffness.
- The whole body is carried forward without unnecessary effort, by a push from the rear foot.
- The rear foot is then brought straight to the front.
- The toes placed lightly on the ground.
- The arms are swung easily from the shoulders.
- Arms are to be sufficiently clear from the body to allow full freedom of the chest.
- The arms are bent at the elbow, the forearm forming an angle of about 135° with the upper arm (midway between the straight arm and the right angle at the elbow).
- The hands are slightly clenched, the backs facing outwards.
- The shoulders are kept steady and square to the front.
- The head is erect.

b. On the command (given when the right foot is forward and on the ground)—

HALT

- The forward movement of the body is checked in three paces.
- The right foot is brought up in line with the left foot (in double time).
- At the same time the arms are brought to the sides in the position of attention.

- c. On the command (given when the right foot is on the ground)—
DOUBLE MARK – TIME (FROM DOUBLE – MARCH)
- Two more paces are completed.
 - Then each OR is to mark time starting with the left foot.
 - When marking time, each foot is raised alternately 225 mm from the ground without moving forward or backward.
 - The foot as it is raised is pointed downwards and the leg (below the knee) is perpendicular to the ground.
 - The arms are held in the same position as when double marching, but kept steady at the sides.
- d. On the command—
DOUBLE MARK – TIME (FROM THE HALT)
- Each OR double marks time starting with the left foot.
- e. On the command (given when the left foot is on the ground and the right knee is raised)—
FOR – WARD
- A further movement is completed with the right foot.
 - The double march is resumed starting with the left foot.

1.4.10 Changing from quick time to double time

On the command (given when the left foot is forward and on the ground)—

INTO DOUBLE TIME
DOUBLE – MARCH

- A full forward pace is completed with the right foot.
- The first pace in double time is taken with the left foot.

1.4.11 Changing from double time to quick time

On the command (given when the left foot is forward and on the ground)—

INTO QUICK TIME
QUICK – MARCH

- The forward movement of the body is checked in three paces (in double time).
- The first pace in quick time is taken with the left foot.

Note: The movements are the same for going from double mark time to marching in quick time.

1.4.12 Marching in slow time

a. The balance step

(1) The balance step is an effective method of teaching ORs to control the muscles and limbs, and to acquire correct balance and carriage. It is also a useful preliminary in training ORs to march in slow time. When the ORs have made enough progress to carry out each separate movement of the balance step correctly, the interval between the successive words of command is reduced until they are moving forward with only a short pause between the movements.

(2) On the command—

BALANCE STEP

LEFT FOOT – FRONT

- The head and body are in the position of attention.
- The arms are held steady at the sides.
- The left foot is advanced smartly to the front (about 30 cm) and turned outward at the same angle as when halted.
- Toes point towards, and 5 cm from, the ground.
- The left leg is kept straight.
- The left foot is stretched as it comes forward.
- The right leg is kept straight.
- The body is balanced on the right foot.
- See Figure [1-4-1](#).



Figure 1-4-1 Position for the Balance Step

- (3) On the command—

FOR – WARD

- The left foot is advanced forward in an even movement to complete a pace of 75 cm.
- The left leg is straight with the toes pointing downwards.
- The foot is placed firmly on the ground.
- At the same time the weight of the body is transferred to the left foot.
- The right foot is raised off the ground, with the leg straight and the foot stretched.
- The toes are point towards, and about 5 cm from, the ground.

- (4) On the command—

RIGHT FOOT – FRONT

- The right foot is advanced smartly about 30 cm beyond the left foot.
- The leg is bent sufficiently to enable the foot to clear the ground.
- The leg is straightened as it comes forward.
- The foot is stretched and turned outwards at the same time as when halted.
- The toes are pointed towards, and about 5 cm from, the ground.
- The left leg is kept straight and the body balanced on the left foot.

- (5) On the command (given when the right foot is forward and on the ground)—

HALT

- A full forward pace is completed with the left foot and the right foot brought smartly up in line with the left foot.

b. Marching

- (1) The instructor is to explain and demonstrate each aspect.

- (2) On the command—

SLOW – MARCH

- The left foot is advanced evenly to complete a pace of 60 cm.
- The foot is turned outward at the same angle as when halted.
- The foot stretched.
- The toes pointed towards the ground.
- The arms and hands are kept steady at the side.
- Without pause, a similar pace is taken with the right foot.
- The forward movement continued in slow time.
- The body is well balanced over the thighs.
- Each leg, as it swings forward, is bent sufficiently at the knee to enable the foot to clear the ground.
- After the initial pace of 60 cm, marching continues with 75 cm paces.

- (3) On the command (given when the right foot is forward and on the ground)—

HALT

- A forward pace is completed with the left foot.
- The right foot is brought smartly up in line with the left foot.
- See Figure [1-4-1](#).

- (4) Common faults—

- (a) Looking down.
- (b) Not maintaining alignment.
- (c) Speed of foot coming through too slow.
- (d) Toe/foot angle incorrect, toe pitched upwards/heel down.
- (e) Leaning backwards.
- (f) Over/under-speed. Cadence.

c. Marking time

- (1) On the command (given when the left foot is forward and on the ground)—

MARK – TIME

- A full forward pace is completed with the right foot.
- Marking time will then start on the next beat of the left foot.
- Each foot is raised alternately 225 mm from the ground without moving forward or backward.
- The foot, as it is raised, is pointed downwards.
- The leg (below the knee) is perpendicular to the ground.
- See Figure [1-4-2](#).

- (2) Common faults—

- (a) Looking down.
- (b) Rotating forward or in other directions.
- (c) Arm swing.
- (d) Toe/foot angle incorrect.
- (e) Cadence.



Figure 1-4-2 Position when Marking Time

- (3) On the command (given when the right foot is on the ground)—
HALT
 - One further movement is completed with the left foot.
 - The right foot is brought smartly in line with the left.
 - (4) On the command (given when the left foot is on the ground and the right knee raised)—
FOR – WARD
 - A further movement is completed with the right foot.
 - A slow march is resumed, starting with the left foot.
- d. Changing step when marching
- (1) The instructor is to explain and demonstrate each aspect.
 - (2) On the command (given when the right foot is forward and on the ground)—
CHANGE – STEP
 - A further pace is completed with the left foot.
 - The hollow of the instep of the right foot is brought up in line with the heel of the left foot.
 - The left foot is then moved forward — although the step is changed, the timing is not lost.

e. Changing step when marking time

On the command (given when the right foot is on the ground)—

CHANGE – STEP

- Two successive movements are completed with the left foot.
- Marking time is restarted with the right foot.

f. Variation of pace

(1) On the command (given when the left foot is forward and on the ground)—

STEP – OUT

- A further pace is completed with the right foot.
- The pace is then lengthened to 80 cm, starting with the left foot, without altering the marching time. (This step is used when a slight increase of speed is required without altering the time.)

(2) On the command (given when the left foot is forward and on the ground)—

SLOW – MARCH

- A further 80 cm pace is completed with the right foot.
- The pace is then shortened to 75 cm starting with the left foot.

(3) On the command (given when the left foot is forward and on the ground)—

STEP – SHORT

- A further 75 cm pace is completed with the right foot.
- The pace is then shortened to 50 cm starting with the left foot, without altering the marching time. (This step is used when a slight decrease of speed is required without altering the time.)

(4) On the command (given when the left foot is forward and on the ground)—

SLOW – MARCH

- A further 50 cm pace is completed with the right foot.
- The pace is then lengthened to 75 cm, starting with the left foot.

g. Turnings on the march

(1) The balance step is a useful method of instruction for preliminary training in drill movements, but is only used as an instructional aid. Movements are carried out in slow time when this step is used.

(2) The instructor is to demonstrate each movement and follow this sequence of instruction.

- (3) On the command (given when the left foot is forward and on the ground)—

BALANCE STEP

RIGHT – TURN

- A full forward check pace is completed with the right foot.
- The left foot is turned diagonally to the right and is placed on the ground to complete a block pace, with the instep of the left foot about three inches in front of the right toe. (See Figure [1-4-3](#).)
- The weight of the body is turned to the right.
- At the same time the right foot is advanced smartly about 30 cm in the new direction, and is held clear of the ground with the foot stretched and the toes pointing downwards. (In this position both knees are straight and the arms are held steady at the sides.)



Figure 1-4-3 Position for Block Pace on Right Turn on the March

- (4) On the command—

FOR – WARD

- A forward pace of 75 cm is completed with the right foot.
- Marching is resumed in slow time.

- (5) On the command (given when the left foot is forward and on the ground)—
RIGHT – TURN
- A full forward pace is completed with the right foot.
 - A turn to the right is made by turning the left foot diagonally to the right and placing it on the ground about 75 mm in front of the right toe.
 - The weight of the body is transferred to the left foot.
 - The body turned to the right.
 - The right foot advanced a full forward pace in the new direction.
 - Marching is continued in slow time.
- (6) On the command—
RIGHT IN – CLINE
- The movement is carried out in the same manner as for the right turn except that only a half turn is made.
- (7) On the command (given when the left foot is forward and on the ground)—
ABOUT – TURN
- A full forward pace is completed with the right foot.
 - The body is then turned about to the right by marking time for three slow beats, turning the body progressively with each beat.
 - Marching in slow time is then resumed with the right foot.
- (8) The details for the left turn are the same as for the right, except that the word left is substituted for the word right and vice versa.
- (9) When carrying out turning or inclining on the march in quick time, the movements are the same as for slow time except that the arms are brought smartly into the sides on the check pace and held steady until the arm swing is resumed when stepping off in the new direction.

h. Length of pace in marching.

The length of pace in marching is as shown in Table [1-4-1](#).

| March | Pace length |
|-------------------------------|--------------------|
| Slow march | 75 cm |
| Quick march | 75 cm |
| Sideways march | 30 cm |
| Double march | 1 m |
| Stepping short | 50 cm |
| Stepping out | 80 cm |
| Stepping forward and backward | 75 cm |
| Stepping off | 60 cm |

Chapter 5 – Weapons Drill

1.5.1 Method of instruction

- a. Instructors are to follow the sequence of instruction for every drill contained within this section.
- b. All rifle exercises are taught by numbers.
- c. Movements are made sharp and brisk.
- d. Regulation pauses are counted between each separate movement.
- e. The most common fault in rifle drill is lack of control over the rifle. In rifle exercises, the upper arm and elbow are kept close to the body and there should be no movement of the head or body except where specifically given in this instruction.
- f. The sling when used, should be taut along the left side of the rifle, adjusted with the lower adjustment as close as possible to the lower sling swivel with tension applied via the upper adjustment of the sling.

1.5.2 Armed parades

- a. On armed parades all ranks up to and including flight sergeant (F/S) are to carry rifles irrespective of parade appointment.
- b. The initial stages of arms drill training is given in the 'hollow square'. This method enables the instructor to watch each aviator and correct individual faults.
- c. Exercises are initially taught using 'numbers' then later they are practised by judging the time.
- d. A pause equal to two paces in quick time is observed between movements (movements are at 60 beats to the minute).
- e. Instructors teaching arms drill must continually critique and correct any mistakes.

1.5.3 Position when carrying weapons

- a. When the exercises are carried out, the head, body and legs are kept steady and in the position of attention, except when the detail of the movement states otherwise.
- b. The disengaged arm is kept steady at the side when marching in slow time. When marching in quick time the disengaged arm is swung from front to rear in the same manner as in drill without arms, except where otherwise specified.
- c. When undertaking rifle drill the position of the sliding butt of the rifle is to be fully closed.

1.5.4 Rifle positions

a. Attention

(1) Teaching points—

- (a) The normal position of attention is maintained, except that the rifle is held in the right shoulder.
- (b) The right arm fully extended with the fingers curled gripping the pistol grip.
- (c) The rifle is pulled back with the right hand so that the thumb is touching the leg level with the seam of the trousers.
- (d) See Figure [1-5-1](#).

(2) Common faults—

- (a) Hand grip/position on the pistol grip.
- (b) Angle of rifle.
- (c) Dropping of right shoulder.



Figure 1-5-1 Position of Attention



Figure 1-5-2 1st Position of Stand at Ease

b. Stand at ease

- (1) On the command—

STAND AT EASE

BY NUMBERS – ONE

- The butt is forced forward with the right hand so that the rifle is vertical.
- The left hand is brought across the body by the shortest route to seize the barrel at the hand guard with the fingers and thumb wrapped around it.
- See Figure [1-5-2](#).

- (2) On the command—

BY NUMBERS – TWO

- While maintaining control of the rifle with the left hand, the right hand strikes the butt between the magazine and the toe of the butt, with fingers and thumb together.
- The right arm is kept straight and close to the body.
- See Figure [1-5-3](#).



Figure 1-5-3 2nd Position of Stand at Ease

- (3) On the command—
- BY NUMBERS – THREE**
- The left knee is bent and the foot driven out 30 cm to the left.
 - The rifle barrel is forced down to the full extent of the left arm.
 - The right hand cups the butt of the rifle behind the pistol grip with the fingers and thumb together.
 - The body is kept evenly balanced on both feet with the rifle held in a horizontal position across the front of the body, parallel to the ground.
 - See Figure [1-5-4](#).



Figure 1-5-4 3rd Position of Stand at Ease

- (4) Common faults—
 - (a) Coordination between hands/rifle movements.
 - (b) Positioning of fingers/hands.
 - (c) Positioning of elbow on second movement.
 - (d) Positioning of hand and fingers on second movement.
 - (e) Looking down.
 - (f) Rifle not parallel to the ground.
 - (g) Gap between heels.
 - (h) Lack of punch and precision.
 - (5) Practice is to be conducted individually, then as a group.
- c. Stand easy
- (1) On the command 'STAND EASY', relax the body.
 - (2) There is no talking.
 - (3) The feet are not to be moved.

- d. Stand at ease from stand easy
- (1) On the precautionary word of command, for example 'FLIGHT', the body is braced and the at ease position resumed.
- e. Shoulder arms from the stand at ease position
- (1) The shoulder arms from the stand at ease position is carried out in two movements.
- (2) On the command—

ATTENTION BY NUMBERS – ONE

- The left knee is bent and the left foot is driven in 30cm as per the normal position of attention.
- At the same time the rifle is forced to a vertical position at the side of the body while retaining the hold on the hand guard with the left hand, and the right hand holds the pistol grip.
- See Figure [1-5-5](#).



Figure 1-5-5 1st Position of Shoulder Arms

- (3) On the command—

BY NUMBERS – TWO

- Cut the left hand away to the side of the body by the shortest route to the position of attention. Close the hand on the way down and at the same time pull the rifle back with the right hand so that the thumb is touching the leg, level with the seam of the trousers.
- Practice is to be conducted individually, then as a group.
- See Figure [1-5-6](#).



Figure 1-5-6 2nd position of Shoulder Arms

- f. Saluting with the rifle
- (1) The instructor is to provide the context for learning by revising why personnel pay compliments, the origins of saluting and appropriate related protocols.
 - (2) Saluting can be individual, by flights or squadrons in various ceremonial occasions.

1.5.5 Salute at the shoulder arms

- a. The salute at the halt with a rifle is carried out from the shoulder arms position. It is carried out in two movements. The actions are the same when saluting to the front or the flank, except that the head and eyes are turned at the commencement of a salute to the flank and then to the front at the completion of the salute.

UNCLASSIFIED

NZAP 2.4 Manual of Ceremonial and Drill
Part 1 – Foot and Weapons Drill
Chapter 5 - Weapons Drill

Version 6.00
13 June 2023

(1) On the command—

TO THE FRONT SALUTE

BY NUMBERS – ONE

- Force the butt forward with the right hand so that the rifle is vertical.
- At the same time force the left hand across the body.
- Strike the hand guard with the palm of the hand.
- Extend fingers and thumb.
- Keep the left elbow held close to the body.
- See Figure [1-5-7](#).



Figure 1-5-7 Position of Saluting to the Front

(2) On the command—

BY NUMBERS - TWO

- Cut the left hand away to the side of the body by the shortest route to the position of attention, (closing the hand on the way down and at the same time pull the rifle back with the right hand so that the thumb is touching the leg level with the seam of the trousers).

(3) Common faults—

- (a) Forearm not parallel.
- (b) Cupping of fingers.

UNCLASSIFIED

- (c) Butt not pushed forward.
 - (d) Lack of precision on last movement.
 - (e) No coordination between rifle and left arm.
 - (f) Left hand does not return to correct position at attention.
- (4) Practice is to be conducted individually, then as a group.

1.5.6 Present arms from the shoulder arms

- a. The instructor is to explain the ceremonial significance of the general salute on parades, give examples of when it is used and revise the origins of saluting. The present arms from the shoulder arms is carried out in two movements.

- (1) On the command—

PRESENT ARMS

BY NUMBERS – ONE

- The rifle is forced forward with the right hand to a central position in front of the body with the barrel vertical and the optic sight close to the body, right arm fully extended gripping the pistol grip.
- At the same time the left hand seizes the hand guard with fingers together and thumb extended up the side, parallel with the barrel. The thumb must not protrude above the hand guard.
- The elbows are kept to the side of the body.
- See Figure [1-5-8](#).



Figure 1-5-8 1st Position of the Present from the Shoulder

(2) On the command—

BY NUMBERS – TWO

- Move the right hand to the extension point on the butt of the rifle, with the thumb and fingers either side gripping just below the pistol grip. The fingers should be together and the arm fully extended with the wrist straight.
- At the same time bend the right knee and drive the foot down so that the instep is behind and touching the heel of the left foot, while still retaining the same angle of the feet.
- See Figure [1-5-9](#).



Figure 1-5-9 2nd Position of the Present from the Shoulder

- (3) Common faults—
- (a) Rifle not centred on the body.
 - (b) Left hand incorrectly placed.
 - (c) Left thumb too high on the hand guard.
 - (d) Right hand spread too wide.
 - (e) Rifle not vertical.
 - (f) Positioning of right foot, not back far enough, not placed in heel of left foot etc.

1.5.7 Shoulder arms from the present arms

- a. The shoulder arms from the present arms is carried out in two movements.

- (1) On the command—

SHOULDER ARMS BY NUMBERS – ONE

- The rifle is forced to the shoulder arms position with the left hand, rifle vertical.

- At the same time transfer the right hand to the correct position for the shoulder arms (as for the first position of the shoulder arms from the stand at ease).
- (2) On the command—
- BY NUMBERS – TWO**
- The right knee is bent.
 - The right foot driven in beside the left into the position of attention.
 - At the same time, the rifle back is pulled back with the right hand so that the thumb is touching the leg, level with the seam of the trousers.
- (3) Common faults—
- (a) Incorrect hand placement.
 - (b) Right foot not driven in with punch/precision.

1.5.8 Ground arms, take up arms and change arms

- a. This drill can be used when an unarmed drill is to be taught or, to give personnel a break from carrying the weapon. The change arms is used to give the arm and shoulders a rest while carrying the weapon for long periods.
 - b. Ground arms
 - (1) The ground arms is carried out in four movements.
 - (a) On the command—
- GROUND ARMS**
- BY NUMBERS – ONE**
- The butt is forced forward with the right hand until the rifle is vertical and the left hand brought smartly across the body to seize the hand guard (this is the same as for the first movement of the stand at ease from the shoulder).
 - See Figure [1-5-10](#).



Figure 1-5-10 1st Position of the Ground Arms

(b) On the command—

BY NUMBERS – TWO

- With the right hand, grip the weapon above the magazine and below the left hand.
- See Figure [1-5-11](#).

UNCLASSIFIED



Figure 1-5-11 2nd Position of the Ground Arms

(c) On the command—

BY NUMBERS – THREE

- The left foot is driven forward 60cm.
- At the same time cut the left arm to the side and kneel down, keeping the knee off the ground.
- The rifle is placed on the ground, muzzle to the front, magazine to the right, with the optic sight in line with the right foot and level with the left foot.
- The other rank (OR) bends their neck forward to observe the positioning of the rifle.
- The left arm is kept straight beside the body.
- See Figure [1-5-12](#).

UNCLASSIFIED



Figure 1-5-12 3rd Position of the Ground Arms

(d) On the command—

SHUN

- The right hand is to release the rifle and the body forced upright to resume the position of attention.
- See Figure [1-5-13](#).



Figure 1-5-13 4th Position of the Ground Arms

c. Take up arms

(1) The take up arms is carried out in four movements.

(a) On the command—

TAKE UP ARMS

BY NUMBERS – ONE

- The left foot is driven forward 60 cm.
- At the same time, the rifle is gripped with the right hand part way up the hand guard.
- The left arm is kept straight at the side of the body and the neck is bent forward to observe the correct grip with the right hand.
- See Figure [1-5-14](#).



Figure 1-5-14 1st Position of the Take Up Arms

(b) On the command—

BY NUMBERS – TWO

- Force the body upright to resume the position of attention.
- At the same time bring the rifle to a vertical position at the right side of the body.
- At the same time drive the left hand across the body to seize the hand guard as for the second movement of the ground arms.
- See Figure [1-5-15](#).



Figure 1-5-15 2nd Position of the Take Up Arms

(c) On the command—

BY NUMBERS – THREE

- Move the right hand down to take the weight of the rifle with the pistol grip.
- See Figure [1-5-16](#).



Figure 1-5-16 3rd Position of the Take Up Arms

(d) On the command—

BY NUMBERS – FOUR

- Cut the left hand away to the side, and at the same time pull the right hand back to adopt the shoulder arms position.
- See Figure [1-5-17](#).



Figure 1-5-17 4th Position of the take Up Arms

- d. Change arms at the halt.
- (1) It is important that armed personnel are given regular change arms to relieve the strain of carrying the weapon at the shoulder. The load bearing arm can be changed every 10-15 minutes in order to rest the arm and shoulder. The change arms is taught at the halt in the first instance and carried out in four movements.
- (a) On the command—
- CHANGE ARMS**
- BY NUMBERS – ONE**
- With the right hand, force the rifle to a central position about 15cm in front of the body with the barrel vertical and the right arm fully extended holding the pistol grip.
 - At the same time strike and seize the hand guard at its top with the left hand, keeping the elbows close to the sides.
 - See Figure [1-5-18](#).



Figure 1-5-18 1st Position of the Change Arms at the Halt

(b) On the command—

BY NUMBERS – TWO

- Release the grip of the right hand and strike and seize the hand guard immediately below the left hand.
- See Figure [1-5-19](#).



Figure 1-5-19 2nd Position of the Change Arms at the Halt

(c) On the command—

BY NUMBERS – THREE

- With the right hand force the rifle to the shoulder position at the left side, barrel vertical.
- At the same time the left hand seizes the pistol grip.
- See Figure [1-5-20](#).



Figure 1-5-20 3rd Position of the Change Arms at the Halt

(d) On the command—

BY NUMBERS – FOUR

- The right hand is cut to the side and the rifle is pulled back.
- See Figure [1-5-21](#).



Figure 1-5-21 4th Position of the Change Arms at the Halt

- (2) To change arms back from the left to the right side the process is reversed (change left hand to read right hand etc).
- e. Change arms on the march.
- (1) The executive word of command is received as the left foot strikes the ground.
 - (2) The four movements are carried out as described in paragraph [1.5.12](#) on successive beats of the left foot and the rifle is held still on each beat of the right foot.
 - (3) A check pace is taken at the beginning of this drill movement, during which the swinging arm should be kept still and by the side in the same way as for the salute on the march.

1.5.9 Fix and unfix bayonets

- a. This drill is likely to be taught as a lead-in to a pending ceremonial event. Many armed parades require bayonets fixed and the following drill provides that in a formal manner. The drill is often performed informally as part of weapon issue and is not normally carried out as part of the ceremony unless a belt with a bayonet frog is worn. The command to fix bayonets is given with the rifle in the shoulder arms position and is carried out in three stages.

b. Fixing bayonets

(1) On the command—

FLIGHT/SQUADRON WILL FIX BAYONETS

FIX

- The left elbow is bent and the left hand placed between the body and the bayonet handle with the handle resting in the palm of the hand.
- After a regulation pause the bayonet is removed from the scabbard.
- The bayonet is now held horizontally below the left buttock with the cutting edge downward, the back of the left hand is touching the back of the left leg, fingers curled around the bayonet handle.
- Neither hand nor bayonet should be visible from the front.

(2) On the command—

BAYONETS

- The bayonet is brought across with the left arm and placed onto the rifle by fitting the bayonet ring over the flash suppressor.
- At the same time the head and eyes are turned to the right to observe the bayonet fixing.
- The bayonet is then pushed down until the catch is engaged.
- The left hand is then moved out forward of the handle approximately 15 cm and then strikes the bayonet handle.
- The forearm and wrist should be straight, with the fingers and thumb together and the thumb along the crosspiece/guard of the bayonet.
- The left elbow is pulled in close against the chest.

(3) On the command—

SHUN

- The left hand is cut away to the side and the head and eyes turned to the front to resume the position of attention with the rifle at the shoulder.

c. Unfixing bayonets

Command to unfix bayonets is given with the rifle in the shoulder arms position and is carried out in three stages.

(1) On the command—

FLIGHT/SQUADRON WILL UNFIX BAYONETS—

UNFIX

- The rifle is forced to a central position in front of the body with the barrel vertical and the right arm fully extended while holding the pistol grip (as for the first movement of the present arms).
- At the same time, grasp the barrel as high as possible with the left hand, underneath the bayonet handle.

UNCLASSIFIED

NZAP 2.4 Manual of Ceremonial and Drill
 Part 1 – Foot and Weapons Drill
 Chapter 5 - Weapons Drill

Version 6.00
 13 June 2023

- The rifle is then forced downwards with the left hand to a position between the knees.
- The head and eyes are tilted down to observe the movement, and the right hand is removed from the pistol grip to grasp the bayonet handle above the left hand.
- The bayonet release catch is depressed with the index finger and thumb of the left hand and the bayonet removed 3cm clear of the rifle with the right hand.

(2) On the command—

BAYONETS

- The head and eyes are turned to the left to look down at the hip and at the same time the right hand forces the bayonet across to the left to strike the flat of the blade against the waist belt.
- The left hand grasps the scabbard and the bayonet is forced home.
- This position is maintained until the next command is given.

(3) On the command—

SHUN**BY NUMBERS – ONE**

- The left hand quits the scabbard and is forced round to grasp the hand guard.
- At the same time the right hand is whipped back to the right side of the body.
- The head and eyes turned to the front.

(4) On the command—

BY NUMBERS – TWO

- The body and legs are straightened up.
- The rifle lifted into the right side with the left hand.
- The right hand grasps the pistol grip when the rifle reaches the shoulder, as with the shoulder arms position.

(5) On the command—

BY NUMBERS – THREE

- The left arm is cut to the side and the rifle pulled back with the right hand to assume the shoulder arms position.

1.5.10 On guard drill for QC/SqnS parties

- a. The on guard position is used by QC/SqnS escorts when QC/SqnSs are being cased/uncased.

- (1) The bearer gives the command—

**CASE/UNCASE THE QUEEN’S COLOUR/SQUADRON STANDARD
BY NUMBERS – ONE**

- The escorts execute an outwards turn (right/left incline), pause then carry out the following movements—
 - The hand guard is struck and seized with the left hand, fingers and thumb curled around the rifle with the wrist straight.

- (2) The bearer gives the command—

BY NUMBERS – TWO

- The next movements are done simultaneously—
 - The left knee is bent, the left foot raised and placed smartly 40 cm directly in front of the body.
 - The body is inclined slightly forward to facilitate an even weight distribution over both feet.
 - The rifle is forced forward and downwards to a position of 45° angle in front of the right shoulder.
 - The left arm is slightly bent.
 - The right hand grasps the pistol grip and the forefinger placed outside the trigger guard.
 - The butt of the rifle is forced into the side between forearm and body.
 - See Figure [1-5-22](#).



Figure 1-5-22 Final position of the On Guard Position

- b. Shoulder from the on guard.
- (1) On the command—
ESCORTS
SHOULDER ARMS
BY NUMBERS – ONE
 - The left knee is bent, the foot raised and placed sharply back to assume the normal position of attention.
 - The rifle is forced back into the shoulder, the grip of the right hand changing to its correct position holding the pistol grip.
 - (2) On the command—
BY NUMBERS – TWO
 - The left hand is cut to the side of the body and the rifle pulled back to resume the position of attention.
 - (3) On the command—
BY NUMBERS – THREE
 - The escorts execute right/left inclines to face the front and assume their normal positions.

1.5.11 Rifle drill for funerals

- a. This section is devoted entirely to funeral/memorial drills that are arranged in the order they are to be taught. Given these are tri-Service drills, examples given are represented by all three Services. The rifle drills are performed at military funerals and on some ceremonial occasions, eg Anzac Day. There may be slight variations to procedures at some funerals because of the following factors—
- (1) The wishes of the next-of-kin (NOK).
 - (2) The type of funeral, where space may be a limiting factor at either—
 - (a) cemetery;
 - (b) crematorium; or
 - (c) church.
- b. To assist in performing accurate drills the sequence is to be followed and rehearsed often.
- c. To add more solemnity to the occasion, the rifle drill should be performed to the beat of a drum. All movement carried out to eight beats of slow time are done to the 'drum roll'. Single movements are done to a single tap on the drum.

1.5.12 Reverse arms from the shoulder arms

- a. This drill is used to place the weapon in a submissive position as a mark of respect before marching into a place of parade or as part of the procedure during a ceremony.

On the commands—

REVERSE ARMS**BY NUMBERS – ONE**

- With the right hand being retained on the pistol grip, force the rifle to the centre of the body.
- At the same time the left arm is forced across the body to take an all-round grip of the hand guard just above the magazine.
- See Figure [1-2-23](#).



Figure 1-5-23 1st Position of the Reverse Arms

BY NUMBERS – TWO

- The rifle is rotated forward to face the rear, finishing under the right armpit.
- At the same time the right hand is transferred from the pistol grip to take an all-round grip of the small of the butt.
- The rifle is at a 45° angle.
- See Figure [1-5-24](#).



Figure 1-5-24 2nd Position of the Reverse Arms

BY NUMBERS – THREE

- The left hand is transferred smartly to the optical sight with the thumb in line with the optical sight.
- The tip of the thumb in line with the end of the optical sight.
- See Figure [1-5-25](#).



Figure 1-5-25 3rd Position of the Reverse Arms

1.5.13 Shoulder arms from reverse arms

- a. This drill movement is used to return to a basic position of readiness prior to marching off or completing another movement.
- b. The instructor is to explain and demonstrate the complete movement.
- c. Teaching by numbers demonstrates and explains that on the command—

SHOULDER ARMS

BY NUMBERS – ONE

- The right hand maintains its grip on the small of the butt and the rifle is allowed to swing down barrel first to a vertical position.
- At the same time the left hand grasps the hand guard with the tip of the thumb as close as possible to the top of the hand guard.
- The back of the left hand should face the ground.
- See Figure [1-5-26](#).



Figure 1-5-26 1st Position of the Shoulder Arms from the Reverse Arms

BY NUMBERS – TWO

- The rifle is rotated forward with the left hand until the barrel is vertical and under the right armpit.
- As the butt of the weapon passes beneath the right shoulder transfer the right hand to the pistol grip.
- See Figure [1-5-27](#).



Figure 1-5-27 2nd Position of the Shoulder Arms from the Reverse Arms

Common fault—

- Weapon released too early when rotating.

BY NUMBERS – THREE

- The left arm is cut away to the left side of the body and the rifle is pulled back to assume the position of attention.
- See Figure [1-5-28](#).



Figure 1-5-28 3rd Position of the Shoulder Arms from the Reverse Arms

1.5.14 Present arms from reverse arms

- a. Form the squad into a hollow square.

On the commands—

PRESENT ARMS

BY NUMBERS – ONE

- The right hand maintains its grip on the small of the butt.
- The rifle is pivoted downward so it is perpendicular to the ground, with the forearm parallel to the ground.
- The elbow remains locked to the side of the body.
- At the same time the left hand is moved sharply from the optical sight to the hand guard, ensuring the thumb is running parallel to the rifle with the tip of the thumb facing down in line with the top of the hand guard.
- The back of left hand should be facing the centre of the body.
- See Figure [1-5-29](#).



Figure 1-5-29 1st Position of the Present Arms from the Reverse Arms

Common faults—

- Weapon not held perpendicular to the ground.
- Forearm is not parallel to the ground.
- Left hand is not cut away sharply.
- Elbow of the right arm is not locked in against the body.
- Body is twisted during the movement.
- Shoulders are not kept square to the front.
- Weapon is lowered during the movement.
- Left hand is not driven forward to grasp the hand guard, with the palm facing forward.

On the commands—

PRESENT ARMS

BY NUMBERS – TWO

- The rifle is rotated forward with the left hand until the barrel is uppermost, and in the centre of the body.
- At the same time the right hand pivots with the weapon to seize the pistol grip, as for the first position of present arms.
- The left hand maintains its grip on the hand guard and the thumb is extended up the barrel, with the top of the digit level with the top of the hand guard.

- At the same time, the right foot is driven behind the left foot, with the right instep behind the left heel, and the left hand cups the weapon to the rear of the pistol grip in the same position as for the present arms.
- See Figure [1-5-30](#).

Common faults—

- Rifle is moved from the perpendicular or allowed to wobble during the movement.
- Thumb of the left hand is not level with the top of the barrel grip.
- The right foot is not driven behind the left.



Figure 1-5-30 2nd Position of the Present Arms from the Reverse Arms

1.5.15 Change arms from reverse arms

- a. This drill would be used if a funeral procession is required to march a long distance, and enables personnel to rest their shoulders.

Note: When demonstrating the change arms on the march, march so to give a full view of the movement and demonstrate in Slow March the first time.

On the command—

**CHANGE ARMS
 BY NUMBERS – ONE**

- Holding the rifle at the small of the butt with the right hand, allow the muzzle to swing forward so that the muzzle is pointing downward and aligned with the centre of the body.
- At the same time transfer the left hand from the optical sight and take an all-round grip with the right hand.
- See Figure [1-5-31](#).



Figure 1-5-31 1st Positions of the Change Arms at the Reverse

BY NUMBERS – TWO

- Force the rifle under the left armpit with the left hand.
- At the same time transfer the right hand to the optical sight using an underhand grip with thumb in line with the optical sight.
- The tip of thumb should be in line with the end of the optical sight.
- The back of the right hand is facing towards the ground.
- See Figure [1-5-32](#).



Figure 1-5-32 2nd Position of the Change Arms at the Reverse

Common fault—

- Butt held too low causing the rifle to be nearly horizontal.
- b. Explain to the squad that the executive word of command is received as the left foot strikes the ground. The two movements are carried out on successive beats of the left foot. The rifle is held still on the beats of the right foot.
 - c. Practice the squad in change arms on the march in slow and quick time by giving the command 'SQUAD CHANGE - ARMS'.
 - d. The squad is to call the time 'check', 'one', 'two', 'three' in slow time and 'check', 'one', 'two', 'three', 'swing' in quick time on the beats of the left foot.

1.5.16 Lower on arms reverse from reverse arms

- a. This drill is used for both funeral and catafalque parties. It is carried out only from a position when the rifle is under the right shoulder.

On the commands—

LOWER ON ARMS REVERSE BY NUMBERS – ONE

- Maintain the grip with the right hand; lower the muzzle until vertical, magazine towards the body in front of the right shoulder.

UNCLASSIFIED

NZAP 2.4 Manual of Ceremonial and Drill
 Part 1 – Foot and Weapons Drill
 Chapter 5 - Weapons Drill

Version 6.00
 13 June 2023

- At the same time, grasp the butt with the left hand, fingers running down the right side and thumb along the butt towards the toe, back of the hand uppermost, left elbow into the body.
- See Figure [1-5-33](#).

Common faults—

- Looking down.
- Elbow not kept locked into side.
- Leaning forward.



Figure 1-5-33 1st Position of the Lower on Arms Reverse from the Reverse Arms

BY NUMBERS –TWO

- Take the weight of the rifle with the left hand; transfer the right hand from the small of the butt to the pistol grip with the index finger outside the trigger guard.
- At the same time, smartly force the rifle straight down to the full extent of the right arm.
- See Figure [1-5-34](#).

Common fault—

- Head leaning to the right or left.

UNCLASSIFIED



Figure 1-5-34 2nd Position of the Lower on Arms Reverse from the Reverse Arms

BY NUMBERS – THREE

- Lower the head to the count of three beats in slow time until the eyes look at the ground two metres to the front.
- The head should be roughly at a 45° angle.

Practice the squad in calling and judging the time for all three movements.

Common fault—

- Eyes moving down, but not the head—keep eyes straight and lower the head.

1.5.17 Reverse arms from lower on arms reverse

- a. Personnel must be brought to the position of attention before this drill.

On the command—

GUARD

GUARD – SHUN

- The head is raised smartly.

On the command—

REVERSE ARMS

BY NUMBERS – ONE

- Controlling the weight of the weapon with the left hand, pivot the right hand from the pistol grip to form an all-round grip on the small of the butt.
- Keep the back of the hand facing outer most.
- See Figure [1-5-35](#).

Common faults—

- Not finding the small of the butt.
- Lifting weapon.
- Right elbow not tucked into body.
- Right shoulder dropping.
- Temptation to look down.



Figure 1-5-35 1st Position of the Reverse Arms from the Lower On Arms Reverse

BY NUMBERS – TWO

- Force the rifle under the right armpit with the right hand at the same time cut the left hand to the optical sight with the thumb in line with the optical sight. The tip of the thumb in line with the end of the optical sight.
- See Figure [1-5-36](#).



Figure 1-5-36 2nd Position of the Reverse Arms from the Lower On Arms Reverse

Common faults—

- The back of the left hand is facing towards the ground.
- Thumb not in line with the end of the optical sight.

1.5.18 Shoulder Arms from Lower On Arms Reverse

- a. Personnel must be brought to the position of attention prior to this drill. Demonstrate the complete movement.

On the command—

GUARD

GUARD – SHUN

- The head is raised smartly.

On the command—

SHOULDER ARMS

BY NUMBERS – ONE

- With the right hand raise the rifle, rotate the barrel forward and to the centre of the body.
- At the same time transfer the left hand from the butt plate to grasp the hand guard with an all-round grip, at the same level as for the present arms.
- See Figure [1-5-37](#).

UNCLASSIFIED

NZAP 2.4 Manual of Ceremonial and Drill
Part 1 – Foot and Weapons Drill
Chapter 5 - Weapons Drill

Version 6.00
13 June 2023

Common faults—

- Rifle not high enough.
- Arms splayed from the body.



Figure 1-5-37 1st Position of the Shoulder Arms from the Lower On Arms Reverse

BY NUMBERS – TWO

- Force the rifle across the body and under the right armpit.
- The rifle should remain at the vertical.
- At the same time transfer the right hand from the trigger guard to the pistol grip.
- See Figure [1-5-38](#).

Common faults—

- Rifle not high enough.
- Rifle not perpendicular.

UNCLASSIFIED



Figure 1-5-38 2nd Position of the Shoulder Arms from the Lower On Arms Reverse

BY NUMBERS – THREE

- Cut the left arm to the side of the body and smartly draw the rifle to the attention position (thumb in line with the seam of the trousers).
- See Figure [1-5-39](#).



Figure 1-5-39 3rd Position of the Shoulder Arms from the Lower On Arms Reverse

1.5.19 Present arms from the lower on arms reverse

On the command—

GUARD

GUARD – SHUN

- The head is raised smartly.

Teaching by numbers demonstrates and explains that on the command—

PRESENT ARMS

BY NUMBERS – ONE

- With the right hand raise the rifle rotating the barrel forward and to the centre of the body.
- At the same time transfer the left hand from the butt plate to grasp the hand guard with the thumb in line with top.
- See Figure [1-5-40](#).

Common fault—

- Rifle not in the centre of the body.

UNCLASSIFIED

NZAP 2.4 Manual of Ceremonial and Drill
Part 1 – Foot and Weapons Drill
Chapter 5 - Weapons Drill

Version 6.00
13 June 2023



Figure 1-5-40 1st Position of the Present Arms from the Lower On Arms Reverse

BY NUMBERS – TWO

- Transfer the right hand from the trigger guard to the stock behind the pistol grip.
- At the same time stamp the right foot instep into the left heel.
- See Figure [1-5-41](#).

Common fault—

- Right foot and arm are not moving in unison.

UNCLASSIFIED



Figure 1-5-41 2nd Position of the Present Arms from the Lower On Arms Reverse

1.5.20 Lower on arms reverse from the present arms

This drill is used to return to or adopt a passive position of respect at an appropriate event.

On the command—

**LOWER ON YOUR ARMS REVERSE
BY NUMBERS – ONE**

- Transfer the right hand from the butt plate to the pistol grip with forefinger vertical outside the trigger guard.
- At the same time bring the right heel in line with the left, stamping the foot as for the attention position.
- See Figure [1-5-42](#).

Common fault—

- Looking down.



Figure 1-5-42 1st Position of the Lower on Arms Reverse from the Present

BY NUMBERS - TWO

- Rotate the rifle 180° in front of the body, and move it to the right hand side of the body under control of the right hand.
- At the same time the left hand is transferred to the butt plate, fingers down the right side and thumb down the left.
- See Figure [1-5-43](#).

Common fault—

- Right elbow not being kept close to the body.

UNCLASSIFIED

NZAP 2.4 Manual of Ceremonial and Drill
Part 1 – Foot and Weapons Drill
Chapter 5 - Weapons Drill

Version 6.00
13 June 2023



Figure 1-5-43 2nd Position of the Lower on Arms Reverse from the Present

BY NUMBERS – THREE

- Smartly force the rifle straight down to the full extent of the right arm.
- See Figure [1-5-44](#).

Common faults—

- Head leaning to the right or left.
- Elbow not tucked into the body.

UNCLASSIFIED



Figure 1-5-44 3rd Position of the Present from the Lower On Arms Reverse

BY NUMBERS – FOUR

- Lower the head to the count of three beats in slow time until the eyes look at the ground 2 m to the front.
- The head should be roughly at a 45° angle.
- See Figure [1-5-45](#).



Figure 1-5-45 4th Position of the Present from the Lower On Arms Reverse

1.5.21 Lower on arms reverse from the shoulder arms

This movement ends with the weapon placed in a solemn, passive position.

On the command—

LOWER ON ARMS REVERSE

BY NUMBERS – ONE

- The rifle is moved sharply out to the centre of the body, barrel vertical and hand guard level with the eyes.
- The optic sight should be as close as possible to the body with the right arm fully extended.
- At the same time the left hand strikes and grasps the hand guard with an all-round grip.
- See Figure [1-5-46](#).

Common fault—

- Rifle not straight/perpendicular to the ground.



Figure 1-5-46 1st Position of the Lower On Arms from the Shoulder Arms

BY NUMBERS – TWO

- The grip of the right hand is rotated so that the index finger is outside the trigger guard running parallel with the barrel and the other fingers are wrapped around the front of the grip.
- Both elbows are kept close to the body.

BY NUMBERS – THREE

- Rotate the rifle forwards 180° in front of the body and move it to the right hand side under control of the right hand, forcing the rifle to the vertical position in front of the right shoulder.
- At the same time the left hand is transferred to the butt plate, fingers down the right side and thumb down the left.
- The left forearm should be parallel to the ground.
- See Figure [1-5-47](#).



Figure 1-5-47 3rd Position of the Lower On Arms from the Shoulder Arms

BY NUMBERS –FOUR

- Smartly force the rifle straight down to the full extent of the right arm.
- See Figure [1-5-48](#).

Common faults—

- Head leaning to the right or left.
- Elbows not well into the body.



Figure 1-5-48 4th Position of the Lower On Arms from the Shoulder Arms

BY NUMBERS – FIVE

- Lower the head to the count of three beats in slow time until the eyes look at the ground 2 m to the front.
- The head should be roughly at a 45° angle.
- See Figure [1-5-49](#).



Figure 1-5-49 5th Position of the Lower On Arms from the Shoulder Arms

1.5.22 Change arms at the lower on arms reverse

This movement is used to provide for relief during any lengthy vigil.

On the command—

GUARD – SHUN

- The head and eyes are raised smartly.

Teaching by numbers demonstrates and explains the drill.

On the commands—

CHANGE ARMS

BY NUMBERS – ONE

- Transfer the rifle to the centre of the body, under control of the right hand, and 5 cm clear of the body.
- At the same time the left hand is transferred from the butt plate to an all-round grip on the pistol grip, index finger outside the trigger guard.

Common faults—

- Rifle is not held straight and in the centre of the body.
- Elbows not held into the side of the body.
- Rifle is not transferred into the left hand.

- Fingers inside trigger guard.

BY NUMBERS – TWO

- Transfer the rifle to the left side of the body in a vertical position.
- At the same time transfer the right hand to the butt plate, back of the hand upper most, fingers down left side of the butt and thumb down the right.

Common faults—

- Rifle is not in the vertical position.
- The right forearm not parallel to the ground.

BY NUMBERS – THREE

- Force the rifle down the left side of the body to the full extent of the left arm.

BY NUMBERS – FOUR

- Lower the head to the count of three beats in slow time until the eyes look at the ground 2 m to the front.

Common faults—

- Head leaning to the left or right.
- Elbows not kept into the side of the body.

1.5.23 Breaking into quick time from slow march at the reverse arms and halting in quick time at the reverse

- a. Changes in cadence will be adopted for the sake of convenience at the conclusion of or before assembly at a place of parade. They will also be introduced to provide some relief from long periods of marching at the same cadence.

- b. On the command, given on two consecutive beats of the right foot —

QUICK – MARCH

- As the next left foot comes to the ground, the left hand releases its grip of the rifle and is brought to the left side of the body.
- At the same time, the rifle is lowered to the full extent of the right arm with the rifle horizontal.
- As the next consecutive right foot hits the ground the left arm is swung and the quick march is commenced.

- c. On the command, given on two consecutive beats of the right foot —

SLOW – MARCH

- As the next left foot comes to the ground at a slow march pace, the rifle is brought up under the armpit to the position of reverse arms and the left hand grasps the optical sight.

- d. On the command, given on two consecutive beats of the right foot —

HALT (QUICK TIME)

- A check pace is taken with the left foot, as the right foot is brought up and driven down beside the left, as for the position of attention.
- At the same time, the rifle is brought up under the right armpit and the left hand is brought smartly across to the correct position of the reverse arms.

1.5.24 Firing volleys

a. Serial 1

On the command—

BY NUMBERS

VOLLEYS WITH BLANK CARTRIDGES – LOAD

SQUAD ...ONE

- From the shoulder arms position, force the butt of the rifle forward.
- At the same time bring the left hand across the body and grip the hand guard towards of the front of the barrel with the thumb running parallel with the barrel.
- The left forearm should be parallel to the ground.
- See Figure [1-5-50](#).



Figure 1-5-50 1st Position of the Firing of Volleys

b. Serial 2

On the command—

SQUAD ...TWO

- Place the left foot firmly on the ground 40 cm directly to the front of the body balanced evenly on both feet.
- At the same time, force the rifle downward and forward with the left hand, and bend the right arm until the rifle is held in front of the right shoulder at a 45o angle. The muzzle should be at eye level and the rifle butt pressed firmly between the body and the right forearm.
- As the rifle is forced to this position change the grip of the right hand so that the forefinger is outside the trigger guard.
- See Figure [1-5-51](#).

Common faults—

- Moving the head.
- Rifle at an incorrect angle.
- Leaning backward.



Figure 1-5-51 2nd Position of the Firing of Volleys

c. Serial 3

On the command—

SQUAD ...THREE

- Glance down without moving the head, remove the left hand from the fore grip, and grasp the cocking handle middle finger and index finger either side of centre.
- See Figure [1-5-52](#).



Figure 1-5-52 3rd Position of the Firing of Volleys

d. Serial 4

On the command—

SQUAD ...FOUR

- Pull the cocking lever to the rear and hold open.
- See Figure [1-5-53](#).



Figure 1-5-53 4th Position of the Firing of Volleys

e. Serial 5

On the command—

SQUAD ...FIVE

- Release the cocking lever, then push the cocking handle fully forward and leave the left hand on the returned cocking handle.
- See Figure [1-5-54](#).

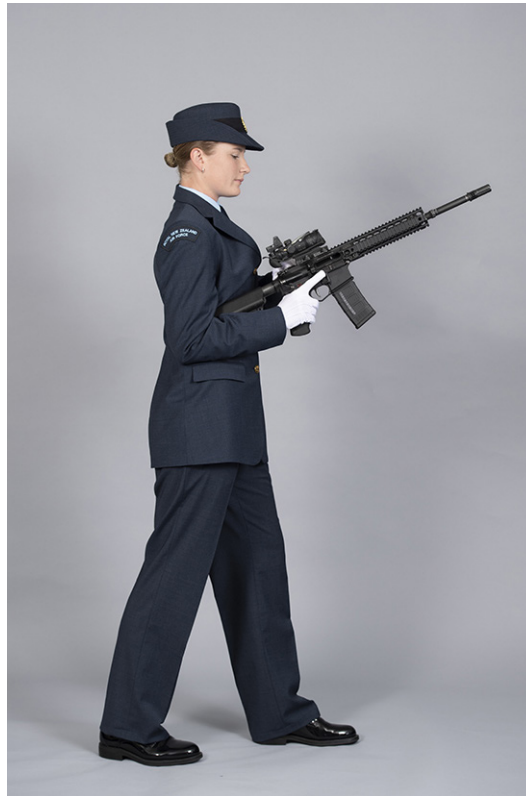

Figure 1-5-54 5th Position of the Firing of Volleys

f. Serial 6

On the command—

SQUAD ...SIX

- Return the left hand to the hand guard.
- See Figure [1-5-55](#).



Figure 1-5-55 6th Position of the Firing of Volleys

g. Serial 7

On the command—

PRESENT

- Raise the rifle placing the butt on the right shoulder with the rifle at an elevation of 45° angle.
- The forefinger is now placed inside the trigger guard (without pressure).
- The left hand is transferred from the hand guard to the base of the pistol grip, fingers together and extended up the trigger guard.
- See Figure [1-5-56](#).

Common faults—

- Applying pressure to the trigger.
- Leaning back.



Figure 1-5-56 7th Position of the Firing of Volleys

h. Serial 8

On the command—

FIRE

- Squeeze the trigger (first pressure only).
- See Figure [1-5-57](#).

Common fault—

- Firing is instantaneous.



Figure 1-5-57 8th Position of the Firing of Volleys

i. Serial 9

On the command—

RELOAD (AS PER SERIALS 1–6)

- Bring the rifle down to the load position.
- At the same time move the left hand back to the hand guard with the thumb running parallel with the barrel.
- See Figure [1-5-58](#).



Figure 1-5-58 9th Position of the Firing of Volleys

j. Serial 10.

On the command—

PRESENT (AS PER SERIAL 7)

k. Serial 11.

On the command—

FIRE (AS PER SERIAL 8)

l. Serial 12.

On the command—

RELOAD (AS PER SERIAL 9)

m. Serial 13.

On the command—

PRESENT (AS PER SERIAL 7)

n. Serial 14.

On the command—

FIRE (AS PER SERIAL 8)

o. Serial 15.

On the command—

STOP

- Remove the forefinger from the trigger and place outside the trigger guard.
- At the same time bring the rifle down to the load position and transfer the left hand to the hand guard.
- See Figure [1-5-59](#).

Common faults—

- Leaving the finger on the trigger.
- Placing the left hand too close to the magazine housing.



Figure 1-5-59 10th Position of the Firing of Volleys

p. Serial 16

On the command—

SHOULDER – ARMS

- Bring the left foot back in line with the right.
- At the same time, force the rifle back into the shoulder.
- See Figure [1-5-60](#).



Figure 1-5-60 11th Position of the Firing of Volleys

q. Serial 17

On the command—

SQUAD... TWO

- The left arm is cut away and the rifle butt pulled back.
- See Figure [1-5-61](#).



Figure 1-5-61 12th Position of the Firing of Volleys

Note: Any malfunction must be disregarded during the procedure and is to be corrected later; the individual however must still go through the actions as taught. For instruction without blank cartridges the magazine spring can be removed before teaching this drill. This allows the working parts to go forward during the loading and unloading drills. Blank cartridges are to be retrieved where possible.

Chapter 6 – Sword Drill

1.6.1 General

- a. All sword drill are to be conducted wearing white gloves.
- b. Each sword drill movement is to be initially carried out by numbers. When proficiency has been developed personnel are to practice the movements, judging the time. A pause equal to two paces in quick time is observed between the movements unless otherwise stated. Sword drills are to be carried out smoothly and without unnecessary movement or jerking of the sword or of the arms.
- c. When marching in quick time with the sword in the scabbard—
 - (1) the scabbard is steadied, in line with the seam of the trousers, with the left hand at its full extent;
 - (2) forefinger down the side of the scabbard;
 - (3) thumb around the scabbard from the front; and
 - (4) remaining fingers around the back.
- d. When marching in quick or slow time with sword drawn, the scabbard is held steady at the side in line with the seam of the trousers.
- e. When the sword is carried in the scabbard, personnel salute with their right hand.
- f. When halted with the sword at the carry personnel salute with the sword.
- g. Parade commanders are to accord royalty or other dignitaries and reviewing officers a full salute. When not on parade the brief salute is to be used. Officers on a parade in receipt of individual commands or others, such as those involved in dismissal instructions, are to acknowledge the royalty, other dignitaries and reviewing officers by the use of the brief salute.
- h. Swords are worn by Service officers on the following occasions—
 - (1) His Majesty's Levees.
 - (2) State and other ceremonial occasions, when ordered.
 - (3) When on guard duty at royal residences.
 - (4) When escorting royalty.
 - (5) When on guards of honour.
- i. When paying ceremonial visits to, or receiving ceremonial visits from, governors general, diplomatic officers of and above the rank of charge d'affaires, foreign officers and foreign officials.
- j. Such other occasions as may be ordered by Air Staff or the Heritage, Commemoration and Protocol Group (HCP).

UNCLASSIFIED

NZAP 2.4 Manual of Ceremonial and Drill
Part 1 – Foot and Weapons Drill
Chapter 6 – Sword Drill

Version 6.00
13 June 2023

1.6.2 Warrant officers

- a. Warrant officers (W/Os) are to be instructed in sword drill in the same manner and style as commissioned officers.
- b. Swords are worn by W/Os for ceremonial parades.
- c. Non-commissioned officers (NCOs) filling officer or W/O appointments are not to carry swords. They are to be armed with the MARS-L rifle.
- d. When worn by a W/O, the sword is not to be drawn except under the following circumstances—
 - (1) When the W/O is a member of the Queens Colour party (QCP) or a Squadron Standard party (SqSP).
 - (2) When acting in the capacity of a commissioned officer during a ceremonial parade.

1.6.3 Method of wearing the sword

Officers on guards of honour, a parade commander (PCDR) and officers under their orders, are to wear swords in the following style—

- (1) Air Commodore (AIR CDRE) and above wear a sword on the inside of the jacket.
- (2) Officers of non-Air rank only wear a sword on the inside of the jacket on the following occasions—
 - (a) Dress as ordered.
 - (b) As a reviewing officer.
 - (c) At a Service wedding.
- (3) W/Os are to wear swords on the outside of the jacket.
- (4) The scabbard containing the sword is to hang on the slings.
- (5) The scabbard is to be raised, guard to the front, rings to the rear and the upper ring passed over the hook on the belt.
- (6) The shorter (front) sling is looped forward between the body and the scabbard.

1.6.4 Sword care and maintenance

- a. White gloves are to be worn when cleaning swords.
- b. No form of abrasive is permitted in cleaning swords. The gilt parts should be washed in warm soapy water and then polished with a soft dry cloth. The leather parts may be polished with liquid boot polish.

- c. After use in inclement weather, the blade is to be wiped dry before returning it to its scabbard. When not in use, the blade should be lightly covered in grease to prevent corrosion.
- d. If practice swords are available, they should be used in preference to ceremonial swords for all rehearsals.

1.6.5 Positions of attention and standing at ease/easy and draw/return swords

- a. There is a formal method of drawing the sword and the significance of ‘kissing the cross’, which signifies allegiance to the crown on the draw swords. The movements with the sword are all in time with rifle drill where appropriate and as a consequence, drills are performed smartly. Revise the correct method of carrying the sword.
- b. Position of attention
 - (1) The normal position of attention is adopted (refer to Figure [1-6-1](#) and Figure [1-6-2](#)).
 - (2) The sword is carried in the scabbard, hooked to the belt with the guard to the front.
 - (3) The scabbard is held in a perpendicular position between the thumb and forefinger of the left hand—
 - back of the hand outward;
 - forefinger extended down the scabbard;
 - remaining fingers curled behind and enveloping the scabbard; and
 - thumb to the right and on the inside of the scabbard.



Figure 1-6-1 The Position of Attention While Wearing a Sword

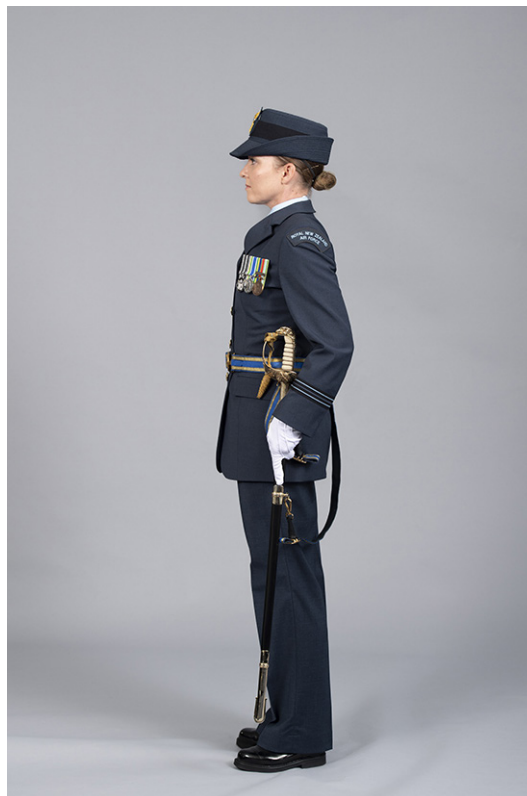

Figure 1-6-2 The Position of Attention While Wearing a Sword

- c. Standing at ease.
- The left foot is placed 30 cm to the left.
 - The arms remain in the position of attention.
 - See Figure [1-6-3](#).



Figure 1-6-3 The Position of Stand at Ease While Wearing a Sword

- d. Draw swords. The draw swords is carried out in three movements.

On the command—

DRAW SWORDS

BY NUMBERS – ONE

- The right hand is carried smartly across the body.
- The sword grip is seized by the right hand.
- See Figure [1-6-4](#).



Figure 1-6-4 1st Position of the Draw Swords

BY NUMBERS - TWO

- The sword is drawn smoothly and slowly from the scabbard, edge to the front, to a count equal to five paces in slow time.
- As soon as it is clear, the blade is turned over to a perpendicular position, edge to the left, the thumb to the rear and in line with the mouth.
- While being drawn, the right elbow is kept close to the body and is to remain close to the body when the sword is clear.
- See Figure [1-6-5](#).

This position is known as the recover.



Figure 1-6-5 2nd Position of the Draw Swords - The Recover

BY NUMBERS – THREE

- After a pause equal to two beats in quick time the sword is brought smartly down in front of the shoulder, blade perpendicular and the edge to the front, so that the right forearm is horizontal.
- The elbow is held close to the body.
- The wrist is straight.
- The hilt rests on the top of the hand.
- See Figure [1-6-6](#).

This position is known as the carry.

Note: The sword should not be gripped in the palm of the hand. It should rest lightly on the top of the hand between thumb and forefinger. Any corrections for wind etc should be made by applying pressure with the fingers under the hilt.



Figure 1-6-6 3rd Position of the Draw Swords – The Carry

e. Standing at ease with a drawn sword—

- (1) The left foot is placed 30 cm to the left.
- (2) The arms remain in the position of attention.
- (3) On the command—

STAND AT – EASE

- The left knee is bent.
- The left foot is driven sideways as normal.
- At the same time the grip of the sword is relaxed to allow the blade to fall back lightly on the right shoulder centrally between the neck and the point of the shoulder.
- The wrist may be bent back slightly to accommodate the movement but the right forearm remains parallel to the ground.
- See Figure [1-6-7](#).



Figure 1-6-7 The Position of Stand at Ease with Sword Drawn

f. Standing easy.

(1) On the Command—

STAND EASY

- The sword tip is lowered to the front and placed on the inside welt of the left shoe to a point approximately in line with the joint of the big toe.
- The left hand is brought across in front of the body so that both hands rest on top of the guard, right over left.
- The outside face of the guard is to face the right.
- See Figure [1-6-8](#).



Figure 1-6-8 The Position of Standing Easy with Sword Drawn

- (2) When a precautionary command is given—
- the left hand resumes its place on the scabbard; and
 - the is blade returned to rest on the shoulder in the correct position of at ease.
 - See Figure [1-6-9](#).



Figure 1-6-9 The Position of Standing at Ease with Sword Drawn

g. **Return sword.** The return sword is carried out in three movements.

(1) On the command—

RETURN SWORDS

BY NUMBERS – ONE

- The hilt of the sword is placed in the hollow of the left shoulder, blade perpendicular, edge to the left, with the forearm and elbow held close to the chest.
- At the same time the scabbard is gripped at the mouth with the left hand, back of the hand to the left.
- The mouth of the scabbard is brought forward.
- See Figure [1-6-10](#).



Figure 1-6-10 1st Position of the Return Swords

BY NUMBERS – TWO

- The right hand is raised and the point of the sword turned downwards with the edge to the front.
- The head is lowered and the eyes directed to the mouth of the scabbard.
- The sword is lowered smoothly and slowly, to a count equal to five paces in slow time, into the scabbard.
- See Figure [1-6-11](#).



Figure 1-6-11 2nd Position of the Return Swords

BY NUMBERS – THREE

- After a pause equal to two beats in quick time both hands are brought smartly to the sides and the position of attention resumed.
- See Figure [1-6-12](#).



Figure 1-6-12 3rd Position of the Return Swords

1.6.6 Saluting with the sword at the halt

- a. The full salute from the carry when halted is carried out in two movements.

On the command—

TO THE FRONT SALUTE

BY NUMBERS – ONE

- The sword is brought to the recover. In this movement it is necessary to change the position of the hand on the grip so that the thumb nail faces the mouth.
- This is achieved by a flick of the wrist as the hand moves towards the mouth so that the handgrip (and sword) rotates in the hand and then, the hand re-grips the sword so that the guard faces the left and the thumb sits 'on the snake skin' grip, thumb nail facing the mouth.
- This eliminates the cocked wrist mentioned below.
- With the hand in this position on the grip, the next movement can be made without the right wrist being cocked out to the side.
- See Figure [1-6-13](#).

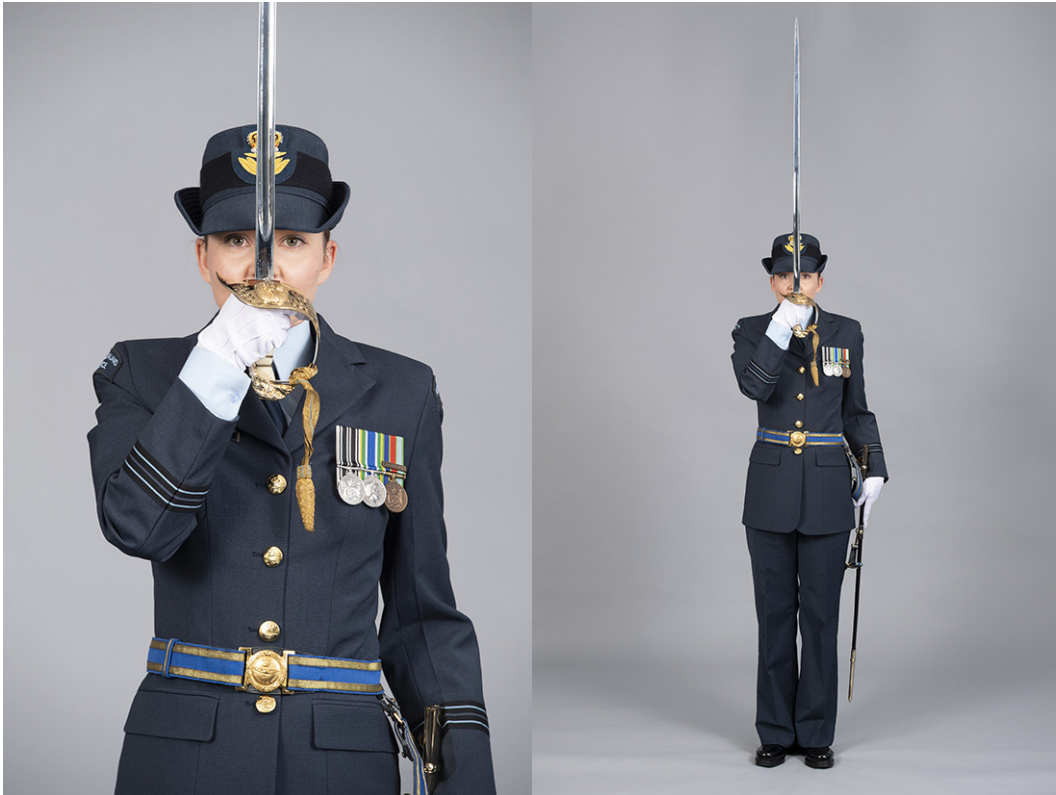

Figure 1-6-13 The Salute Position

BY NUMBERS - TWO

- The sword is brought down smoothly to make an angle of 45° with the ground, pointing straight forward without touching the ground, the edge to the left.
- The right arm and wrist are straight, with the thumb nail facing upwards.
- The elbow is held close to the body.
- The hilt rests against the back of the thigh.
- See Figure [1-6-14](#).



Figure 1-6-14 The Salute with the Sword Position at the Halt

- b. When officers are parading with ORs carrying weapons.
- (1) On the command—
PRESENT – ARMS
 - The sword is brought to the recover on the first movement of the rifle.
 - The sword is brought to the salute on the second movement of the rifle.
 - The right wrist is not cocked outwards to the right.
 - (2) On the command—
SHOULDER – ARMS
 - The sword is brought to the recover on the first movement of the rifle.
 - The sword is brought to the carry on the second movement of the rifle.

1.6.7 The brief salute

- a. The brief salute is carried out in two movements.

On the command—

TO THE FRONT – SALUTE

- The sword is brought to the recover as for the first movement at paragraph [1.6.5d](#).

- The sword remains in position for a period equal to two paces in quick time before the carry is resumed.
- See Figure [1-6-15](#).



Figure 1-6-15 The Brief Salute

1.6.8 Saluting from the carry when marching past

- a. The requirement to salute when marching past and as part of an armed parade. Carrying the sword slung is not common for all officers and is more commonly for escorting or reviewing officers.
- b. When a unit is marching past on a ceremonial parade—
 - (1) Officers start the salute on the command—
EYES – RIGHT/LEFT
 - (2) Officers complete it on the command—
EYES – FRONT
 - All movements are carried out as the left foot moves forward.
 - The salute to the right/left is carried out in two movements.
 - (3) On the command—
EYES – RIGHT/LEFT
BY NUMBERS – ONE

- After a check pace with the right foot, the sword is brought to the recover.
- At the same time the head is turned in the direction ordered.
- See Figure [1-6-16](#).



Figure 1-6-16 1st Position of Saluting on the March

BY NUMBERS – TWO

- The sword is lowered to the front (as when saluting to the front).
- When saluting to the right/left on the march, judging the time, movements one and two are performed as the left foot touches the ground, on successive left foot steps.
- See Figure [1-6-17](#).



Figure 1-6-17 2nd Position of Saluting on the March

1.6.9 The carry from the salute

The carry from the salute is carried out in two movements.

(1) On the command—

EYES – FRONT

BY NUMBERS – ONE

- After a check pace with the right foot, the sword is brought to the recover.
- The sword is carried well to the front.
- At the same time the head is turned to the front.
- See Figure [1-6-18](#).



Figure 1-6-18 1st Position of the Carry from the Salute

- (2) On the command—
BY NUMBERS – TWO
– The sword is brought to the carry.
- (3) These movements are carried out as the left foot touches the ground on successive steps.
- (4) See Figure [1-6-19](#).



Figure 1-6-19 2nd Position of the Carry from the Salute

1.6.10 Dismissing with the sword

The following procedure on an armed parade is to be adopted when dismissing officers.

On the command—

FALL OUT THE OFFICERS

- Officers move out at the carry and form up as for normal squadron drill dismissal in front of the PCDR.
- The officer on the right (normally No. 1 Flight commander (FLTCDR)) is to take one pace forward to give the signal for the salute, in this case the brief salute. Remaining officers will take their cue from this salute.
- The officers will then act on the commands of No. 1 FLTCDR for march off and dismissal.
- The PCDR will, having called for the squadron warrant officer (SWO), acknowledge them with a brief salute.
- The PCDR and SADJ will march off and return swords together at a predetermined point.
- At a predetermined point the FLTCDRs will on command from No. 1 FLTCDR, return swords together. This can be done informally.

1.6.11 The slung position

a. Position of attention.

- The sword, in its scabbard, is held perpendicularly at the left side, with—
 - the guard to the front; and
 - the shoe of the scabbard resting on the ground just in front of the heel of the foot.
- The grip is grasped with the fingers and thumb—
 - the back of the hand to the left; and
 - the elbow close to the side.
- See Figure [1-6-20](#).

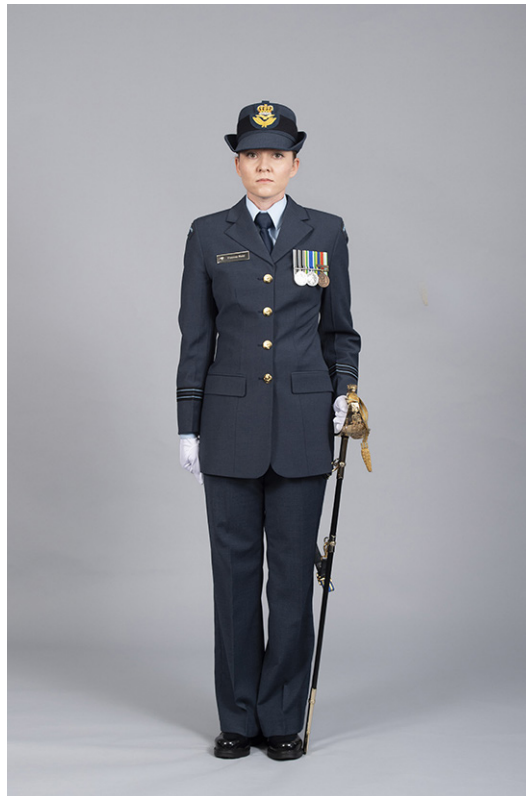

Figure 1-6-20 Position of Attention in the Slung Position

b. Stand at ease.

- The left foot is moved 30 cm to the left.
- The scabbard is carried off with the left foot and rested as in the position of attention.
- At the same time the guard is carried forward to the full extent of the left arm.
- See Figure [1-6-21](#).



Figure 1-6-21 Position of Ease in the Slung Position

c. Quick march

- On the first pace, the hilt of the sword is canted smartly upward and to the rear with the left hand, without stooping or disturbing the position of the body.
- The scabbard is—
 - gripped at the point of balance;
 - held at an angle of 45° with the ground;
 - held with thumb and fingers around the scabbard;
 - held with arm fully extended, close to the side; and
 - rings of the scabbard downwards.
- See Figure [1-6-22](#).

Note: When it is necessary to move only a few paces, the sword is raised vertically about 75 mm from the ground on stepping off and lowered to the position of attention when halting.



Figure 1-6-22 Position Ready to Quick March in the Slung Position

d. Halt

- The sword is lowered to the ground.
- The position of attention is resumed.
- See Figure [1-6-23](#).



Figure 1-6-23 Position of Attention in the Halt Position

1.6.12 Wearing the sword at levees

- a. At levees the sword is worn in the slung position.
- b. **Entering the Throne Room.** When entering the Throne Room the sword is carried as instructed in the note to paragraph [1.6.11c](#).

PART 2 – FORMATION DRILL

Contents

| | |
|--|-------------|
| Chapter 1 – Drill | 2-1 |
| 2.1.1 Object of drill | 2-1 |
| 2.1.2 Directing flank | 2-1 |
| 2.1.3 Variation of time | 2-1 |
| 2.1.4 Moving with weapons | 2-1 |
| Table 2-1-1 Procedure for Sizing a Flight..... | 2-2 |
| 2.1.5 Sizing a flight..... | 2-2 |
| 2.1.6 Movements of a flight in line | 2-3 |
| Chapter 2 – Flight Drill | 2-12 |
| 2.2.1 Object of flight drill | 2-12 |
| 2.2.2 Correcting a dressing..... | 2-12 |
| Table 2-2-1 Personnel Positions in Various Formations..... | 2-12 |
| 2.2.3 Changing ranks..... | 2-13 |
| 2.2.4 Moving backward..... | 2-13 |
| 2.2.5 Parading a flight | 2-13 |
| 2.2.6 Roll call | 2-14 |
| 2.2.7 Handing over | 2-14 |
| 2.2.8 Inspection of a flight | 2-15 |
| 2.2.9 Dismissing a flight | 2-15 |
| Figure 2-2-1 Flight Formations..... | 2-17 |
| Chapter 3 – Squadron Drill | 2-18 |
| 2.3.1 Object of squadron drill..... | 2-18 |
| Table 2-3-1 Squadron Formations | 2-18 |
| 2.3.2 Dressing | 2-18 |
| Table 2-3-2 Personnel Positions in Various Formations..... | 2-19 |
| 2.3.3 Turning about or retiring | 2-20 |

| | |
|---|-------------|
| Chapter 4 – Squadron Parade Procedure | 2-21 |
| 2.4.1 Preliminary | 2-21 |
| 2.4.2 Parade formation | 2-21 |
| Table 2-4-1 Squadron Parade Form Up Procedure | 2-21 |
| Table 2-4-1 Squadron Parade Form Up Procedure (cont.) | 2-22 |
| Table 2-4-2 Markers Close Column Distance | 2-24 |
| 2.4.3 Parade inspection | 2-25 |
| Table 2-4-3 Procedure for Squadron Parade Inspection by Squadron Commander | 2-25 |
| Table 2-4-4 Alternative Procedure for Squadron Parade Inspection by Squadron Commander | 2-26 |
| 2.4.4 Dismissing a squadron | 2-26 |
| Table 2-4-5 Procedure for Dismissing a Squadron Parade | 2-27 |
| 2.4.5 Movements in column of threes | 2-28 |
| Table 2-4-6 Movements in Column of Threes | 2-28 |
| 2.4.6 Movements of a squadron in close column of flights | 2-30 |
| Table 2-4-7 Movements of a Squadron in Close Column of Flights | 2-30 |
| 2.4.7 Movements of a Squadron in Column of Flights | 2-32 |
| Table 2-4-8 Movements of a Squadron in Column of Flights | 2-32 |
| Figure 2-4-1 Squadron in Close Column of Flights | 2-35 |
| Figure 2-4-2 Squadron in Line | 2-36 |
| Figure 2-4-3 Squadrons in Column of Route and Column of Threes | 2-37 |
| Chapter 5 – Wing Drill | 2-38 |
| 2.5.1 Object of wing drill | 2-38 |
| 2.5.2 Formations | 2-38 |
| 2.5.3 Dressing | 2-38 |
| Table 2-5-1 Wing Formations | 2-39 |
| 2.5.4 Responsibility for words of command | 2-39 |
| 2.5.5 Change of formation | 2-39 |
| Table 2-5-2 Officer and Supernumerary NCO Positions | 2-40 |

| | | |
|------------------|--|-------------|
| 2.5.6 | Movements of a wing from column of route/threes to column of squadrons | 2-40 |
| 2.5.7 | Procedure for wing fall-in | 2-40 |
| 2.5.8 | Full procedure | 2-40 |
| 2.5.9 | Alternative procedure for wing fall-in | 2-46 |
| 2.5.10 | Inspection by the wing commander | 2-47 |
| 2.5.11 | Dismissing a wing | 2-49 |
| 2.5.12 | Wing drill movements. | 2-49 |
| | Figure 2-5-1 Wing in Close Column of Squadrons | 2-51 |
| | Figure 2-5-2 Wing in Line of Squadrons in Close Column of Flights | 2-52 |
| | Figure 2-5-3 Wing in Column of Route | 2-53 |
| Chapter 6 | – Marching Discipline | 2-54 |
| 2.6.1 | Object of march discipline. | 2-54 |
| 2.6.2 | Marching in column of route | 2-54 |
| 2.6.3 | Distances. | 2-54 |
| 2.6.4 | Signals. | 2-55 |
| 2.6.5 | Rules of marching | 2-55 |

Chapter 1 – Drill

2.1.1 Object of drill

The object of rehearsing a flight in drill routines is to ensure that when personnel are required to take their place in a flight, they are capable both individually and as a unit, to carrying out any movements or formations as may be required by the flight commander (FLTCDR).

2.1.2 Directing flank

- a. When a flight moves off, the directing flank is indicated by the command—
BY THE RIGHT/LEFT
QUICK – MARCH
- b. When a flight is moving diagonally in line, the directing flank is that towards which the flight is inclining.
- c. When a flight is marching in a line by a flank and it is intended to change the direction to the opposite flank, the new flank of direction is indicated before the actual command to change direction is given.

On the command—

BY THE RIGHT/LEFT

- The directing flank is that on which the change of direction is to be made and the forward movement on the completion of the change is directed by that flank unless otherwise ordered.
- d. When a flight or unit is marching on a road, the left flank is normally to direct.
 - e. When a flight is moving diagonally in sections of threes, the directing flank is that towards which the flight is inclined.
 - f. When a flight that is in sections of threes is required to wheel, the pivot flank is the directing flank during the wheeling movement. The flight marches by the original flank of direction on completion of the wheel.

2.1.3 Variation of time

This section of the manual deals with the movements of a flight in quick time; therefore when a movement is to be carried out in slow or double time, the word 'SLOW' or 'DOUBLE' is substituted for the word 'QUICK'.

2.1.4 Moving with weapons

When carrying rifles, all movements are done at the position of attention.

Table 2-1-1 Procedure for Sizing a Flight

| Serial | Commander | Command | Action |
|--------|-----------|--|--|
| 1 | CDR | TALLEST ON THE RIGHT SHORTEST ON THE LEFT IN SINGLE RANK SIZE | <ul style="list-style-type: none"> – ORs, with the exception of the marker— – turn to the left; – break ranks; – form a single rank according to size on the left of the marker; and – dress without intervals. |
| 2 | CDR | FLIGHT NUMBER | <ul style="list-style-type: none"> – ORs are to number from right to left. |
| 3 | CDR | ODD NUMBERS TWO PACES FORWARD MARCH | <ul style="list-style-type: none"> – The even numbers stand fast. – The odd numbers take two paces forward. |
| 4 | CDR | No.1 STAND FAST RANKS RIGHT AND LEFT – TURN | <ul style="list-style-type: none"> – The odd numbers, with the exception of No.1, turn to the right. – The even numbers turn to the left. |
| 5 | CDR | FORM FLIGHT QUICK – MARCH | <ul style="list-style-type: none"> – ORs, with the exception of No.1 step off. – The even numbers wheel to the right and follow the last person of the odd numbers. – No.3 OR halts one pace behind No.1 aviator; – No.5 OR halts one pace behind No.3 aviator; – No. 7 OR halts to the left of No.1 aviator; – No.9 OR halts one pace behind No.7 aviator, and so on. – ORs, on reaching their respective places, turn to their left and take up dressing by the right |

2.1.5 Sizing a flight

- a. When sizing a flight, the tallest person of the flight is placed in the front of the right hand person as a marker.
- b. The procedure for sizing a flight is shown in Table [2-1-1](#). When the dimensions of the ground do not permit the sizing in single rank, other ranks (ORs) are sized in three ranks at open order. The same procedure is carried out by each rank, with the exception that, on the command—

**FORM FLIGHT
 QUICK – MARCH**

- ORs of the odd numbered ranks—
- turn to the front; and
- take up their dressing by the right.

- ORs of the even numbered ranks—
 - march forward a set number of paces according to the size of the flight;
 - wheel to the right;
 - form up on the left of the odd numbers; and
 - take up their dressing by the right.

2.1.6 Movements of a flight in line

a. Moving to the front

On the command—

BY THE RIGHT/LEFT

QUICK – MARCH

- The flight is to step off.
 - The front person of the file on the flank which had been named is to select points ahead of them so as to maintain direction.
 - ORs of each rank, with the exception of the directing file, are to glance occasionally to the named flank (without turning the head) in order to maintain their dressing.
 - ORs of the centre and rear ranks are to maintain their covering and distance from the rank in front.
 - A blank file consisting of one person is to be with the leading rank at all times.
- (1) When a flight is turned about on the march, the person is to mark time for two paces on the command 'ABOUT' and thus gain their position on the new leading flank before the turn is completed.
 - (2) When the flight is turned about at the halt, they are to take two paces forward after turning about.

b. Moving to the rear

- (1) When a flight is required to move to the rear for a short distance before resuming the original direction, the following commands are to be given—

FLIGHT WILL RETIRE

ABOUT – TURN

- the flight turns about; and
- marches the required distance.

- (2) When the required short distance has been covered, the command is given—

FLIGHT WILL ADVANCE

ABOUT – TURN

- The flight turns about to face the original direction.
- The ranks are not changed.

c. Right/left incline

(1) On the command—

FLIGHT

RIGHT/LEFT IN – CLINE

- The flight turns in the direction ordered.
- The right/left hand OR of the front rank select points ahead in order to maintain direction.
- The personnel of each rank, with the exception of the directing file, maintain their dressing by the right flank.
- The personnel of the centre and rear ranks maintain positions relative to the personnel in the rank in front, so that they cover correctly when they are again turned into line.

(2) When a flight is required to move in the original direction, the following command is given—

FLIGHT

RIGHT/LEFT IN – CLINE

d. Forming two ranks from three

To form two ranks from three, the movements required are—

- The odd numbers of the centre rank—
 - take a pace to the left with the left foot;
 - take a pace forward with the right foot; and
 - bring the left foot in to the right foot.
- At the same time the even numbers of the centre rank—
 - take a pace to the left with the left foot;
 - take a pace to the rear with the right foot; and
 - bring the left foot in to the right.

e. Forming three ranks from two

(1) On the command—

FLIGHT,

FORM TWO – RANKS

- The odd numbers of the original centre ranks—
 - take a pace to the rear with the left foot;
 - take a pace to the right with the right foot; and
 - bring the left foot in to the right foot.
- At the same time the even numbers of the original centre rank—
 - take a pace forward with the left foot;

- take a pace to the right with the right foot; and
 - bring the left foot in to the right foot.
- (2) When a flight is in the retire position (ie with the rear rank in the front), the movements detailed in this paragraph are reversed.
- (3) On completion of the movement the following command is given—
- FLIGHT**
RIGHT/LEFT – DRESS
- f. Movement of a flight in column of threes
- (1) When a flight is required to move from one point of assembly to another, they march in column of threes. When there is a blank file consisting of one OR, it is to be on the directing flank.
- (2) A test of good marching in threes is indicated by the position of the ORs when they are turned into line. There should be no gaps or irregularities in a line after turning, and the flight should occupy the same frontage as before it moved to a flank. This test is to be applied during the instruction of ORs and any carelessness in the maintenance of the exact distance and interval is to be checked and corrected immediately.
- g. Turning to a flank from line when halted
- On the command—
- MOVE TO THE RIGHT/LEFT IN THREES**
RIGHT/LEFT – TURN
- The flight turns in the direction indicated.
- h. Forming line from threes facing a flank when halted
- On the command—
- FLIGHT WILL ADVANCE**
LEFT/RIGHT – TURN
- The flight turns in the direction indicated.
- i. Turning to a flank from line when marching
- On the command—
- MOVE TO THE RIGHT/LEFT IN THREES**
RIGHT/LEFT – TURN
- the flight turns in the direction indicated.

UNCLASSIFIED

NZAP 2.4 Manual of Ceremonial and Drill
 Part 2 – Formation Drill
 Chapter 1 - Drill

Version 6.00
 13 June 2023

- j. Forming line from threes when marching
- On the command—
- FLIGHT WILL ADVANCE**
RIGHT/LEFT – TURN
- the flight turns in the direction indicated.
- k. Changing direction
- (1) On the command—
- CHANGE DIRECTION RIGHT/LEFT**
RIGHT/LEFT WHEEL
- The right/left hand OR of the leading sections of threes on the inside of the turn—
 - moves round on the arc of a circle (120 cm); and
 - steps six short paces of 30 cm to enable the other two ORs of the section to wheel with them.
 - The other ORs are to look inwards towards the right/left OR as they wheel, ie they are to look to the direction they are wheeling.
 - When the section has wheeled through a quarter of a circle, it leads on in the new direction and the ORs turn their heads to the front.
- (2) When a flight is ordered to halt or mark time and only part of it has wheeled in the new direction, the following command is given—
- REAR THREES COVER**
- The sections of threes that have not wheeled—
 - cover those sections that have wheeled; and
 - move to their places by the shortest route.
- (3) When a flight is required to wheel at an angle less than a complete right or left wheel the following command is given (when the leading section of threes is facing in the required direction)—
- FORWARD**
- the leading section of threes wheels to face the required direction.
- l. Forming two files and single file from three files, and vice versa
- (1) On the command—
- FORM TWO – FILES (MARCHING TO THE RIGHT)**
- The odd numbers of the centre ranks—
 - disengage to the left rear; and
 - take up their position behind their respective front rank OR.

- At the same time, the even numbers of the centre rank—
 - disengage to the right rear; and
 - take up their position behind their respective rear rank OR.
 - ORs are to adjust their correct distance in succession from front to rear.
- (2) On the command—
- FORM SINGLE – FILE (MARCHING TO THE RIGHT)**
- ORs of the file on the right take up their position behind the ORs on their left.
 - ORs adjust their correct distances in succession from front to rear without further orders.
- (3) On the command—
- FORM TWO – FILES**
- ORs of the original file take up their positions on the right of the ORs immediately in front of them.
 - During this movement the leading OR of the left file steps short.
 - The remainder correct their distance and dressing, and then step short.
- (4) When the flight is re-formed the FLTCDR gives the command—
- QUICK – MARCH**
- (5) On the command—
- FORM THREE – FILES**
- The odd numbers of the original centre ranks—
 - disengage to their right front; and
 - take up their positions abreast of their respective front and rear rank ORs.
 - At the same time the even numbers of the original centre ranks—
 - disengage to their left front; and
 - take up positions abreast of their respective front and rear rank ORs.
 - During this movement the leading OR of the rear and front ranks step short.
 - The remainder correct their distance and dressing, and then step short.
- (6) When the flight is re-formed, the FLTCDR gives the command—
- QUICK – MARCH**
- The movements detailed above are reversed when a flight is moving with the left flank leading.

- m. Dismissing without weapons
- (1) On the command—
DIS – MISS
 - ORs turn half right;
 - observe a pause equal to four paces in quick time; then
 - march off the parade ground in quick time.
 - (2) If an officer is present, a Warrant Officer (W/O) or Non Commissioned Officer (NCO), is to give the command—
OFFICER ON PARADE, DIS – MISS
 - officers turn half right;
 - observe a pause equal to two paces in quick time;
 - salute;
 - on completion of the salute, they observe a pause equal to four paces in quick time; then
 - leave the parade ground in quick time.
 - (3) Where an officer requires ORs under their command to be dismissed, they order a W/O or NCO to dismiss them. The officer returns the salute.
- n. Dismissing with weapons
- (1) ORs armed with rifles are dismissed with the rifles at the shoulder.
 - (2) On the command—
DIS – MISS
 - ORs turn half right;
 - observe a pause equal to four paces in quick time; then
 - march off the parade ground in quick time.
- o. Changing direction by forming – at the halt
- (1) On the command—
**CHANGE DIRECTION RIGHT/LEFT
 RIGHT/LEFT – FORM**
 - The right/left hand OR of the front rank makes a full turn in the required direction.
 - The remainder of the front rank make a right/left incline.
 - The centre and rear ranks stand fast.

- (2) On the command—

QUICK – MARCH

- The right/left hand OR of the front rank—
 - moves forward three paces; and
 - marks time.
- The remainder step off.
- The ORs of the centre and rear ranks conform to the movements of the front rank.
- The whole flight marks time when they come into their places in the new alignment.

- (3) On the command—

FOR – WARD

- The entire flight moves forward in the new direction.

- (4) If the command 'CHANGE DIRECTION RIGHT/LEFT, AT THE HALT, RIGHT/LEFT - FORM' is given—

- The movement is carried out as described in paragraphs [2.1.6o.\(1\)-\(3\)](#), except that on the command 'QUICK - MARCH' the right/left hand OR—
 - advances three paces; and
 - halts.
- The remainder halt as they come up in line with the right/left hand OR.

p. Changing direction by forming - on the move

- (1) On the command (given as for a right/left turn)—

CHANGE DIRECTION RIGHT/LEFT, RIGHT/LEFT – FORM

- The right/left hand OR of the front rank makes a full turn in the required direction.
- The remainder of the front rank a right/left incline.
- The right/left hand OR moves forward three paces and marks time.
- The remainder of the front rank, after inclining, form up on the left/right of the right/left hand OR and mark time.
- The centre and rear ranks conform to the movements of the front rank by—
 - observing the block pace without inclining; and
 - marking time when they come into their places in the new alignment.

- (2) On the command—

FOR – WARD

- The whole flight moves forward in the new direction.

- (3) If the command is 'CHANGE DIRECTION RIGHT/LEFT, AT THE HALT RIGHT/LEFT - FORM', the movement is carried out as described in paragraphs [2.1.6p.\(1\)-\(2\)](#), except that on arrival on the new alignment each OR halts.
- (4) The suggested sequence in which to teach forming is as follows—
- (a) From the Halt to the Halt.
 - (b) From the Halt to the Move.
 - (c) From the Move the Move.
 - (d) From the Move to the Halt.
- q. Forming flight on left/right at the halt
- (1) On the command—
ON THE RIGHT/LEFT FORM – FLIGHT
 - The right/left hand OR of the leading three stands fast.
 - The remainder of the flight makes a right/left incline.
 - (2) On the command—
QUICK – MARCH
 - The right/left hand OR of the leading three moves forward three paces and marks time.
 - The remainder step off and form up in line on the right/left of the right/left hand guide.
 - The centre and rear ranks conform to the movements of the front rank.
 - The whole flight marks time when they come into their places in the new alignment.
 - (3) On the command—
FOR – WARD
 - The entire flight moves forward in time in the new direction.
 - If the command is 'AT THE HALT ON THE RIGHT/LEFT, FORM - FLIGHT', the movement is carried out as prescribed in the paragraphs [2-1-6q.\(1\)-\(3\)](#) except that, on the command 'QUICK MARCH'—
 - the right/left hand OR advances three paces and halts; and
 - the remainder halt as they come up into their new alignment.
- r. Forming flight on left/right on the move
- (1) On the command (given as for a right/left turn)—
ON THE RIGHT/LEFT, FORM – FLIGHT
 - The right/left hand OR of the leading three will move forward three paces and mark time.

- The remainder of the flight will make a right/left incline and form up on the right/left of the right/left hand) OR.
 - The centre and rear ranks conforming to the movements of the front rank, and mark time when they come into their places in the new alignment.
- (2) On the command—
- FOR – WARD**
- The entire flight will move forward in line in the new direction.
- (3) If the command is 'AT THE HALT ON THE RIGHT/LEFT), FORM FLIGHT', the right/left hand OR of the leading three will move forward three paces, except that on arrival on the new alignment each person will halt.
- (4) The suggested sequence in which to teach forming flight is as follows—
- (a) From the Halt to the Halt.
 - (b) From the Halt to the Move.
 - (c) From the Move to the Move.
 - (d) From the Move to the Halt.

Chapter 2 – Flight Drill

2.2.1 Object of flight drill

- a. Objectives. The object of flight drill is to ensure that when a flight is required to take its place in a squadron it is capable of carrying out any movement or formation that may be required by a squadron commander (SCDR).
- b. Formations. When a flight is formed up, officers and non-commissioned officers (NCOs) have specific positions for various formations. These can be found in Table [2-2-1](#).

2.2.2 Correcting a dressing

- a. When a dressing needs to be corrected the following commands are given—

FLIGHT

RIGHT/LEFT – DRESS

- The right/left guides and markers are to adjust their own positions.
- Other ranks (ORs) in the flight are to take up their own dressing from the guide and marker.

- b. When the dressing has been completed, the FLTCDR is to give the command—

EYES – FRONT

Note: Weapons are brought to the position of attention before dressing the flight.

Table 2-2-1 Personnel Positions in Various Formations

| Formation | Personnel | Position |
|---------------------------------------|------------------------|--|
| Line | FLTCDR | Two paces in front of the centre of the flight. |
| | Supernumerary officers | Equally spaced three paces in rear of the rear rank. |
| | F/S | Two paces to the rear of the centre of the rear rank. |
| | Supernumerary NCOs | Equally spaced two paces to the rear of the rear rank. |
| Column of route | FLTCDR | Two paces in front of the centre of the flight. |
| | Supernumerary officers | In sections of threes one pace to the rear of the F/S and supernumerary NCOs. |
| | F/S | One pace to the rear of the flight. |
| | Supernumerary NCOs | One pace to the rear of the flight. |
| Column of threes | All officers and NCOs | In the same relative positions as for a flight in line. They are to dress by a section of threes. In files, the officers and NCOs are to occupy the same relative positions as for a flight in line. |
| When supernumerary W/Os are on parade | | |
| Line | Supernumerary W/Os | At equal distances in the same rank as supernumerary NCOs. |
| Column of route | Supernumerary W/Os | Completing the rear section of threes of supernumerary NCOs. |

2.2.3 Changing ranks

When ranks are changed, the following command is given—

FLIGHT

ABOUT – TURN

- Supernumeraries are to turn about with the flight, then turn to their left and gain their new positions by marching round the left flank in quick time.
- When a flight is exercising with other flights, the FLTCDR is to turn to their right and move round by that flank in quick time.
- When a single flight is exercising, the FLTCDR is to take up position from which they can supervise to the best advantage.
- CPLs who are not required as guides and markers are to be in the ranks.

2.2.4 Moving backward

- a. When a flight is required to move back for a short distance, so as to resume its original front, the following precautionary command is given—

FLIGHT WILL RETIRE

- b. When the flight is again required to turn about, the precautionary command is given—

FLIGHT WILL ADVANCE

- In both instances, the supernumeraries are to retain their positions.

2.2.5 Parading a flight

The flight should be formed up adjacent to the parade ground.

- (1) On the command—

FLIGHT

- The flight is to brace up and adopt the correct stand-at-ease position.

- (2) On the command—

MARKER

- The marker is to come to attention.
- March out in quick time.
- Halt facing the flight sergeant (F/S) at a distance of three paces from them, and stand at ease.

- (3) The F/S is then to take up their position in a place where they can best supervise the falling in of the flight and then give the command—

ON PARADE

- On this command all ORs including the marker are to come to attention.
- The marker stands fast and the remainder of the flight march out in quick time and form up on the left of the marker.

UNCLASSIFIED

NZAP 2.4 Manual of Ceremonial and Drill
 Part 2 – Formation Drill
 Chapter 2 – Flight Drill

Version 6.00
 13 June 2023

- They are to automatically take up their dressing from the right.
- (4) When the F/S is satisfied that the dressing is correct they are to give the command—

EYES – FRONT**STAND AT – EASE**

- The F/S is now to take up position two paces in front centre of the flight.

2.2.6 Roll call

- a. The roll is now called.
- b. When an ORs name is called, they are to
 - (1) come to attention;
 - (2) answer the commander by their rank (F/S, sergeant (SGT) etc); and
 - (3) stand at ease after the name of the next OR is called.
- c. The last name called should be so indicated by the F/S, and that person should stand at ease having responded.

2.2.7 Handing over

- a. While the flight is being paraded and the roll called, supernumerary officers are to form up in line facing the front of the flight at a distance of 20 paces and stand at ease. The FLTCDR takes up position three paces to the rear of the F/S.
- b. The F/S, after calling the flight to attention, turns about, salutes the FLTCDR and reports the state of the flight. They are then to salute again, turn about and march to their position in rear of the flight.
- c. The FLTCDR gives the command—

FALL IN – THE OFFICERS

 - The officers—
 - come to attention;
 - turn to the right;
 - march out to their respective positions in the rear of the flight;
 - halt facing the right flank; and
 - turn to the front together.

2.2.8 Inspection of a flight

a. If the FLTCDR intends to carry out an inspection, the following procedures is to apply.

(1) No Inspection of Arms

(a) The FLTCDR gives the commands—

IN OPEN ORDER

RIGHT – DRESS

EYES – FRONT

– The FLTCDR carries out the inspection of the flight, accompanied by the F/S one pace to their right and one pace to the front.

(b) After the inspection the FLTCDR gives the commands—

IN CLOSE ORDER

RIGHT – DRESS

EYES – FRONT

(2) Inspection of Arms.

(a) The FLTCDR gives the commands—

IN OPEN ORDER

RIGHT – DRESS

EYES – FRONT

FOR INSPECTION

PORT – ARMS

(b) If the FLTCDR wishes to examine the barrels of the rifles, they give the command—

EXAMINE – ARMS

(c) On the completion of the inspection, the FLTCDR gives the commands—

SHOULDER ARMS

IN CLOSE ORDER

RIGHT – DRESS

EYES – FRONT

2.2.9 Dismissing a flight

a. When a flight is to be dismissed—

(1) The FLTCDR gives the commands—

FLIGHT

FLIGHT – SHUN

FALL OUT THE OFFICERS

UNCLASSIFIED

NZAP 2.4 Manual of Ceremonial and Drill
Part 2 – Formation Drill
Chapter 2 – Flight Drill

Version 6.00
13 June 2023

- The FLTCDR calls for the F/S and gives them the necessary orders to dismiss the flight.
 - The supernumerary officers—
 - turn to their left;
 - march out in quick time; and
 - halt in a semi-circle facing the FLTCDR at a distance of five paces.
 - The officer on the right takes one pace forward
 - All of the supernumerary officers—
 - take their time from the officer on the right; and
 - salute together.
- (2) After the salute, the officer on the right—
 - takes a pace back and gives the commands—

OFFICERS**RIGHT – TURN AND QUICK MARCH**

- The officers on the right leads the officers off the parade ground and dismisses them.

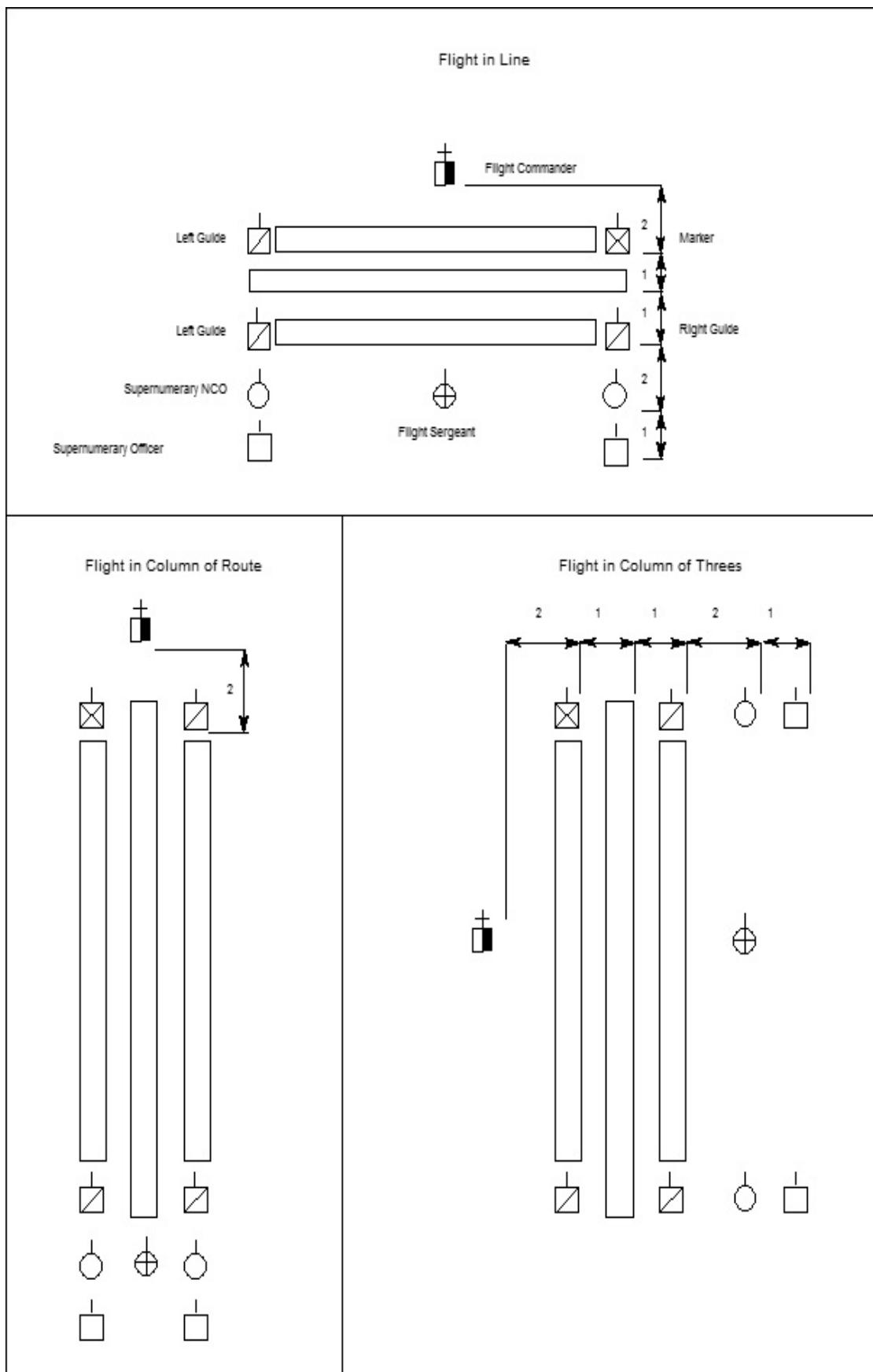

Figure 2-2-1 Flight Formations

Chapter 3 – Squadron Drill

2.3.1 Object of squadron drill

- a. The object of squadron drill is to train flights to act together as parts of a squadron and to exercise the squadron in movements that may be required in wing drill.
- b. **Formations.** The squadron may be formed up as detailed in Table [2-3-1](#).
 - (1) Unless otherwise ordered, the squadron is formed up in close column of flights and dresses by the right flank.
 - (2) When a squadron is formed up, the position of officers, warrant officers (W/Os) and non-commissioned officers (NCOs) is detailed in Table [2-3-2](#).

Table 2-3-1 Squadron Formations

| Formation | Description |
|-------------------------|--|
| Close column of flights | Flights on parallel and successive lines at 14 paces distance. |
| Column of flights | Flights on parallel and successive lines at a distance from one another equal to their own frontage and six paces. |
| Line | Flights on one alignment at six paces interval. |
| Column of route | Flights in column of route or threes at six paces distance between flights. |

- c. When a single squadron is exercising, the parade commander (PCDR) take up a position from which they can supervise to the best advantage.
- d. If a change of front is required, the guides and markers are not to change their positions; the guides are to act as markers and vice versa.
- e. W/Os and NCOs who are acting as flight commanders (FLTCDRs) are to take up their positions as laid down for FLTCDRs.

2.3.2 Dressing

If it is necessary to correct a dressing, the PCDR is to give the command—

SQUADRON
RIGHT/LEFT – DRESS
EYES – FRONT

- (1) On the command—
RIGHT/LEFT – DRESS
 – FLTCDRs and the SADJ turn about.
- (2) On the command—
EYES – FRONT
 – FLTCDRs and the SADJ turn to the front.

Table 2-3-2 Personnel Positions in Various Formations

| Formation | Personnel | Position |
|-------------------------|---|---|
| Close column of flights | PCDR | Six paces in front of the centre of the leading flight. |
| | SADJ | Two paces in front of the right file of the leading flight. |
| | SWO | Two paces in rear of the right file of the leading flight. |
| | The remaining officers and NCOs are to be in positions laid down for a flight in line. In any change of direction or position, the SWO is to retain their position relative to the right file of the leading flight. They are to supervise the direction, covering and distances of the right guides and markers when the squadron is marching. | |
| Column of flights | In column of flights the positions are as laid down for close column of flights. | |
| Line | PCDR | Six paces in front of the centre of the squadron. |
| | SADJ | Two paces in rear and one pace to the left of the PCDR. |
| | SWO | Two paces in rear of the right file of the flight on the right. |
| | The remaining officers and NCOs are to be in the same relative positions as laid down for a flight in line. | |
| Column of route | SCDR | Six paces centrally in front of the leading guide and marker. |
| | SADJ | Two paces in rear and one pace to the left of the squadron commander. |
| | The remaining officers and NCOs are to be in the same relative positions as for a flight in column of route. | |
| Column of threes | Officers, W/O's and NCO's are to be in the same relative positions as laid down for a squadron in close column of flights or a flight in line. | |

- (3) The dressing is carried out as follows—
- (a) Close column of flights and column of flights, each flight is to dress on the guide and marker on the flank of direction.
 - (b) In line, the squadron is to dress on the guide and marker of the flight on the flank of direction in the same manner as for a flight in line.
- (4) The PCDR is then to give the command—
- EYES – FRONT**
- When the squadron is marching, the guide and marker on the directing flank are responsible for maintaining the direction.

- The guides and markers at the rear are responsible for the covering and correct distance of their flights.

2.3.3 Turning about or retiring

- a. On the command—

**SQUADRON
 ABOUT – TURN**

- The entire squadron is to turn about.

- b. When a squadron is in close column, column of flights, or in line, officers in front of their flights are to turn to the right and supernumeraries are to turn to the left and gain their new positions by marching round the flanks of their flights in quick time. When the order is given on the march, officers and supernumeraries are to gain their new positions in double time.
- c. When a squadron turns into line from column of threes and the supernumeraries are to change positions after the turn as laid down above.
- d. When a squadron is required to fall back for a short distance in order to resume the original front, the precautionary command is given—
- SQUADRON WILL RETIRE**
- e. When the squadron is again required to turn about, the precautionary command is given—
- SQUADRON WILL ADVANCE**
- f. In each instance the FLTCDRs and supernumeraries are to retain their positions.
- g. The PCDR gives the executive commands for the movements to be carried out simultaneously by flights.
- h. When a squadron is required to halt as soon as a change of formation has been completed, the command is preceded by the precautionary—
- AT THE HALT**
- i. Movements of a squadron from close column of flights to column of threes or route are carried out from halt to move, and movements from column of threes or route to close column of flights from move to halt.
- j. A squadron may consist of two or more flights. The instructions contained in [Part 3 Ceremonial Drill](#) are for a squadron consisting of three flights, but they also apply to a squadron consisting of any other number of flights.

Chapter 4 – Squadron Parade Procedure

2.4.1 Preliminary

- a. The squadron is to assemble at the predetermined assembly area five minutes before the time laid down for the parade.
- b. The squadron is to form up in line, with No.1 Flight on the left.
- c. Flight roll calls are conducted by the flight sergeants (F/Ss) as soon as flights are formed up.
- d. The squadron warrant officer (SWO) informally attains the flight strengths from the F/Ss.
- e. The SWO is to establish beforehand where the marker of No.1 Flight is to stand once the squadron is marched on.

2.4.2 Parade formation

- a. The squadron parade is formed up as shown in Table [2-4-1](#).
- b. The distances for close column markers are listed in Table [2-4-2](#).

Table 2-4-1 Squadron Parade Form Up Procedure

| Serial | Commander | Command | Action |
|--------|-----------|--|---|
| 1 | | | The SWO takes up position approximately three paces from the mark and then turns to face the squadron waiting to march on. |
| 2 | SWO | SQUADRON MARKERS | <ul style="list-style-type: none"> – The markers for each flight— – come to attention; – march out; and – report to the SWO. – The markers form up so that— – the No.1 Flight marker is three paces in front of the SWO; and – the remaining markers, in order of flights, are on the right of No.1 Flight marker. – The markers stand at ease. – The SWO remains facing the squadron. |
| 3 | SWO | MARKERS MARKERS – SHUN WITHOUT INTERVALS LEFT – DRESS EYES – FRONT NUMBER | <ul style="list-style-type: none"> – Markers call out the number of their flights. |

UNCLASSIFIED

NZAP 2.4 Manual of Ceremonial and Drill
 Part 2 – Formation Drill
 Chapter 4 – Squadron Parade Procedure

Version 6.00
 13 June 2023

| Table 2-4-1 Squadron Parade Form Up Procedure (cont.) | | | |
|--|---|---|--|
| Serial | Commander | Command | Action |
| 4 | SWO | OUTWARDS – TURN | <ul style="list-style-type: none"> – No.1 Flight marker turns left. – The rest of the markers turn right. |
| 5 | The SWO details the number of paces each marker is to march to achieve close column distance. (Refer to Table 2-4-2). | | |
| 6 | SWO | INTO CLOSE COLUMN DISTANCE QUICK MARCH | <ul style="list-style-type: none"> – No.1 Flight marker stand fasts – The rest of the markers march forward the nominated number of paces. – Each marker halts at the correct distance and remains facing the rear until the marker of the rear flight is in position. – Working together, and in time with the rear marker, markers turn about and cover off No.1 Flight marker. |
| 7 | The SWO covers off the markers front to rear. | | |
| 8 | SWO | STAND AT – EASE | <ul style="list-style-type: none"> – The SWO up takes position six paces forward and to the side of the No.1 Flight marker, from where they can best supervise the parade. |
| 9 | SWO | MARCH ON | <ul style="list-style-type: none"> – Flights, acting under the orders of their F/Ss— <ul style="list-style-type: none"> – march on to their markers; – halt; – advance; and – stand at ease. |
| 10 | SWO | SQUADRON SQUADRON – SHUN RIGHT – DRESS | <ul style="list-style-type: none"> – The squadron dress by the right. – F/Ss turn about and supervise the dressing. |
| 11 | SWO | EYES – FRONT | <ul style="list-style-type: none"> – F/Ss turn about. |
| 12 | SWO | STAND AT – EASE | <ul style="list-style-type: none"> – As the flights march on the squadron adjutant (SADJ) marches the officers onto the parade ground to a position not less than ten paces in front of the squadron. |
| 13 | SWO | OFFICERS HALT LEFT/RIGHT – TURN WITHOUT INTERVALS RIGHT – DRESS EYES – FRONT STAND AT – EASE | <ul style="list-style-type: none"> – The officers are formed up in order from right to left <ul style="list-style-type: none"> – No.1 Flight commander and supernumeraries; – No.2 Flight commander and supernumeraries; – and so on for the number of flights in the squadron. – The SWO takes up position six paces in the front centre of the squadron. |

UNCLASSIFIED

| Table 2-4-1 Squadron Parade Form Up Procedure (cont.) | | | |
|--|------------------------------------|---|---|
| Serial | Commander | Command | Action |
| 14 | SWO | SQUADRON SQUADRON – SHUN | <ul style="list-style-type: none"> - At the same time, the SAdj takes up position two paces to the rear of the SWO. - The SWO— <ul style="list-style-type: none"> - turns about; - salutes; - reports the state of the squadron; - salutes again; - turns right; and - marches by the shortest route to take up position two paces to the rear of, and covering, the right file of the leading flight. - The SWO executes a series of wheels to adopt their final position. |
| 15 | As soon as the SWO is in position— | | |
| | SWO | SQUADRON STAND AT – EASE SQUADRON SQUADRON – SHUN FALL IN THE OFFICERS | <ul style="list-style-type: none"> - Officers— <ul style="list-style-type: none"> - come to attention; - turn right; and - march to their posts by the left flanks of their flights. - FLTCDRs and F/Ss salute once. - F/Ss— <ul style="list-style-type: none"> - turn left; and - wheel into position; - halt, facing the rear in the centre of their flight, two paces to rear of the rear rank. |

UNCLASSIFIED

NZAP 2.4 Manual of Ceremonial and Drill
 Part 2 – Formation Drill
 Chapter 4 – Squadron Parade Procedure

Version 6.00
 13 June 2023

Table 2-4-1 Squadron Parade Form Up Procedure (cont.)

| Serial | Commander | Command | Action |
|--------|-----------|---------|--|
| 16 | | | <p>When the F/S of the rear flight has gained their new position—</p> <ul style="list-style-type: none"> – supernumerary officers and the F/Ss, taking their time from the rear F/S, turn about together, including the FLTCDR. – The PCDR takes up position two paces behind the SADJ. – The SADJ— <ul style="list-style-type: none"> – turns about; – salutes; – reports the parade state to the PCDR; – hands over the parade to the PCDR; – salutes again; – turns right; – marches into position two paces in front of No.1 Flight marker, – halts; and – turns about. – The PCDR takes up position where they can best supervise and exercise control over the squadron. <p>Note: The PCDR's normal position is, however, six paces in the front centre of the squadron.</p> |

Table 2-4-2 Markers Close Column Distance

| Marker | Position |
|--------------|----------------------|
| No. 1 Flight | Stand fast |
| No. 2 Flight | 11 paces or 13 paces |
| No. 3 Flight | 21 paces or 25 paces |
| No. 4 Flight | 31 paces or 37 paces |

UNCLASSIFIED

UNCLASSIFIED

NZAP 2.4 Manual of Ceremonial and Drill
 Part 2 – Formation Drill
 Chapter 4 – Squadron Parade Procedure

Version 6.00
 13 June 2023

2.4.3 Parade inspection

- a. The procedures for the squadron commander (PCDR) to inspect the squadron parade is shown in Table [2-4-3](#).

Table 2-4-3 Procedure for Squadron Parade Inspection by Squadron Commander

| Serial | Commander | Command | Action |
|--|--|---|--|
| 1 | PCDR | SQUADRON IN OPEN ORDER RIGHT – DRESS EYES – FRONT | <ul style="list-style-type: none"> – The PCDR details their intentions for the inspection, for example— 'I will inspect Numbers.1, 2 and 3 Flights, Numbers 2 and 3 Flight commanders stand your flights at ease.' – The PCDR's intentions are acknowledged by salutes from the FLTCDRs. – Each FLTCDR— <ul style="list-style-type: none"> – - faces their flight; – - stands their flight at ease; and – - calls their flight to attention on the approach of the PCDR. – The FLTCDR then— <ul style="list-style-type: none"> – - marches to the right flank; – - salutes; and – - reports their flight ready for inspection. – After the inspection of each flight is completed, the FLTCDR stands their flight at ease |
| <p>Note: The inspecting party consists of the PCDR, accompanied one pace on their front (two o'clock position) by the FLTCDR of the flight being inspected. Following two paces to the rear of the PCDR is the SWO with the SADJ one pace on their right at about the two o'clock position.</p> | | | |
| 2 | At the completion of the inspection of the squadron— | | |
| | PCDR | SQUADRON SQUADRON – SHUN IN CLOSE ORDER RIGHT – DRESS EYES – FRONT | |

UNCLASSIFIED

UNCLASSIFIED

NZAP 2.4 Manual of Ceremonial and Drill
 Part 2 – Formation Drill
 Chapter 4 – Squadron Parade Procedure

Version 6.00
 13 June 2023

- b. Alternatively the procedure for the PCDR to delegate the inspection of flights to the respective FLTCDRs is shown in Table [2-4-4](#).

Table 2-4-4 Alternative Procedure for Squadron Parade Inspection by Squadron Commander

| Serial | Commander | Command | Action |
|--------|-----------|--|--|
| 1 | PCDR | FLIGHT COMMANDERS INSPECT YOUR OWN FLIGHTS CARRY ON | <ul style="list-style-type: none"> - The FLTCDRs— <li style="padding-left: 20px;">- salute; <li style="padding-left: 20px;">- take two paces forward; <li style="padding-left: 20px;">- turn about; and <li style="padding-left: 20px;">- prepare their flights for inspection as in flight drill. - The FLTCDRs carry out the inspection of their flights accompanied by their F/S. - The F/S takes up position one pace to the right front of the FLTCDR during the inspection. - At the conclusion of the inspection the F/S returns to their normal position. - No salutes are exchanged. - When the inspection has been completed, FLTCDRs will close order and dress the flights as in flight drill. |

2.4.4 Dismissing a squadron

The procedure for dismissing a squadron from a squadron parade is shown in Table [2-4-5](#).

UNCLASSIFIED

Table 2-4-5 Procedure for Dismissing a Squadron Parade

| Serial | Commander | Command | Action |
|--------|--|---|---|
| 1 | PCDR | SQUADRON STAND AT – EASE FALL OUT THE OFFICERS | <ul style="list-style-type: none"> – The SADJ marches out to a position one pace to the right rear of the PCDR. – The officers of each flight— <ul style="list-style-type: none"> – turn left; – march out in quick time; – halt in a semi-circle facing the PCDR at a distance of three paces away with— <ul style="list-style-type: none"> – No.1 Flight commander first with their supernumeraries on their left; – No.2 Flight commander with their supernumeraries on the left of the No. 1 Flight commander; and so on. – No.1 Flight commander takes one pace forward. – When all officers are in position, they salute together. |
| 2 | After the compliment has been returned by the PCDR, No.1 Flight commander— <ul style="list-style-type: none"> – takes one pace to the rear; – orders the officers to turn right; – leads the officers off the parade ground; and – dismisses the officers when clear of the parade ground. | | |
| 3 | The PCDR calls for the SWO who reports to the PCDR and salutes. | | |
| 4 | The PCDR gives the orders for the dismissal of the squadron. | | |
| 5 | The SWO salutes and takes up a position in the front centre of the squadron. | | |
| 6 | At the same time, the F/Ss, acting on the order 'Fall Out the Officers'— <ul style="list-style-type: none"> – turn left; – march around the left flank of their flights; – halt facing the right flank; – turn left; and – stand at ease carrying out all movements in unison. | | |
| 7 | SWO | SQUADRON SQUADRON – SHUN F/SS CARRY ON | <ul style="list-style-type: none"> – F/Ss take command of their flights and either <ul style="list-style-type: none"> – - dismiss them from the parade ground; or – - march them off to a predetermined area from where they are dismissed. |

UNCLASSIFIED

NZAP 2.4 Manual of Ceremonial and Drill
 Part 2 – Formation Drill
 Chapter 4 – Squadron Parade Procedure

Version 6.00
 13 June 2023

2.4.5 Movements in column of threes

- a. The commands and movements to be used for a squadron in column of threes when reforming as a column of flights (or close column of flights) facing a flank are shown in Table [2-4-6](#).

Table 2-4-6 Movements in Column of Threes

| Serial | Commander | Command | Action |
|--|--------------------------|--|--|
| Forming column of flights (or close column of flights) facing a flank | | | |
| 1 | PCDR | SQUADRON AT THE HALT FACING LEFT FORM COLUMN OF FLIGHTS/ CLOSE COLUMN OFFLIGHTS | |
| 2 | FLTCDR of leading flight | NUMBER....FLIGHT HALT FLIGHT WILL ADVANCE.... LEFT – TURN | – Each of the remaining flights is led by its guide and marker by the shortest way to its position in column of flights/close column of flights. |
| 3 | FLTCDR of each flight | NUMBER ... FLIGHT - HALT | – The marker of each flight— – turns to the left; and – takes up covering and distance from the right guide and marker of the flight in front. – The covering and dressing are supervised by the SWO. |
| 4 | FLTCDR of each flight | FLIGHT WILL ADVANCE LEFT – TURN | Note: This movement may be carried out facing right, when the word 'RIGHT' is substituted for 'LEFT', and vice versa. |
| Advance in column | | | |
| 1 | PCDR | SQUADRON FACING LEFT/RIGHT ADVANCE IN COLUMN | Note: This movement may be carried out facing right, when the word 'RIGHT' is substituted for 'LEFT', and vice versa |
| 2 | FLTCDR of leading flight | NUMBER ... FLIGHT WILL ADVANCE LEFT/RIGHT - TURN | – When the turn has been completed, the FLTCDR of the leading flight advises the new flank of direction. |
| 3 | FLTCDR of leading flight | BY THE RIGHT/LEFT | – Each of the remaining flights, as they arrive at the alignment/point on/at which the leading flight turned, acts in the same way. |
| Forming column of flights (or close column of flights) facing the front | | | |
| 1 | PCDR | SQUADRON AT THE HALT ON THE LEFT/RIGHT) FORM COLUMN OF FLIGHTS/ CLOSE COLUMN OF FLIGHTS | |

UNCLASSIFIED

UNCLASSIFIED

NZAP 2.4 Manual of Ceremonial and Drill
 Part 2 – Formation Drill
 Chapter 4 – Squadron Parade Procedure

Version 6.00
 13 June 2023

| Table 2-4-6 Movements in Column of Threes (cont.) | | | |
|--|---------------------------|--|--|
| Serial | Commander | Command | Action |
| 2 | FLTCDR of leading flight | NUMBER ... FLIGHT AT THE HALT ON THE LEFT/RIGHT FORM – FLIGHT | <ul style="list-style-type: none"> – The flight acts as in flight drill. – The FLTCDR moves directly into their position two paces in the centre front of their flight, facing the front. – The F/S and supernumeraries— <ul style="list-style-type: none"> – halt with the flight; – pause; – turn about; – march to their respective positions as for a flight in line; – halt; and – turn to the front together. – The SADJ moves by the shortest route to their position two paces in front of the leading file of the leading flight. – Supernumeraries and the F/S act independently by flights. – Successive FLTCDRs act similarly when they reach column (or close column) distance. – The SWO steps out the distance and markers automatically pick up their alignment. |
| Advance in column (while advancing in column of threes) | | | |
| 1 | PCDR | SQUADRON WILL ADVANCE IN COLUMN FLIGHTS ON THE LEFT FORM – FLIGHT | <ul style="list-style-type: none"> – Flights act as in flight drill. – Officers and NCOs move to their positions by the shortest route. |
| 2 | When all are in position— | | |
| | PCDR | FOR - WARD | |

UNCLASSIFIED

UNCLASSIFIED

2.4.6 Movements of a squadron in close column of flights

The commands and movements of a squadron in close column of flights are shown in Table [2-4-7](#).

Table 2-4-7 Movements of a Squadron in Close Column of Flights

| Serial | Commander | Command | Action |
|---|--------------------------|---|---|
| Advancing | | | |
| 1 | PCDR | SQUADRON BY THE RIGHT/LEFT QUICK - MARCH | |
| Retiring and at the end of the retirement | | | |
| 1 | PCDR | SQUADRON WILL RETIRE ABOUT - TURN SQUADRON WILL ADVANCE ABOUT - TURN | |
| Moving to a flank with flights in threes | | | |
| 1 | PCDR | | |
| Forming column of threes moving to a flank | | | |
| 1 | PCDR | SQUADRON MOVE TO THE RIGHT/LEFT IN COLUMN OF THREES RIGHT/LEFT – TURN | |
| 2 | FLTCDR of leading flight | NUMBER... FLIGHT LEFT WHEEL BY THE LEFT QUICK – MARCH | Note: Unless ordered, a squadron in close column of flights moves to the right in column of threes from the right of the leading flight, and moves to the left from the left of the rear flight. A squadron may, however, be moved to a flank in column of threes in any order of flights specified by the PCDR. |
| Forming column of route, moving to a flank | | | |
| 1 | PCDR | SQUADRON, MOVE TO THE RIGHT/LEFT IN COLUMN OF ROUTE RIGHT/LEFT - TURN | – The detail is the same as for column of threes, except that officers, W/Os and NCOs take up positions as for column of route after turning and before the flight moves off. |
| Advancing or retiring in column of threes | | | |
| 1 | PCDR | SQUADRON ADVANCE/RETIRE IN COLUMN OF THREES FROM THE RIGHT/LEFT RIGHT/LEFT – TURN | |
| 2 | FLTCDR of leading flight | NUMBER ... FLIGHT LEFT WHEEL BY THE LEFT QUICK - MARCH | |

UNCLASSIFIED

UNCLASSIFIED

| Table 2-4-7 Procedure for Squadron Parade Inspection by Squadron Commander (cont.) | | | |
|---|--|---|---|
| Serial | Commander | Command | Action |
| 3 | FLTCDR of each following flight | NUMBER ... FLIGHT LEFT WHEEL BY THE LEFT QUICK - MARCH | <ul style="list-style-type: none"> – This command is given in sufficient time to take up their place in column of threes <p>Note: Unless otherwise ordered, a squadron in close column of flights advances in column of threes from the right of the leading flight and retires from the left of the rear flight. A squadron may, however, advance/retire in column of threes in any order of flights as specified by the PCDR.</p> |
| Advancing or retiring in column of route | | | |
| 1 | PCDR | SQUADRON ADVANCE/RETIRE IN COLUMN OF ROUTE FROM THE RIGHT/LEFT RIGHT/LEFT – TURN | Note: The detail is the same as for column of threes, except that officers, W/Os and NCOs take up their positions for column of route after turning and before the flight moves off. |
| Forming line from close column of flights facing the same direction when halted | | | |
| 1 | PCDR | SQUADRON ON THE LEFT FORM LINE REMAINDER MOVE TO THE LEFT IN THREES LEFT - TURN BY THE RIGHT QUICK MARCH | <ul style="list-style-type: none"> – The leading flight stands fast. – The remaining flights turn as ordered. – Each of the remaining flights is led by the left guide and marker by the shortest way to the position where it will be on the same alignment. |
| 2 | When each flight reaches its position in line— | | |
| | Each FLTCDR | NUMBER ... FLIGHT - HALT FLIGHT WILL ADVANCE RIGHT - TURN | |
| Advancing in column | | | |
| 1 | PCDR | SQUADRON ADVANCE IN COLUMN | |
| 2 | FLTCDR of leading flight | NUMBER ... FLIGHT BY THE RIGHT QUICK MARCH | <ul style="list-style-type: none"> – Each of the remaining flights marches off in a similar manner when the flight next in front has reached column distance. |
| 3 | FLTCDR of each following flight | NUMBER ... FLIGHT BY THE RIGHT QUICK MARCH | |

UNCLASSIFIED

UNCLASSIFIED

NZAP 2.4 Manual of Ceremonial and Drill
 Part 2 – Formation Drill
 Chapter 4 – Squadron Parade Procedure

Version 6.00
 13 June 2023

2.4.7 Movements of a Squadron in Column of Flights

The commands and movements for a squadron in column of flights are shown in Table [2-4-8](#).

Table 2-4-8 Movements of a Squadron in Column of Flights

| Serial | Commander | Command | Action |
|--|--|---|--------|
| Closing to close column of flights | | | |
| 1 | PCDR | SQUADRON AT THE HALT FORM CLOSE COLUMN OF FLIGHTS | |
| 2 | FLTCDR of leading flight | NUMBER ... FLIGHT - HALT | |
| 3 | If/when the movement is carried out on the march | | |
| | PCDR | SQUADRON FORM CLOSE COLUMN OF FLIGHTS REMAINDER DOUBLE –MARCH | |
| 4 | When their flight has arrived at the correct distance— | | |
| | | NUMBER ... FLIGHT INTO QUICK TIME QUICK - MARCH | |
| 5 | Close columns of flights can be formed at a specified number of paces distance with the following command— | | |
| | PCDR | SQUADRON FORM CLOSE COLUMN OF FLIGHTS AT ... PACES | |
| Forming column of route (or threes) | | | |
| 1 | PCDR | SQUADRON ADVANCE/RETIRE IN COLUMN OF ROUTE/THREES FROM THE RIGHT/LEFT RIGHT/LEFT - TURN FLIGHTS LEFT WHEEL BY THE LEFT QUICK – MARCH | |
| 2 | When a squadron is marching in a column of flights and flights are ordered to advance in column of route/threes in succession— | | |
| | PCDR | SQUADRON IN SUCCESSION ADVANCE/RETIRE IN COLUMN OF ROUTE/THREES | |

UNCLASSIFIED

UNCLASSIFIED

| Table 2-4-8 Movements of a Squadron in Column of Flights (cont.) | | | |
|--|---|--|--|
| Serial | Commander | Command | Action |
| 3 | FLTCDR of leading flight | NUMBER ... FLIGHT MOVE TO THE RIGHT IN THREES RIGHT - TURN CHANGE DIRECTION LEFT LEFT – WHEEL | |
| 4 | FLTCDR of each following flight | NUMBER ... FLIGHT MOVE TO THE RIGHT IN THREES RIGHT - TURN CHANGE DIRECTION LEFT LEFT – WHEEL | – Command given when their flight arrives at the same position where the Leading flight turned. |
| Note: Unless otherwise ordered, a squadron in column of flights advances in column of route/threes in succession from the right of the leading flight and retires from the left of the rear flight. | | | |
| 5 | If/when flights are to be moved in succession to the right/left in column of route/threes | | |
| | PCDR | SQUADRON IN SUCCESSION MOVE TO THE RIGHT/LEFT IN COLUMN OF ROUTE/THREES | |
| Forming line facing the same direction | | | |
| 1 | PCDR | SQUADRON ON THE LEFT FORM LINE REMAINDER LEFT IN - CLINE QUICK - MARCH | <ul style="list-style-type: none"> – The leading flight stands fast. – The remaining flights act as in squadron drill. |
| 2 | When each flight arrives at the rear of its position in line— | | |
| | FLTCDR of each flight | NUMBER ... FLIGHT RIGHT IN - CLINE | |
| 3 | When each flight reaches its alignment— | | |
| | FLTCDR of each flight | NUMBER ... FLIGHT - HALT | |
| 4 | When a squadron is marching in column of flights | | |
| | PCDR | SQUADRON ON THE LEFT FORM LINE REMAINDER LEFT IN - CLINE DOUBLE - MARCH | <ul style="list-style-type: none"> – The leading flight continues to advance in quick time – The following flights act as ordered. |
| 5 | When each flight reaches the alignment— | | |
| | Each FLTCDR | NUMBER ... FLIGHT RIGHT IN - CLINE INTO QUICK TIME QUICK - MARCH | – Given instead of 'HALT' |

UNCLASSIFIED

UNCLASSIFIED

NZAP 2.4 Manual of Ceremonial and Drill
 Part 2 – Formation Drill
 Chapter 4 – Squadron Parade Procedure

Version 6.00
 13 June 2023

| Table 2-4-8 Movements of a Squadron in Column of Flights (cont.) | | | |
|--|-----------------------|---|--|
| Serial | Commander | Command | Action |
| Movements in line | | | |
| – When a squadron is in line it may be ordered to carry out movements as for squad and flight drill. | | | |
| Forming column of flights or close column of flights facing the same direction when halted | | | |
| 1 | PCDR | SQUADRON ON THE RIGHT FORM COLUMN OF FLIGHTS/ CLOSE COLUMN OF FLIGHTS REMAINDER RIGHT - TURN BY THE LEFT QUICK - MARCH | <ul style="list-style-type: none"> – The flight on the right stands fast. – Each of the remaining flights is led by the right guide and marker by the shortest way to its position in column of flights/close column of flights. |
| 2 | FLTCDR of each flight | NUMBER ... FLIGHT HALT | – The marker of each flight turns left and takes covering and distance from the right guide and marker of the flight in front. |
| 3 | FLTCDR of each flight | FLIGHT WILL ADVANCE LEFT - TURN | Note: The covering and dressing are supervised by the SWO. |

UNCLASSIFIED

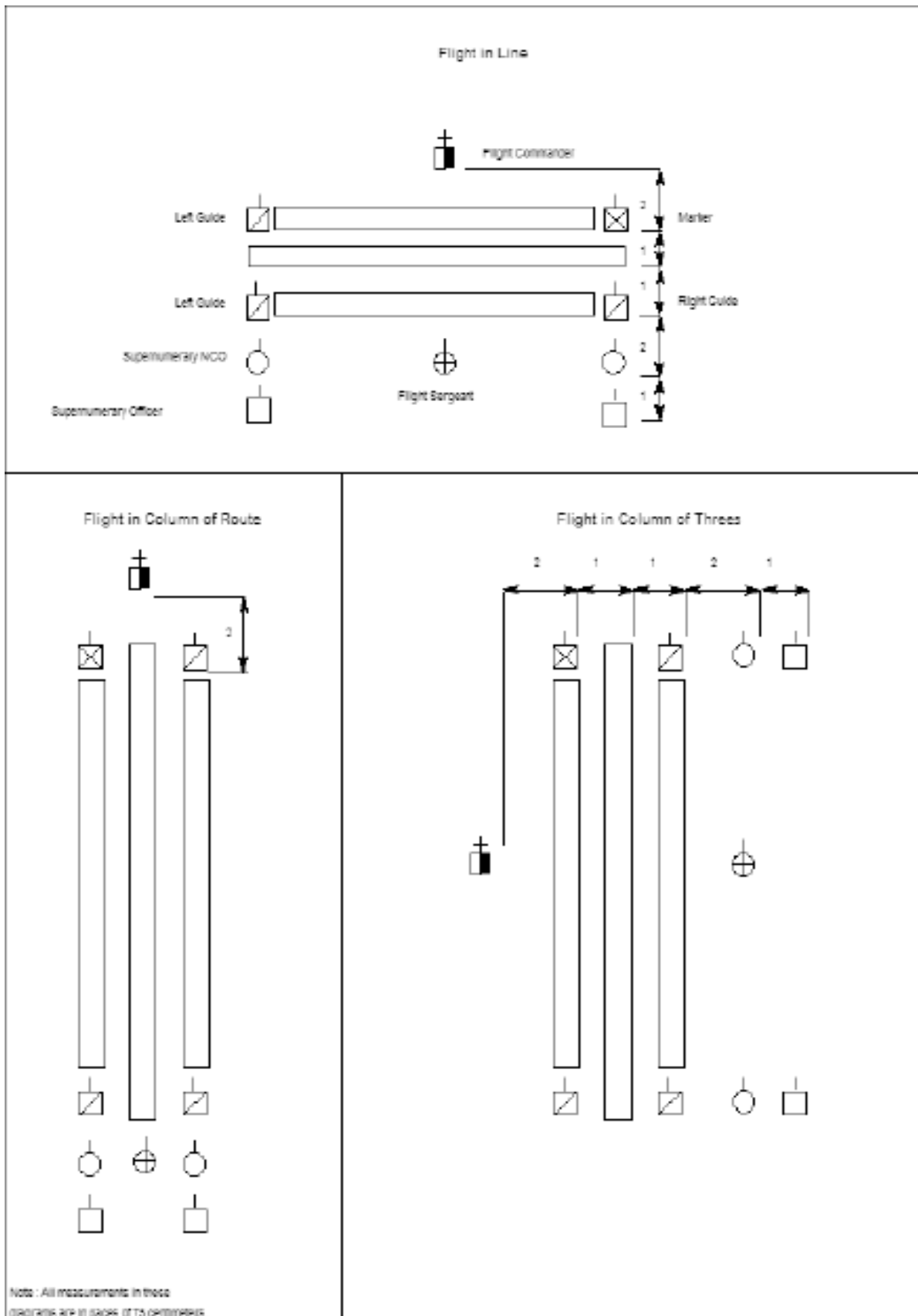

Figure 2-4-1 Squadron in Close Column of Flights

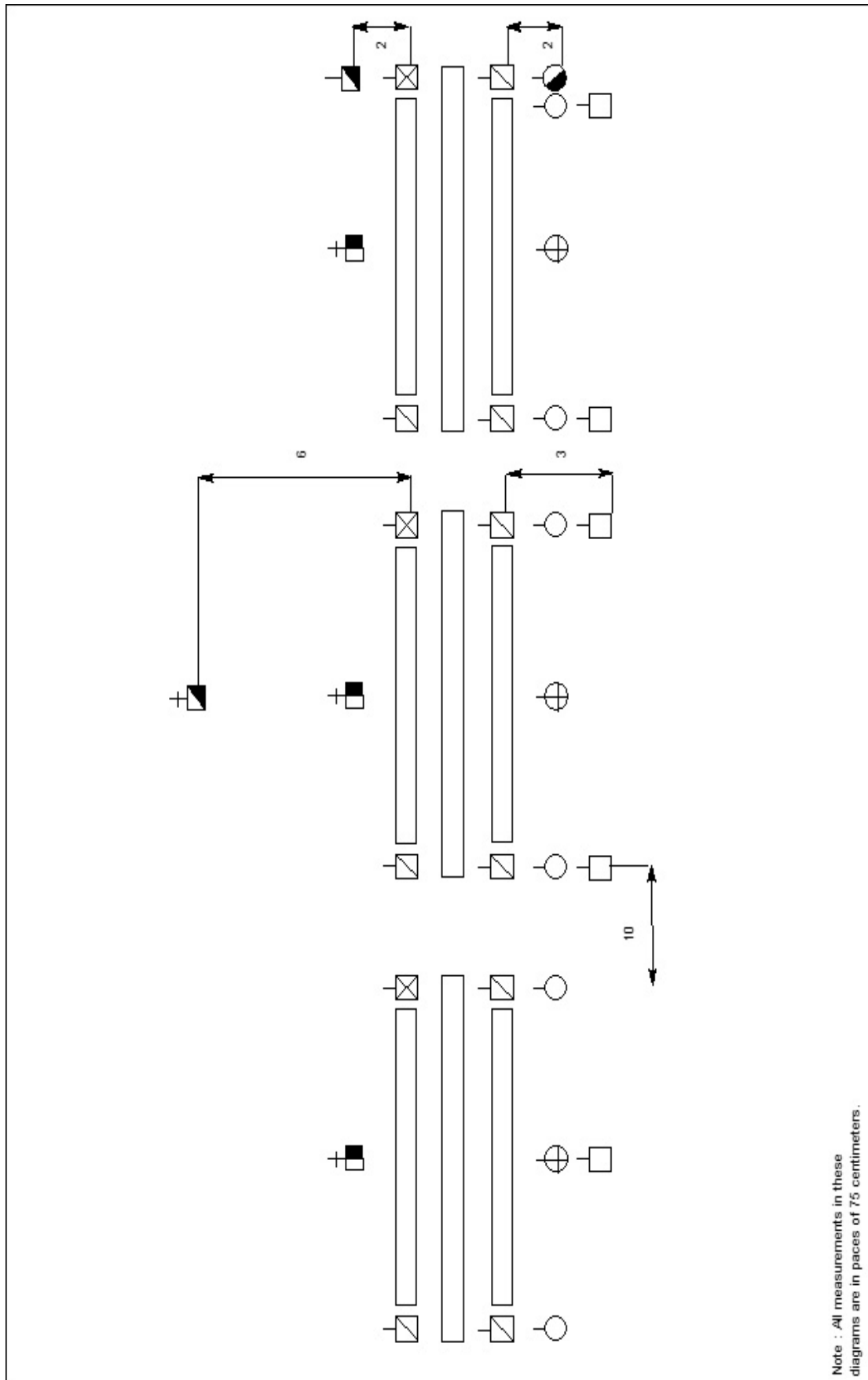

Figure 2-4-2 Squadron in Line

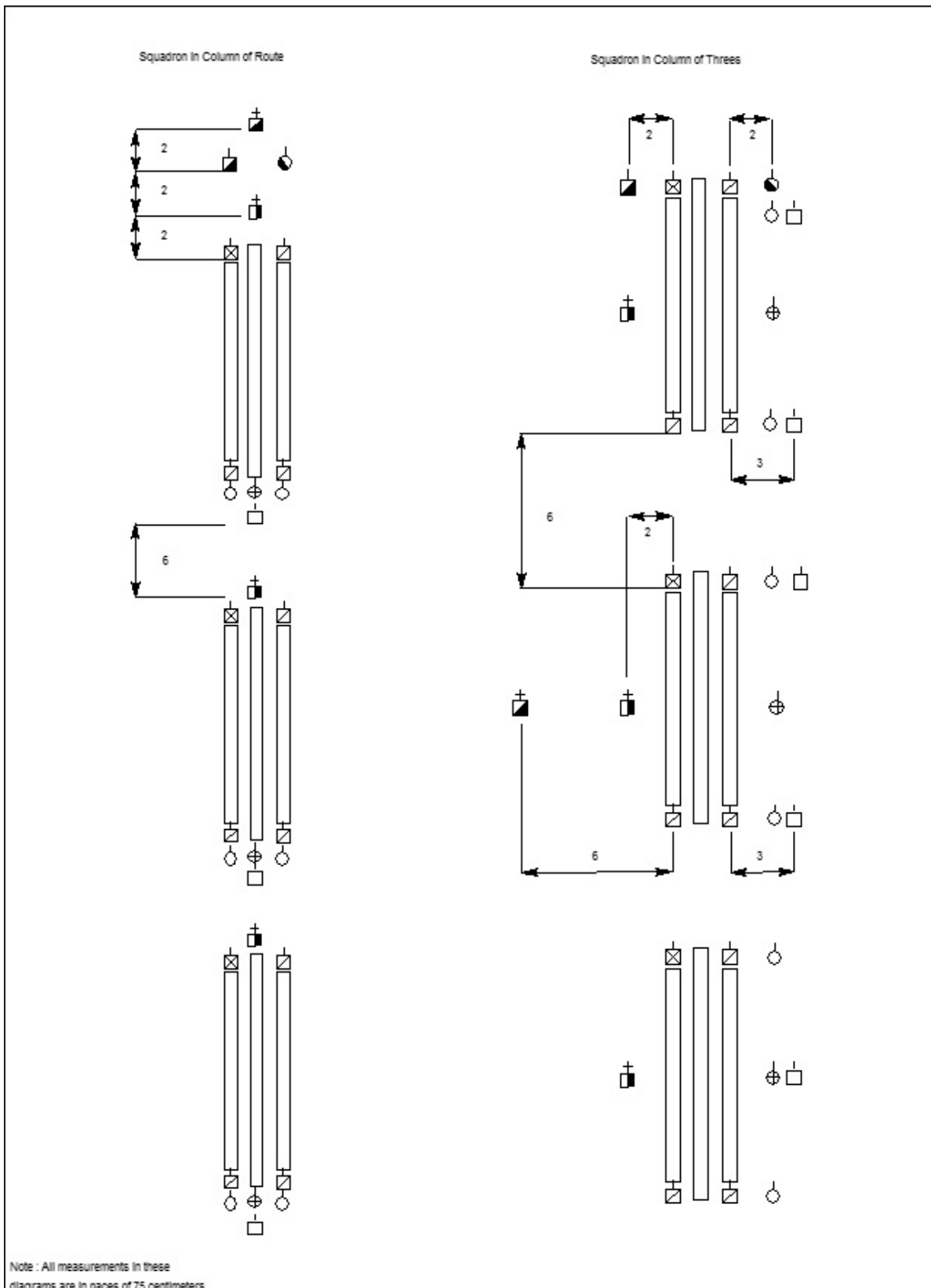

Figure 2-4-3 Squadrons in Column of Route and Column of Threes

Chapter 5 – Wing Drill

2.5.1 Object of wing drill

The object of wing drill is to coordinate the movements of two or more squadrons under the command of a wing commander.

2.5.2 Formations

- a. The wing may be formed up as detailed in Table [2-5-1](#).
- b. Unless otherwise ordered, a wing forms up in line of squadrons in close column of flights and dresses by the right flank.
- c. The positions of officers, warrant officers (W/Os) and non-commissioned officers (NCOs) when a wing is formed up are shown in Table [2-5-2](#).
- d. When a single wing is exercising, the wing commander takes up a position from which they can supervise to the best advantage.
- e. In line of squadrons in close column of flights, when flights are of unequal strength, the inner flank of the squadron is to be at 10 paces interval from the outer flank of the strongest flight of the squadron next to it.

2.5.3 Dressing

- a. When it is necessary to correct the dressing of a wing—
 - (1) The wing commander gives the command—
WING
RIGHT/LEFT – DRESS
 - Squadron commanders (SCDRs) and flight commanders (FLTCDRs) and the wing adjutant (WADJ) and squadron adjutants (SADJs) turn about and dress their squadrons/flights.
 - (2) The wing commander gives the command—
EYES – FRONT
 - PCDRs and FLTCDRs and wing and SADJs turn to the front.
- b. The dressing of a wing is carried out as follows—
 - (1) Close column of squadrons. Each squadron dresses on the guide and marker on the flank of direction.
 - (2) Line of squadrons in close column of flights—
 - (a) Each flight of each squadron dresses on the guide and marker on the flank of direction.
 - (b) Successive flights cover off the leading flight.

Table 2-5-1 Wing Formations

| Command | Action |
|---------------------------|--|
| Close column of squadrons | Squadrons in line on parallel and successive alignment at 18 paces distance. |
| Line of squadrons | Squadrons in close column of flights on the same alignment at 10 paces interval. |
| Column of route/threes | Squadrons in column of route/threes with 10 paces distance between squadrons. |

- c. When a wing is marching, the guides and markers are responsible for maintaining the direction and dressing as in squadron drill.

On the command—

ABOUT – TURN

- The entire wing turns about.

- d. When a wing is in column of squadrons or line of squadrons in close column of flights—
- (1) officers in front of the squadrons/flights turn to the right;
 - (2) supernumeraries turn to the left; and
 - (3) officers and supernumeraries all attain their new positions by marching in quick time round the flank of their squadron or flight.
- e. When the order is given on the march, officers and supernumeraries attain their new positions by marching in double time.

2.5.4 Responsibility for words of command

- a. The wing commander is responsible for giving the executive commands for movements to be carried out simultaneously by squadrons or flights.
- b. When a movement is to be carried out by squadrons in succession, the wing commander gives their command and PCDRs, unless marching or about to advance—
- (1) turn about;
 - (2) face their squadrons; and
 - (3) give the executive command.

2.5.5 Change of formation

- a. When a wing is required to halt as soon as a change of formation has been completed, the command is to be preceded by the precautionary—

AT THE HALT

- b. If a change of formation is initiated when a unit is already on the march, the command 'QUICK MARCH' is to be omitted.

Table 2-5-2 Officer and Supernumerary NCO Positions

| Formation | Personnel | Position |
|--|---|---|
| Close column of squadrons | Wing commander | 20 paces in front of the centre of the leading squadron (14 paces in front of the commander of the leading squadron). |
| | WADJ | Six paces in front of the file on the right of the leading squadron (in line with the PCDR). |
| | WWO | Four paces in rear of the right file of the flight on the right of No.1 Squadron. |
| | The remaining officers, W/Os and NCOs are positioned as laid down for a squadron in line. | |
| Line of squadrons in close column of flights | Wing commander | |
| | WADJ | |
| | WWO | |
| | The remaining officers, W/Os and NCOs are positioned as laid down for a squadron in close column of flights. | |
| Column of route | Wing commander | |
| | WADJ | |
| | SWO | |
| | The remaining officers, W/Os and NCOs are to be in the positions laid down for a squadron in Column of Route. | |
| Column of threes | Officers, W/Os and NCOs are positioned as laid down for a squadron in line. | |

2.5.6 Movements of a wing from column of route/threes to column of squadrons

- a. The movement of a wing from column of route/threes to column of squadrons can be carried out only from move to halt.
- b. The movement of a wing from column of squadrons to column of route/threes can be carried out only from halt to move.

2.5.7 Procedure for wing fall-in

Where wing parades are preceded by squadron parades, and in some cases by flight parades, it is considered unnecessary to follow the full procedure. For regular base parades on Royal New Zealand Air Force (RNZAF) bases, therefore, an alternative is normally to be used. The alternative procedure, designed to meet all the requirements of a wing parade but with considerable saving in time, is detailed in paragraph [2.5.9](#). The full procedure described in paragraph [2.5.8](#) may be adopted by RNZAF units for such parades as the base commander may consider necessary.

2.5.8 Full procedure

- a. Squadrons parade on predetermined assembly areas before marching on to the wing parade ground.

UNCLASSIFIED

NZAP 2.4 Manual of Ceremonial and Drill
 Part 2 – Formation Drill
 Chapter 5 – Wing Drill

Version 6.00
 13 June 2023

- b. The marker of No. 1 Flight of each squadron reports to the wing warrant officer (WVO) five minutes before the time laid down for the wing parade to begin, with the strength of their squadrons and preferably with the frontage of the largest flight of the squadron.
- c. Markers form up so that No.1 Squadron marker is three paces in front of the WVO and the remaining markers in order of squadrons on the left of No.1 Squadron marker.
- d. The wing orderly sergeant (WOS)—
- (1) falls in, in line with and on the right of, the line of markers, once pace from No.1 Squadron marker; and
 - (2) stands at ease.
- e. The WVO gives the command—
- MARKERS**
RIGHT – DRESS
- Markers dress shoulder to shoulder.
- f. The WVO then gives the command—
- EYES – FRONT**
NUMBER
- The markers number from the right, as in squad drill.
- g. The WVO gives the command—
- OUTWARDS – TURN**
- No.1 Squadron marker and the WOS to turn right.
 - The remaining markers turn left.
- h. The WVO gives the command—
- PACES, QUICK – MARCH**
- No.1 Squadron marker stands fast.
 - The WOS—
 - marches forward five paces;
 - Halts; and
 - turns about.
 - The remaining markers march forward the nominated number of paces, representing the frontage of the squadron, plus ten paces.
 - Each marker halts at the correct distance and remains facing the left flank until the last marker has halted.
 - Working together, markers turn about and are dressed by the WOS.

i. The WWO then gives the command—

MARKERS – STEADY

- The WOS turns right.
- The markers turn left and stand at ease in unison.

j. If available, the band—

- Falls in at the same time as the markers on the right of the wing with the left flank of the band ten paces clear of, and in line with, the front rank of the second flight of the squadron on the right.
- Starts playing on the approach of the squadrons.
- Ceases playing on arrival in position of the last squadron.
- The trumpeter sounds the ‘Advance’.
- The WWO and the WOS march along the right flank of the parade with the WWO five paces out from the flank of No.1 Squadron position accompanied by the WOS one pace further from the flank of the parade.
- When marching towards the retire and about turn, the band turns left about (in accordance with history).
- When turning about from the advance, the band performs another about turn, which is the normal right about turn.

k. On the sound of the ‘Advance’, PCDRs—

- march their squadrons on to the wing parade ground; and
- halt on the squadron marker in close column of flights.

l. The squadron marker comes to attention as the squadron approaches.

Note: Squadrons are not to march across the area to be occupied by another squadron when marching onto the wing parade ground.

m. When the squadron has halted, each PCDR gives the commands—

NO..... SQUADRON

RIGHT – DRESS

EYES – FRONT

STAND AT – EASE

FALL OUT THE OFFICERS

- The officers come to attention.
- Supernumerary officers turn left.
- Then all officers step off together.
- Supernumerary officers and the officers of No.2 Flight and any other following flights, move by the outer flank of the squadron.

- On the command ‘FALL OUT THE OFFICERS’, the PCDR turns about and the remaining officers halt in position on the PCDR’s right in the following order—
 - (a) The SADJ.
 - (b) No.1 Flight commander and supernumerary officers.
 - (c) No.2 Flight commander and supernumerary officers, and so on.

- n. When all officers have arrived in position, the PCDR gives the command—

QUICK – MARCH

 - Officers march forward in line until given the command ‘HALT’ by the PCDR at a predetermined line twenty paces in front of the squadron.

- o. The PCDR gives the commands—

ABOUT – TURN

STAND AT – EASE

 - The squadron warrant officers (SWOs) and flight sergeants (F/Ss) of each squadron march to the positions vacated by the PCDR and FLTCDRs.

- p. The PCDR gives the command

FALL OUT THE OFFICERS

 - The F/Ss move by the outer flank.
 - The SWO moves by the inner flank.
 - When all officers are in position, the WWO and the WOS cease marching up and down the flank of the parade ground.
 - The WWO take up position 15 paces in the front centre of the wing, facing the parade.
 - The WOS takes up a position six paces on the right of, and in line with, the front rank of No.1 Squadron.

- q. The WWO gives the command—

WING

FALL – IN

 - The markers of each flight of the wing, the SWOs and the WOS—
 - come to attention; and
 - take one pace forward.
 - The markers and SWOs—
 - turn right; and
 - the WOS turns left.
 - The SWOs, taking their time from No.1 Squadron W/O—
 - march forward five paces;
 - halt; and
 - turn right.

- The SWOs dress their own markers from front to rear.
 - The WOS—
 - covers the designated close column distance;
 - halts;
 - turns right;
 - dresses the No.2 Flight markers of the wing;
 - turns left; and
 - dresses the other flights of the wing in the same manner.
 - When all markers have been dressed, the WOS—
 - turns right
 - marches back to their position six paces out from, and in line with, the marker of No.1 Flight of No.1 Squadron;
 - halts; and
 - turns left.
- r. The WWO gives the command—
- STEADY**
- The flight markers and the WOS turn to the front.
 - The SWOs turn right.
 - Taking their time from the furthest SWO, the SWOs—
 - march forward five paces;
 - halt; and
 - turn right.
 - The SWOs and the WOS stand at ease together.
- s. The WWO gives the command—
- RIGHT – DRESS**
- The remainder of the wing—
 - come to attention;
 - take one pace forward; and
 - dress by the right.
 - The right files of each flight are responsible for covering and distance.
 - The right files of all flights, other than those in No.1 Squadron, turn their head and eyes to the right during the wing right dress.
 - SWOs, with the F/Ss, turn about and supervise the dressing.
 - The WOS turns inwards and again checks the dressing of the front ranks of the flights from the flank.

UNCLASSIFIED

NZAP 2.4 Manual of Ceremonial and Drill
 Part 2 – Formation Drill
 Chapter 5 – Wing Drill

Version 6.00
 13 June 2023

- On completion of the dressing, the WOS resumes their position six paces out from, and in line with, the marker of No.1 Flight of No.1 Squadron, facing inwards.
- The WADJ takes up position five paces behind the WWO.

t. The WWO gives the command—

EYES – FRONT

- The wing acts as in flight drill.
- The SWOs, F/Ss and the WOS turn to the front.
- The WWO turns about and reports to the WADJ.
- On the command ‘EYES – FRONT’, the WWO—
 - salutes;
 - hands over the parade state;
 - salutes again; and
 - marches by the shortest route to take position two paces to the rear of the SWO of No.1 Squadron.
 - takes position in the same way as for squadron drill.
- The WOS, working in time with the WWO—
 - turns about; and
 - takes up position 10 paces behind the centre rear of the wing.

u. As soon as the WWO and the WOS are in position, the WADJ gives the commands—

WING**STAND AT – EASE****WING****WING – SHUN****FALL IN THE OFFICERS**

- Officers—
 - come to attention without saluting;
 - turn right; and
 - take up their positions in the wing, moving via the outer flanks of their squadrons.
- The SWOs and F/Ss—
 - salute on the arrival of the PCDRs and FLTCDRs;
 - turn right and left respectively; and
 - march by the shortest route to their positions.
- Officers, SWOs and F/Ss—
 - halt facing the rear; and
 - taking their time from the last F/S to reach position, turn about.

- The WADJ—
 - turns about;
 - salutes;
 - reports the state of the parade to the wing commander;
 - salutes again;
 - marches to their position six paces in front of the right marker of No.1 Squadron; and
 - halts facing the front after a series of wheels.
 - The wing commander takes up position 20 paces in the centre front of the wing.
- v. Subsequent orders will depend on the wing commander’s schedule.

2.5.9 Alternative procedure for wing fall-in

- a. Squadrons parade on their respective assembly areas before marching on.
- b. One marker from each squadron (No.1 Flight marker) reports to the WWO the squadron parade state five minutes before the time laid down for the wing parade.
- c. The procedure for setting out markers and the positioning of the band are the same as detailed in paragraph [2.5.8](#) for the full procedure.

Note: The SWO sets the markers out at the close column distance designated for the parade.

- d. When the markers have been set out, the trumpeter sounds the ‘Advance’.
- e. The WWO—
 - reports to the WADJ;
 - hands over the parade state;
 - joins the WOS; and
 - marches up and down the right flank of the parade.
- f. On the sounding of the ‘Advance’, PCDRs—
 - march their squadrons on to the wing parade ground; and
 - halt their squadrons in close column of flights on the squadron markers.
 - The squadron markers come to attention as the squadrons approach.

Note: Squadrons are not to march across the area to be occupied by another squadron when marching on to the wing parade ground.

- g. When their squadron is in position the PCDR of each squadron gives following commands—

NO ... SQUADRON

RIGHT – DRESS

EYES – FRONT

STAND AT – EASE

- The WADJ takes up a position approximately 20 paces in the centre front of the wing, facing the parade.
- When all squadrons are in position, the WWO and WOS cease marching up and down and take up their correct positions in the wing.

- h. When the WWO and WOS are in position the WADJ gives the command—

WING

WING – SHUN

- The WADJ—
 - turns about; and
 - reports to the wing commander who has taken up position two paces behind the WADJ.
- The WADJ—
 - salutes;
 - hands over the parade state;
 - salutes again;
 - turns right; and
 - marches to their position six paces in front of the marker of No.1 Squadron.

2.5.10 Inspection by the wing commander

- a. The wing commander may prepare the wing for inspection themselves by giving the commands—

WING

IN OPEN ORDER

RIGHT – DRESS

EYES – FRONT

STAND AT – EASE

- b. Alternatively, the wing commander may order the PCDRs to prepare their squadrons for inspection by giving the order—

SQUADRON COMMANDERS

PREPARE YOUR SQUADRONS FOR INSPECTION

UNCLASSIFIED

NZAP 2.4 Manual of Ceremonial and Drill
 Part 2 – Formation Drill
 Chapter 5 – Wing Drill

Version 6.00
 13 June 2023

c. PCDRs salute once, turn about and give the commands—

**NO ... SQUADRON
 IN OPEN ORDER
 RIGHT – DRESS
 EYES – FRONT
 STAND AT – EASE**

- As the wing commander approaches their squadron, each PCDR brings their squadron to attention and moves out to the right flank to meet the wing commander.
- During the inspection the wing commander is accompanied one pace to their right front by the PCDR. (Positions for all are similar to squadron drill).
- The WADJ follows two paces to the rear of the wing commander, with the SADJ on their right.
- The WWO follows two paces to the rear of the WADJ with the SWO on their right.
- FLTCDRs do not accompany the inspecting party.

d. If the wing commander details certain PCDRs to inspect their own squadrons, the wing commander gives the command—

**I WILL INSPECT NO.... SQUADRON(S),
 SQUADRON COMMANDER(S) OF NO(S)..... SQUADRON(S),
 INSPECT YOUR OWN SQUADRON(S)**

- The PCDRs concerned acknowledge with a salute, then carry out the inspection as detailed at the start of paragraph 2.5.10c.

e. On completion of the inspection the wing is to be closed as follows—

- (1) If the wing commander prepared the wing for inspection, each PCDR, on the completion of the inspection of their squadron by the wing commander, stands their squadron at ease.
- (2) When the inspection of the wing is completed, the wing commander gives the commands—

**WING
 WING – SHUN
 IN CLOSE ORDER
 RIGHT – DRESS
 EYES – FRONT
 STAND AT – EASE**
- (3) If the PCDRs were ordered to inspect their own squadrons, on completion of the inspection—
 - (a) The WADJ, WWO, SADJs and SWOs march back to their positions in the wing.

UNCLASSIFIED

- (b) the PCDRs—
 - (i) close order and right dress their squadrons; and
 - (ii) stand them at ease.

2.5.11 Dismissing a wing

Note: A wing is not to be dismissed on the wing parade ground but is to be marched off and squadrons are to be dismissed independently.

The wing commander gives the command—

SQUADRONS ARE TO MARCH TO THEIR OWN PARADE GROUNDS AND DISMISS

- On this command, PCDRs march their squadrons off in succession to their own designated assembly areas for the normal squadron dismissal.

2.5.12 Wing drill movements

- a. Wing in line of squadrons in close column of flights when halted, required to move to the right/left) in threes.
 - (1) The wing commander gives the commands—

**MOVE TO THE RIGHT/LEFT IN THREES
 RIGHT/LEFT – TURN
 BY THE LEFT/RIGHT
 QUICK – MARCH**
 - (2) The wing acts as in flight drill.
- b. Wing in line of squadrons in close column of flights when halted, required to move to the right/left) in column of route.
 - (1) The wing commander gives the command—

MOVE TO THE RIGHT/LEFT IN COLUMN OF ROUTE
 - (2) The PCDR of the squadron on the right/left gives the command—

**NO ... SQUADRON,
 MOVE TO THE RIGHT/LEFT IN COLUMN OF ROUTE
 RIGHT/LEFT – TURN**
 - (3) The squadron turns right/left and marches off as detailed in squadron drill.
 - (4) Successive PCDRs act similarly in time to gain position in column of route.
 - (5) A wing in line of squadrons in close column of flights normally—
 - (a) moves to the right led by the leading flight of the squadron on the right; and
 - (b) moves to the left led by the rear flight of the squadron on the left.

UNCLASSIFIED

NZAP 2.4 Manual of Ceremonial and Drill
Part 2 – Formation Drill
Chapter 5 – Wing Drill

Version 6.00
13 June 2023

- c. A wing in line of squadrons in close column of flights when halted, required to advance/retire in column of route from the right/left.
- (1) The wing commander gives the command—
**ADVANCE/RETIRE IN COLUMN OF ROUTE
FROM THE RIGHT/LEFT**
 - (2) The PCDR of the squadron on the right/left gives the command—
**NO ... SQUADRON
ADVANCE/RETIRE IN COLUMN OF ROUTE FROM THE RIGHT/LEFT
RIGHT/LEFT – TURN**
 - (3) The squadron turns right/left and is marches off as in squadron drill.
 - (4) Successive PCDRs act similarly and march to the point where the leading/rear squadron wheeled, before carrying out their wheel.
 - (5) Orders are given so that squadrons gain their correct column of route distance.
 - (6) A wing in line of squadrons in close column of flights will normally—
 - (a) advance from the right led by the leading flight of No.1 Squadron; and
 - (b) retire from the left led by the rear flight of the squadron on the left.
 - (7) A wing may, however, be marched off in any order of squadrons designated by the wing commander.

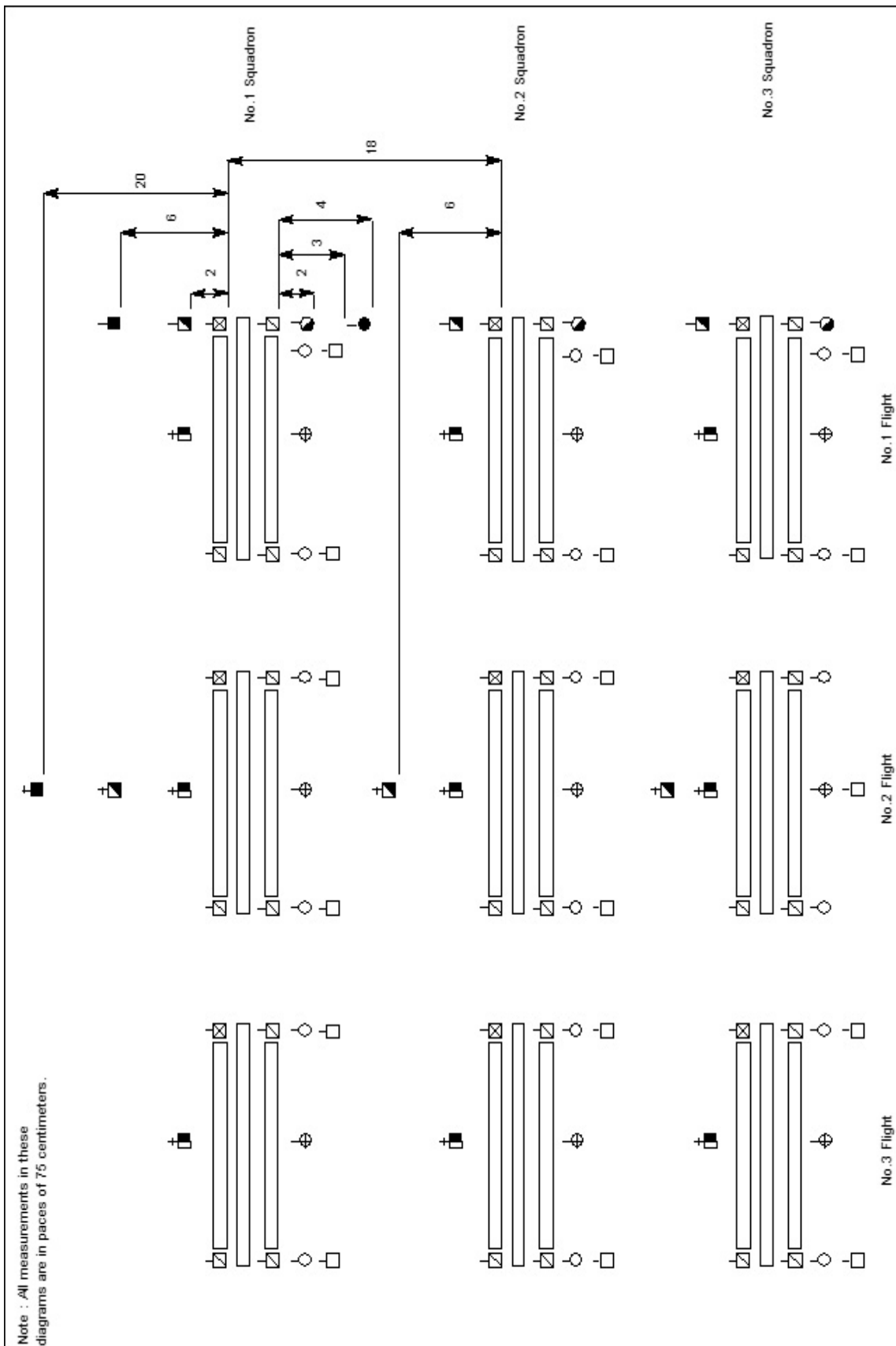

Figure 2-5-1 Wing in Close Column of Squadrons

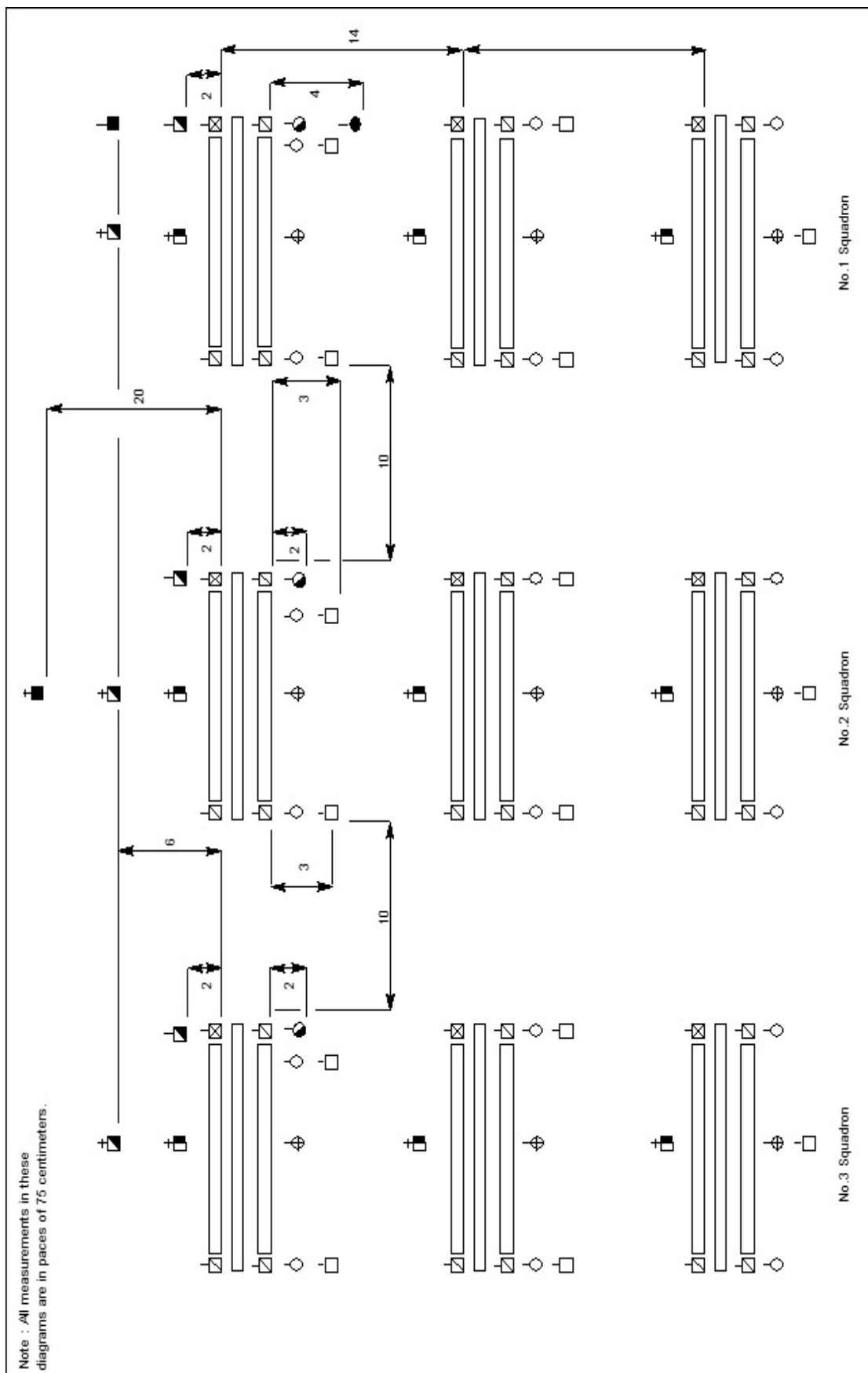

Figure 2-5-2 Wing in Line of Squadrons in Close Column of Flights

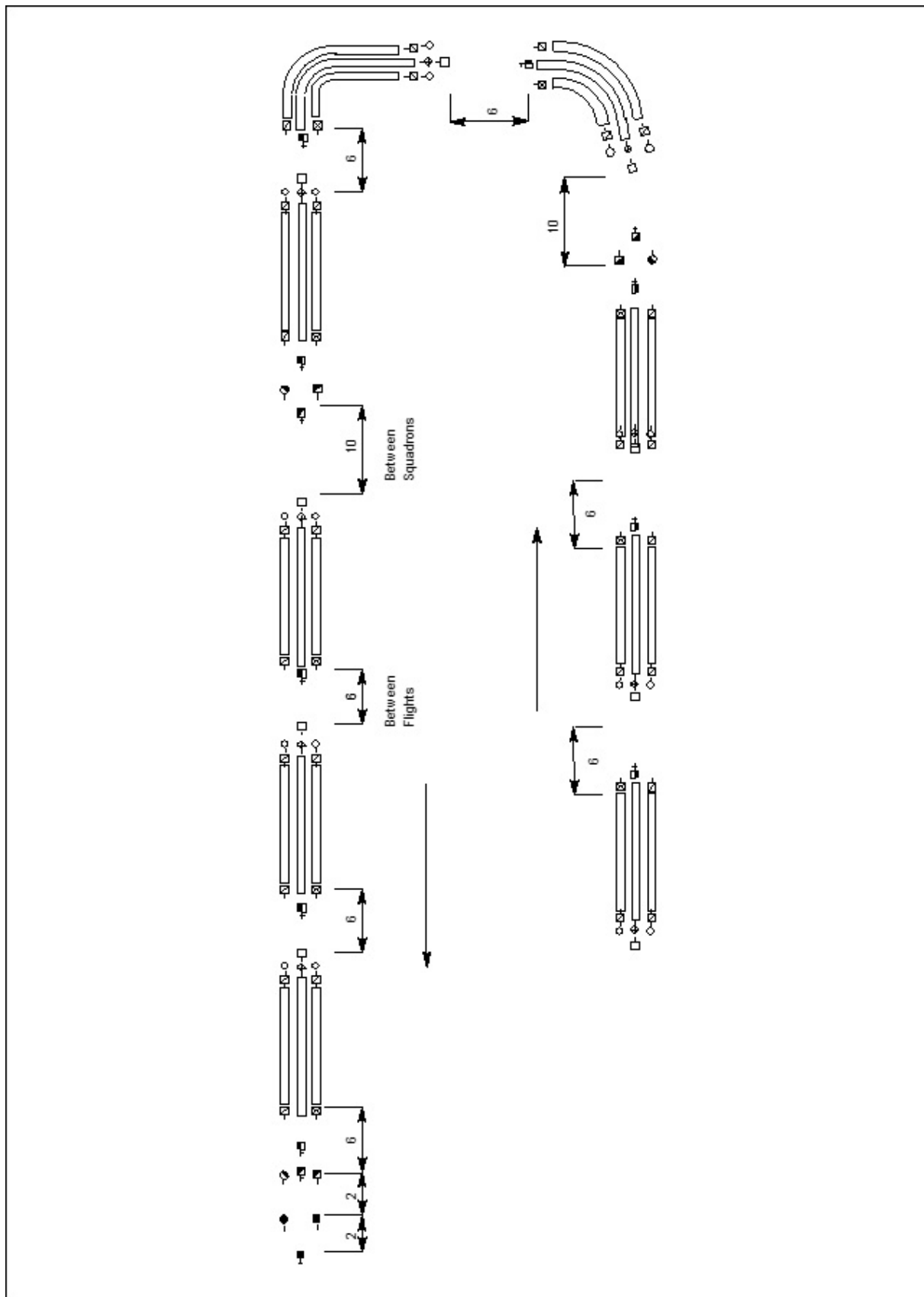

Figure 2-5-3 Wing in Column of Route

Chapter 6 – Marching Discipline

2.6.1 Object of march discipline

- a. The foundation of good march discipline depends on—
 - (1) keeping step;
 - (2) maintaining exact covering;
 - (3) maintaining dressing; and
 - (4) maintaining the prescribed distance and intervals from person to person.
- b. These essential points are to be insisted upon at all times.

2.6.2 Marching in column of route

- a. Units moving in column of route (which is the normal formation for marching) are to march well into the side of the road so as not to impede traffic.
- b. The side of the road selected depends on the rule of the country.
- c. The directing flank is to be in accordance with the rule of the road
- d. During halts, other ranks (ORs) are to fall out on the side of the road on which they are marching.
- e. The off-side of the road is to be kept clear for the passage of other traffic.
- f. On long marches it is desirable to change over the ORs on the inner and outer flanks of each section of threes.
- g. In tropical climates or under dusty conditions, and when it is desirable to avoid being seen from the air, a column is to be opened out on each side of the road, leaving the centre of the road clear.

2.6.3 Distances

- a. The following distances are normally to be maintained between units and formations in column of route—
 - (1) Between flights — 6 paces (approximately 5 metres).
 - (2) Between squadrons — 10 paces (approximately 8 metres).
 - (3) Between wings — 24 paces (approximately 20 metres).
- b. An increase of intervals and distances may be ordered.

2.6.4 Signals

The signals to march to attention and to march at ease are to be given by whistle or verbal order, which is to be passed down the column. These signals are to be arranged by the column commander.

2.6.5 Rules of marching

- a. The following rules are to be observed by units on the march—
 - (1) **When leaving/approaching places of assembly and when paying compliments.**
Units are to march at attention.
 - (2) **Column of route.** Sections of threes are to be kept—
 - (a) dressed;
 - (b) closed up; and
 - (c) covered off.
 - (3) No officer, warrant officer (W/O) or non-commissioned officer (NCO) is to march outside the column.
- b. **Head and rear of a column**
 - (1) An officer, W/O or NCO is to march at the head and in rear of each flight and/or squadron.
 - (2) Look-out personnel are to march at suitable distances in front and rear to warn motor vehicles either by hand signals or by the display of a suitable notice.
 - (3) At night the look-out personnel are to carry lights and wear Hi-Viz vests. The front light is to be white, the rear light is to be red.
- c. **Halts**
 - (1) Halts are to be made for ten minutes after every hour of marching, irrespective of the time of the start or the nearness of the end of the march.
 - (2) During halts, crossroads and road junctions are to be left clear for traffic.
 - (3) Every OR is to—
 - (a) take off their equipment during each clock hour halt; and
 - (b) put it on again one minute before starting.
 - (4) In suitable conditions the personnel are to—
 - (a) relax during halts; and
 - (b) if possible, they are to raise their feet to promote blood circulation.

d. Moving off and halting

- (1) A wing is to move off and halt by squadrons when the signal is given.
- (2) The wing is to be warned by signal or whistle one minute before each halt.
- (3) Units are to march to attention when the warning signal to halt is given.
- (4) ORs are to wait for orders from the flight commanders (FLTCDRs) before falling out after the order to halt has been given.
- (5) ORs are to fall in, in column of route, and stand at ease when the warning signal to start is given.
- (6) On the command—

QUICK – MARCH

- ORs are to come to attention and march off, after which they are to march at ease without any further order being given.

e. Rate of marching

- (1) The rate of marching is to be about 30 m per minute (ie about 1.6 km in 18 minutes, which is approximately or 4.8 km/hr, including halts).
- (2) Personnel are not to be called upon to exceed this rate in normal circumstances.
- (3) The pace is to be regulated from the head of the column to avoid exhausting the personnel in the rear.
- (4) ORs are not to be marched at double time while on the march.
- (5) If the normal rate of marching is not maintained, such that the required distance is not being covered in the required time, attempt is to be made to increase the rate of marching gradually so as to attain the required distance.
- (6) If this measure fails, word is to be sent to the head of the column to march at a slower rate.

PART 3 – CEREMONIAL DRILL

Note: The ceremonial drills in this part are for guidance purposes. They may be adjusted to fit different locations and to serve the specific requirements of different ceremonial events.

Contents

| | |
|---|-------------|
| Chapter 1 – Ceremonial Drill | 3-1 |
| 3.1.1 Object of ceremonial drill | 3-1 |
| 3.1.2 Review parade ground | 3-1 |
| 3.1.3 Ceremonial of review – general | 3-1 |
| 3.1.4 Flight parades | 3-2 |
| 3.1.5 Squadron parades | 3-2 |
| 3.1.6 Wing parades | 3-2 |
| 3.1.7 Flights | 3-3 |
| 3.1.8 Squadrons | 3-3 |
| 3.1.9 Wings | 3-4 |
| 3.1.10 General | 3-4 |
| 3.1.11 Dressing | 3-4 |
| 3.1.12 Saluting | 3-4 |
| 3.1.13 Compliments | 3-5 |
| 3.1.14 Rules for spectators at ceremonial parades | 3-5 |
| Table 3-1-1 Rules for Spectators at Ceremonial Parades | 3-5 |
| Figure 3-1-1 Review Parade Ground | 3-6 |
| Chapter 2 – Review of a Flight | 3-7 |
| 3.2.1 Forming-up for ceremonial | 3-7 |
| 3.2.2 Ceremonial of the review | 3-7 |
| Table 3-2-1 Ceremonial Procedure for Review of a Flight | 3-7 |
| Chapter 3 – Review of a Squadron | 3-11 |
| 3.3.1 Forming up for ceremonial | 3-11 |
| 3.3.2 Ceremonial of the squadron review | 3-11 |
| Table 3-3-1 Procedure for Ceremonial Review of a Squadron | 3-11 |
| 3.3.3 Squadron Standard party dilemmas | 3-16 |

| | |
|--|-------------|
| Chapter 4 – Review of a Wing | 3-18 |
| 3.4.1 General. | 3-18 |
| 3.4.2 Forming-up for ceremonial | 3-18 |
| 3.4.3 Ceremonial of the review. | 3-18 |
| Table 3-4-1 Procedure for Ceremonial Review of a Wing | 3-18 |
| 3.4.4 Alternative procedure for the ceremonial review of a wing | 3-22 |
| Table 3-4-2 Alternative Procedure for Ceremonial Review of a Wing | 3-22 |
| Chapter 5 – Service and State Funerals | 3-24 |
| Section 1 – Service funerals | 3-24 |
| 3.5.1 General. | 3-24 |
| 3.5.2 The funeral party. | 3-24 |
| 3.5.3 Order of march | 3-25 |
| 3.5.4 The funeral procession | 3-25 |
| 3.5.5 Bearer drill. | 3-26 |
| 3.5.6 The funeral ceremony. | 3-27 |
| Table 3-5-1 Service Funeral Ceremony Procedures and Commands | 3-27 |
| 3.5.7 Arrival at the cemetery. | 3-28 |
| Table 3-5-2 Procedure and Commands for Arrival of a Service Funeral Cortege at the Cemetery | 3-28 |
| 3.5.8 Service at the cemetery | 3-29 |
| Section 2 – State funerals. | 3-29 |
| 3.5.9 Introduction. | 3-29 |
| 3.5.10 Taking up position on the route. | 3-29 |
| 3.5.11 Procession | 3-30 |
| 3.5.12 Arrival at the cemetery. | 3-30 |
| Table 3-5-3 Procedure for a funeral procession | 3-31 |
| 3.5.13 Procession to graveside | 3-32 |
| 3.5.14 At the graveside. | 3-33 |
| Table 3-5-4 Graveside Procedure at Cemetery. | 3-33 |
| 3.5.15 Forming up after the ceremony. | 3-34 |

| | |
|--|-------------|
| Section 3 – Alternative funeral procedure | 3-34 |
| 3.5.16 General | 3-34 |
| 3.5.17 Administrative considerations | 3-35 |
| Section 4 – Memorial service | 3-36 |
| 3.5.18 Coffin | 3-36 |
| 3.5.19 Accoutrements on the coffin | 3-37 |
| 3.5.20 Other preparations | 3-37 |
| 3.5.21 General | 3-37 |
| 3.5.22 Procedure following memorial service | 3-38 |
| Section 5 – Procession to and arrival at the cemetery | 3-39 |
| 3.5.23 Order of procession to the cemetery | 3-39 |
| 3.5.24 Arrival at the cemetery | 3-40 |
| Section 6 – Interment service | 3-41 |
| 3.5.25 Procedure for an interment service | 3-41 |
| 3.5.26 After interment | 3-42 |
| Section 7 – Māori funeral procedure | 3-42 |
| 3.5.27 Cultural significance | 3-42 |
| Chapter 6 – Cenotaph Drill | 3-43 |
| 3.6.1 Cenotaph drill | 3-43 |
| Chapter 7 – Guards of Honour | 3-44 |
| 3.7.1 General | 3-44 |
| 3.7.2 Formation of the guard | 3-44 |
| 3.7.3 Queen’s Colour/Squadron Standard drill and procedure | 3-44 |
| 3.7.4 Mounting a guard of honour | 3-44 |
| Table 3-7-1 Falling in of Officers for a Guard of Honour and arrival of VIP(s) | 3-45 |
| 3.7.5 Guards of honour at parliament | 3-48 |
| 3.7.6 VIP visit to a base | 3-48 |
| Figure 3-7-1 Formations for Guards of Honour | 3-50 |
| Figure 3-7-2 Royal Guard of Honour in Column of Route with and without the Queen’s Colour | 3-51 |

UNCLASSIFIED

NZAP 2.4 Manual of Ceremonial and Drill
 Part 3 – Ceremonial Drill
 Contents

Version 6.00
 13 June 2023

| | | |
|---|---|-------------|
| Figure 3-7-3 | Layout of Parliament Grounds for Guards of Honour. | 3-52 |
| Figure 3-7-4 | Layout for Ceremony of Welcome for a VIP/VVIP. | 3-53 |
| Chapter 8 – Royal Guards at Government House | | 3-54 |
| 3.8.1 | Royal Guards at Government House | 3-54 |
| Chapter 9 – Quarter Guards | | 3-55 |
| 3.9.1 | Mounting a quarter guard | 3-55 |
| 3.9.2 | Quarter guard composition | 3-55 |
| 3.9.3 | Arrivals and departures by vehicle at the main gate | 3-55 |
| Figure 3-9-1 | Layout for a Quarter Guard at the Main Gate. | 3-56 |
| 3.9.4 | Procedure for aircraft arrivals | 3-56 |
| 3.9.5 | Procedure for aircraft departures | 3-56 |
| Table 3-9-1 | Format for Quarter Guard at Main Gate. | 3-57 |
| Figure 3-9-2 | Layouts for a Large Aircraft Arrival. | 3-58 |
| Figure 3-9-3 | Layout for a Small Aircraft Arrival. | 3-58 |
| Figure 3-9-4 | Layouts for a Helicopter Arrival | 3-59 |
| Figure 3-9-5 | Layouts for Large Aircraft Departures | 3-59 |
| Figure 3-9-6 | Layout for Small Aircraft Departures | 3-60 |
| Figure 3-9-7 | Layouts for Helicopter Departures. | 3-60 |
| Table 3-9-2 | Format for Quarter Guard at Aircraft Arrivals and Departures | 3-61 |
| 3.9.6 | Guest arrival at the Tūrangawaewae. | 3-62 |
| Table 3-9-3 | Procedure for arrival of VIPs at the Tūrangawaewae. | 3-63 |
| Figure 3-9-8 | Layout for Tūrangawaewae visit. | 3-64 |
| Chapter 10 – Route Lining | | 3-65 |
| 3.10.1 | Preparation | 3-65 |
| 3.10.2 | Positions. | 3-65 |
| 3.10.3 | Taking up positions on the route | 3-65 |
| 3.10.4 | Arrival of the procession. | 3-66 |
| 3.10.5 | Reforming when the procession has passed. | 3-67 |

| | |
|--|-------------|
| Chapter 11 – Graduation Parade | 3-68 |
| 3.11.1 Preliminary | 3-68 |
| Figure 3-11-1 Graduation Parade Identifiers | 3-68 |
| Section 1 – Outdoor parade procedure | 3-69 |
| 3.11.2 Squadron fall-in | 3-69 |
| 3.11.3 Parade form up | 3-69 |
| Table 3-11-1 Procedure for Form Up of a Graduation Parade | 3-69 |
| 3.11.4 Arrival of the reviewing officer/VIP(s) | 3-71 |
| Table 3-11-2 Arrival of the Reviewing Officer/VIP(s) at a Graduation Parade | 3-71 |
| 3.11.5 March on the Squadron Standard | 3-72 |
| Table 3-11-3 March on of Squadron Standard for Graduation Parade | 3-72 |
| 3.11.6 Presentation of wings and awards | 3-72 |
| Table 3-11-4 Presentation of Wings and Awards at a Graduation Parade ... | 3-72 |
| 3.11.7 Flypast | 3-74 |
| Table 3-11-5 Procedure for the Flypast at a Graduation Parade | 3-74 |
| 3.11.8 Parade dispersal | 3-74 |
| Table 3-11-6 Procedure for the Dispersal of a Graduation Parade | 3-74 |
| Section 2 – Wet weather alternative | 3-76 |
| 3.11.9 Parade format | 3-76 |
| 3.11.10 Parade form up | 3-76 |
| 3.11.11 March on the Squadron Standard | 3-76 |
| 3.11.12 Arrival of the reviewing officer/VIP | 3-76 |
| Figure 3-11-2 Graduation Parade Outdoor Format | 3-77 |
| Table 3-11-7 Forming up an Indoor Graduation Parade | 3-78 |
| 3.11.13 Presentation of wings and awards | 3-78 |
| 3.11.14 Flypast | 3-78 |
| 3.11.15 Parade dispersal | 3-79 |
| Figure 3-11-3 Graduation Parade Wet Weather Format | 3-80 |

| | |
|--|-------------|
| Chapter 12 – Change of Command Parade with the Sovereign’s Colour | 3-81 |
| Section 1 – Outdoor parade procedure | 3-81 |
| 3.12.1 Parade format | 3-81 |
| 3.12.2 Parade form up | 3-81 |
| Table 3-12-1 Form Up of an Outdoor Change of Command Parade with Queen’s Colour | 3-82 |
| 3.12.3 Handover of the Queen’s Colour | 3-85 |
| Table 3-12-2 Handover of the Queen’s Colour | 3-85 |
| 3.12.4 Parading the Queens Colour | 3-86 |
| Table 3-12-3 Procedure for Parading the Queen’s Colour | 3-86 |
| 3.12.5 Advance in review order | 3-86 |
| Table 3-12-4 Advance in Review Order During Parading the Queen’s Colour | 3-86 |
| 3.12.6 VIP departures | 3-87 |
| Table 3-12-5 Departure of VIPs from Parading the Queen’s Colour | 3-87 |
| 3.12.7 March off the Queens Colour and Squadron Standards | 3-88 |
| Table 3-12-6 Procedure for Marching off the Queen’s Colour | 3-88 |
| 3.12.8 Escort squadron march off/dismiss | 3-88 |
| Table 3-12-7 Procedure for March off/Dismiss of Escort Squadron | 3-88 |
| Section 2 – Indoor parade procedure | 3-89 |
| 3.12.9 Parade format | 3-89 |
| 3.12.10 Parade procedures | 3-89 |

Chapter 1 – Ceremonial Drill

3.1.1 Object of ceremonial drill

- a. The object of ceremonial drill is to enable a reviewing officer to judge the standard of drill and the steadiness of the units on parade.
- b. The standard of ceremonial drill indicates to a great degree the efficiency of a unit's discipline.
- c. The ceremonial drill for the review of a flight, squadron or wing, is dealt with in this chapter.

3.1.2 Review parade ground

- a. The parade ground on which the unit receives and marches past the reviewing officer is normally to be a rectangle of 160 paces in length and 80 paces in width, or such other size as is dictated by the parade formation and the space available.
- b. The four corners, numbered 1, 2, 3 and 4 are to be so positioned as to allow all drill movements to be carried out within the limits of the parade ground proper. (Refer to Figure [3-1-1](#).)
- c. The area is to be marked out with continuous or interrupted lines. Where this is not possible, for example on a flight line, the four corners are to be determined by high visibility cones.
- d. The point termed the 'saluting point' is to be marked in the centre of the side between Points 2 and 3 and set five paces back from the line joining these two points. Two points, A and B, are to be marked 10 paces to the left and right respectively of the saluting point in line with Points 2 and 3. The distance of 20 paces between points A and B is termed the 'saluting base'. (Refer to Figure [3-1-1](#).) The saluting point is best delineated by the positioning of cones complete with pennants, if available.
- e. A point is to be marked on the side of the review parade ground opposite the saluting point and between Points 1 and 4 so as to mark the position of the centre of that line. The whole line between Points 1 and 4 is termed the 'receiving base'.
- f. Points A, B, 1, 2, 3 and 4, are to be marked by the unit commander's flag on poles approximately 2.5 m high. The saluting point is to be marked by the Royal New Zealand Air Force (RNZAF) Ensign 180 cm x 90 cm on a pole approximately 3.5 m high.

3.1.3 Ceremonial of review – general

- a. The ceremonial of the review of a flight, squadron or wing consists of—
 - (1) the reception of the reviewing officer;
 - (2) the inspection by the reviewing officer;

- (3) the march past the reviewing officer; and
 - (4) the advance in review order.
- b. Paragraphs 3.1.4, 3.1.5 and 3.1.6 outline which drill formations are to be used.

3.1.4 Flight parades

When a flight is to be paraded independently, it is to be formed up in line and is to carry out the ceremonial in that formation.

3.1.5 Squadron parades

- a. When a squadron is to be paraded independently, it is to be formed up on the receiving base in close column of flights.
- b. The squadron is to march past by flights independently, after which it is to march past in close column of flights.
- c. The advance in review order is to be carried out in close column of flights.

3.1.6 Wing parades

- a. When a wing is to be paraded, it is to be formed up on the receiving base in line of squadrons in close column of flights.
- b. The wing is to march past by flights and then by squadrons in close column of flights.
- c. The advance in review order is to be carried out in line of squadrons on close column of flights.
- d. Normally squadrons are to march past by flights at column distance but, so that two flights shall not be on the saluting base at the same time, a minimum distance of 25 paces is to be maintained between flights when marching past. The distance between squadrons marching past independently is to be 60 paces.
- e. When the space for the ceremonial is limited, the march past may be carried out in column of route.
- f. Units are to be in open order during the reception and inspection by the reviewing officer.
- g. Officers are to take up position in review order for—
 - (1) the reception of the reviewing officer; and
 - (2) the advance in review order.
- h. During the advance in review order, the band is to play the 'Advance in Review Order' and the units are to be halted when about 30 paces from the reviewing officer. If necessary, the distance may be reduced.

- i. The flight, squadron or wing is to be drawn up on the receiving base in the drill formation ordered, with its centre opposite the saluting point.
- j. The band is to be formed up to the rear of the centre of the flight, squadron or wing, at 10 paces distance.
- k. The following movements are to be carried out when parading.

3.1.7 Flights

A flight, when parading independently, after having received the reviewing officer and having been inspected, is to—

- (1) Wheel round Point 1, turn into line on the march as its right guide reaches Point 2, and march past.
- (2) The band is to remain in its position and play a quick march while the flight is moving from the receiving base.
- (3) As the flight turns into line at Point 2, the bandmaster is to cause the band to move forward and halt with its front rank in line with Points 1 and 4, where it is to continue to play during the march past.
- (4) The flight is to—
 - (a) march past;
 - (b) turn right as it carries out two left wheels; and
 - (c) move to Point 4 wheeling around that point and form up in its original position on the receiving base with its centre opposite the saluting point.
- (1) The band is to counter march to its original position to the rear of the receiving base.
- (2) The flight is then to advance in review order, the band advancing at the same time playing the 'Advance in Review Order'.

3.1.8 Squadrons

- a. A squadron, after having received the reviewing officer and having been inspected, is to wheel round Point 1 in column of threes and advance in column facing left. Each flight is to be turned into line on the march as its leading guide reaches Point 2, and march past independently.
- b. The squadron, after marching past by flights in column is to—
 - (1) turn right by flights at Point 3;
 - (2) carry out two left wheels;
 - (3) wheel around Point 4; and

UNCLASSIFIED

NZAP 2.4 Manual of Ceremonial and Drill
Part 3 – Ceremonial Drill
Chapter 1 – Ceremonial Drill

Version 6.00
13 June 2023

- (4) be halted in its original formation on the receiving base for a flight parading independently.
- c. The squadron is to advance in review order, the band advancing at the same time playing the 'Advance in Review Order'.

3.1.9 Wings

A wing is to act in a similar manner independently by squadrons. The band is to act as detailed for a flight parading independently.

3.1.10 General

- a. When a flight, squadron or wing, is to march past in column of route, the band is to be 10 paces in front of the commander and is to change direction when ordered.
- b. The term 'Band' is used to include drums and trumpets.
- c. The ceremonial of the review is to be carried out, as detailed, by any unit or formation organised into flights or squadrons.
- d. When an officer of superior rank to that of the formation or unit commander is on the parade, they are to be 10 paces in front of that commander.

3.1.11 Dressing

- a. In ceremonial drill the dressing is to be carried out as laid down for flight, squadron and wing drill. Other Ranks (ORs) are to take up their dressing rapidly and correctly.
- b. The guides and markers are to be responsible for maintaining the correct direction, covering and distance, when marching. They are not to turn their heads towards the reviewing officer when the 'EYES RIGHT/LEFT' command is given during the march past.

3.1.12 Saluting

- a. When the reviewing officer is being received, and for the salute at the end of the 'Advance in Review Order', all officers are to salute with their swords, except when otherwise indicated.
- b. When a wing marches past by squadrons in close column of flights, the wing commander and parade commanders (PCDRs) only are to salute.
- c. In column of route, compliments are to be paid by flights. The wing commander, PCDRs, flight commanders (FLTCDRs), wing adjutant (WADJ), squadron adjutants (SADJs), and wing warrant officer (WWO) and squadron warrant officers (SWOs) are to salute.
- d. When a squadron marches past by flights, compliments are to be paid by flights. The PCDR, FLTCDRs and SADJ are to salute.

UNCLASSIFIED

NZAP 2.4 Manual of Ceremonial and Drill
 Part 3 – Ceremonial Drill
 Chapter 1 – Ceremonial Drill

Version 6.00
 13 June 2023

- e. When a squadron marches past in close column of flights, the commanding officer only is to salute.
- f. Non-commissioned officers (NCOs) acting as guides and markers are to carry rifles with bayonets fitted, irrespective of their rank. W/Os and NCOs in command of flights are to salute when marching past.

3.1.13 Compliments

The honours and salutes to be given by RNZAF personnel on parade are contained in [AFGO](#) *Air Force General Orders*.

3.1.14 Rules for spectators at ceremonial parades

The general rules for spectators at ceremonial parades are contained in [Table 3-1-1](#).

Table 3-1-1 Rules for Spectators at Ceremonial Parades

| Parade action | Spectator response |
|---|--|
| Marching on QC/SqnSs | When uncased QC/SqnSs pass in front, spectators stand and either salute or uncover their heads. |
| Arrival of the reviewing officer | For a general salute, spectators stand but do not salute. For a royal salute they stand and either salute or uncover their heads. |
| Reviewing officer returns from inspection | Spectators remain seated. |
| Presentation of QC/SqnS | When the QC/SqnS bearer joins the parade with the QC/SqnS, spectators stand and either salute or uncover their heads. |
| March past with QC/SqnS | Spectators stand and either salute or uncover their heads as the QC/SqnS passes directly in front of them. |
| March past without a QC/SqnS | Spectators remain seated. |
| Advance in review order | For a general salute spectators stand. For a royal salute spectators stand and either salute or uncover their heads. |
| Marching off a QC/SqnS | When an uncased QC/SqnS passes in front of them, spectators stand and either salute or uncover their heads. |
| Prayers on parade | Spectators remain seated during prayers. |
| Breaking of a sovereign's personal flag for New Zealand at the sovereign's birthday parades | Spectators are to stand and face flag for the playing of British National Anthem. Service-persons in uniform are to salute. |

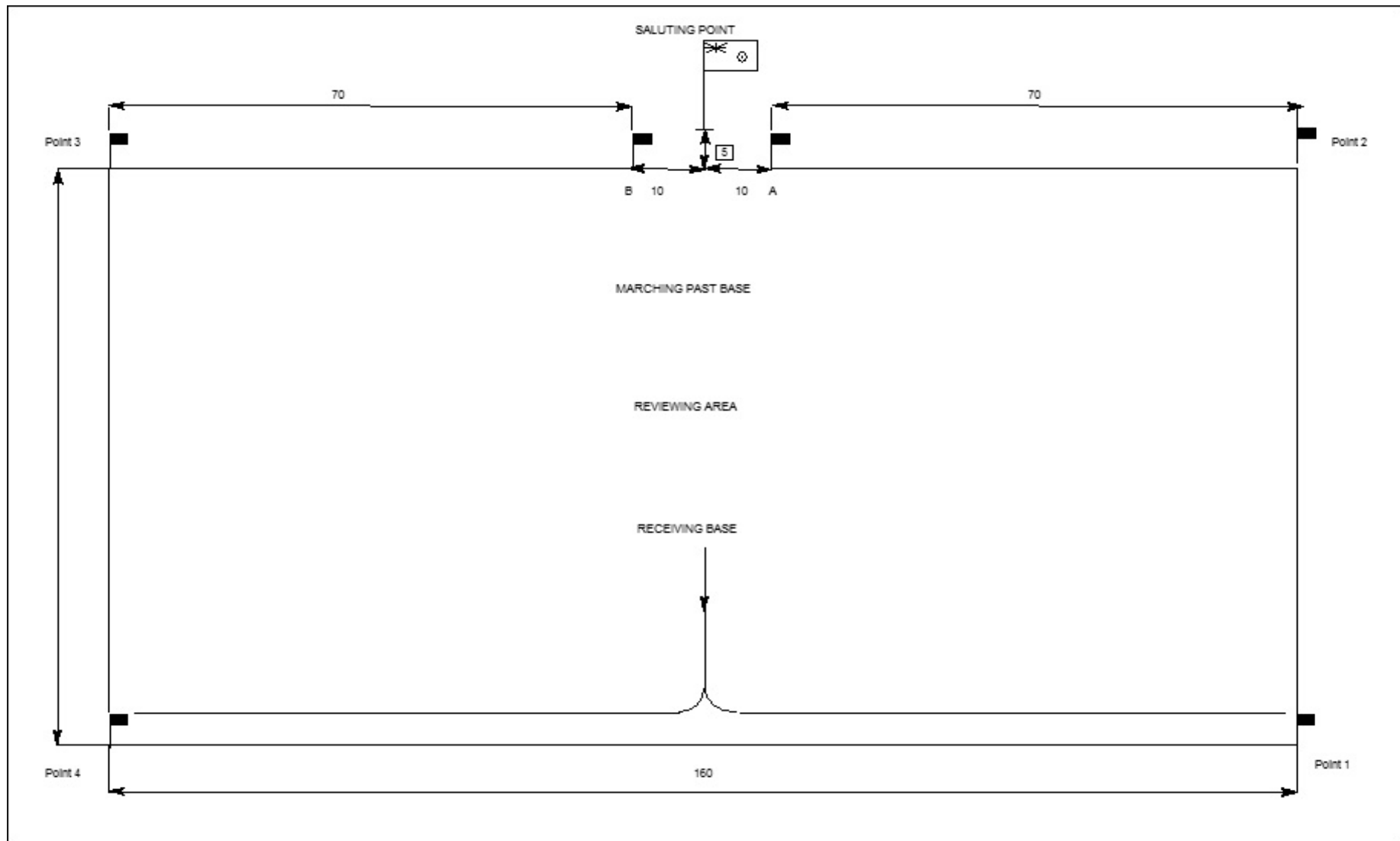

Figure 3-1-1 Review Parade Ground

Chapter 2 – Review of a Flight

3.2.1 Forming-up for ceremonial

- a. The flight is to be formed up at an identified location and is to be sized by the flight sergeant (F/S) (with rifles with bayonets fixed, if required) before being handed over to the flight commander (FLTCDR). In normal circumstances it is reasonable to assume that the flight is sized during lead in rehearsals.
- b. When the FLTCDR has inspected the flight, they order officers to draw swords, after which they march the flight to its position on the receiving base, where it is to be drawn up facing the saluting point. (Refer to Figure [3-1-1](#)).

3.2.2 Ceremonial of the review

The procedure for ceremonial review of a flight is shown in Table [3-2-1](#).

Table 3-2-1 Ceremonial Procedure for Review of a Flight

| Serial | Commander | Command | Action |
|--------|--|---|---|
| 1 | FLTCDR | OFFICERS TAKE POST IN REVIEW ORDER LEFT TURN QUICK – MARCH | <ul style="list-style-type: none"> – The supernumerary officers— – turn to their left; – move around the flank of the flight; and – take up position at equal intervals along its frontage, two paces in front of the front rank. – The FLTCDR takes up a central position two paces in front of the supernumerary officers. |
| 2 | When all officers are in position— FLTCDR | OFFICERS LEFT – TURN FLIGHT IN OPEN ORDER – RIGHT DRESS EYES – FRONT STAND AT – EASE | |
| 3 | When the reviewing officer has reached a point approximately 50 metres away from the parade— FLTCDR | FLIGHT FLIGHT – SHUN | |
| 4 | When the reviewing officer is in position in front of the saluting point— FLTCDR | GENERAL SALUTE PRESENT – ARMS | |

UNCLASSIFIED

| Table 3-2-1 Ceremonial Procedure for Review of a Flight (cont.) | | | |
|--|---|---|--|
| Serial | Commander | Command | Action |
| 4b | If the flight is being reviewed by a royal/vice-regal/presidential personage— | | |
| | FLTCDR | ROYAL/VICE-REGAL/ PRESIDENTIAL SALUTE PRESENT – ARMS | |
| 5 | Bandmaster | | – The band plays the appropriate salute. |
| 6 | FLTCDR | SHOULDER – ARMS | <ul style="list-style-type: none"> – The FLTCDR reports to the reviewing officer that the flight is ready for inspection. – The reviewing officer inspects the flight, accompanied by the FLTCDR. – At the end of the inspection the FLTCDR requests permission from the reviewing officer to carry out the march past. |
| 7 | FLTCDR | IN CLOSE ORDER RIGHT – DRESS EYES – FRONT MOVE TO THE RIGHT IN COLUMN OF THREES RIGHT – TURN BY THE LEFT QUICK – MARCH | |
| 8 | When the right guide reaches Point 1— | | |
| | FLTCDR | CHANGE DIRECTION LEFT LEFT WHEEL | |
| 9 | When the guide reaches Point 2— | | |
| | FLTCDR | FLIGHT WILL ADVANCE LEFT – TURN BY THE RIGHT | |
| 10 | When the FLTCDR reaches Point A— | | |
| | FLTCDR | FLIGHT EYES – RIGHT | |
| 11 | When the F/S is abreast of Point B— | | |
| | FLTCDR | FLIGHT EYES – FRONT | |
| 12 | When the marker reaches Point 3— | | |
| | FLTCDR | FLIGHT WILL MOVE TO THE RIGHT IN THREES RIGHT – TURN | – The FLTCDR orders three left wheels to bring the flight to its original position on the receiving base. |

UNCLASSIFIED

UNCLASSIFIED

| Table 3-2-1 Ceremonial Procedure for Review of a Flight (cont.) | | | |
|--|---|---|---|
| Serial | Commander | Command | Action |
| 13 | As the flight approaches its original position— | | |
| | FLTCDR | FLIGHT – HALT FLIGHT WILL ADVANCE LEFT – TURN RIGHT – DRESS EYES – FRONT FLIGHT WILL ADVANCE IN REVIEW ORDER BY THE CENTRE QUICK – MARCH GENERAL SALUTE PRESENT – ARMS SHOULDER – ARMS | <ul style="list-style-type: none"> – The FLTCDR reports to the reviewing officer, salutes and invites them to address the parade. – After saluting, the FLTCDR— <ul style="list-style-type: none"> – requests permission to carry on; – turns right; – moves to a designated position to the left of the dais; – halts; and – turns to face the parade. |
| 14 | Reviewing officer address, presentations (if appropriate) | | |
| | FLTCDR | FLIGHT STAND AT – EASE | <ul style="list-style-type: none"> – The flight stands at ease. – The FLTCDR also stands at ease. |
| 15 | When addresses, presentations etc are completed— | | |
| | <ul style="list-style-type: none"> – The FLTCDR— <ul style="list-style-type: none"> – calls the flight to attention; – reports to the reviewing officer; – salutes and requests permission for prayers to be said and to carry on; – salutes again, – turns right; – returns to their position in front of the flight; and – stands the flight at ease. | | |
| 16 | Prayers | | |
| | <ul style="list-style-type: none"> – The FLTCDR turns about and requests— ‘PADRE/CHAPLAIN – PRAYERS PLEASE’ – The FLTCDR salutes the padre/chaplain, only if the padre/chaplain is of higher rank. – The padre/chaplain returns the salute. – The FLTCDR stands at ease. – On completion of prayers the FLTCDR— <ul style="list-style-type: none"> – comes to attention; – salutes; and – thanks the padre/chaplain. | | |
| 17 | FLTCDR | FLIGHT FLIGHT – SHUN | |

UNCLASSIFIED

UNCLASSIFIED

NZAP 2.4 Manual of Ceremonial and Drill
 Part 3 – Ceremonial Drill
 Chapter 2 – Review of a Flight

Version 6.00
 13 June 2023

| Table 3-2-1 Ceremonial Procedure for Review of a Flight (cont.) | | | |
|--|--|--|---------------|
| Serial | Commander | Command | Action |
| 18 | Departure of VIPs If a car is present, the general salute given as the car moves away from the dais, otherwise— | | |
| | FLTCDR | MOVE TO THE RIGHT IN COLUMN OF ROUTE RIGHT – TURN | |
| 19 | Marching off, if— <ul style="list-style-type: none"> – the reviewing officer remains on the dais, the flight marches past in column of route and pays compliments before it marches off; or – the reviewing officer is not present, the flight marches off. | | |
| 20 | – The flight is dismissed from its designated assembly area. | | |

UNCLASSIFIED

Chapter 3 – Review of a Squadron

3.3.1 Forming up for ceremonial

- a. The squadron is to be formed up at a predetermined assembly area where it is inspected. Flights should be sized during lead in rehearsals. When rifles with bayonets are ordered as part of the ceremonial, the bayonets are to be fitted at a predetermined point away from the parade ground.
- b. After the parade commander (PCDR) has inspected the squadron, they are to order the officers to draw swords.
- c. The squadron is then marched to its position on its marker on the receiving base, where it is to be drawn up as a squadron in line of flights facing the saluting point.
- d. If the squadron are parading the Squadron Standard (SqnS), it is to be marched on.
- e. In an abbreviated format, an SqnS may be marched on before moving to the parade ground so that the squadron marches on with its SqnS in place. This is not normal, but an acceptable departure when circumstances dictate eg restricted space.
- f. The following procedure describes the commonly accepted flow of events.

3.3.2 Ceremonial of the squadron review

The procedure for the ceremonial review of a squadron is shown in Table [3-3-1](#).

| Table 3-3-1 Procedure for Ceremonial Review of a Squadron | | | |
|---|-----------|--|---|
| Serial | Commander | Command | Action |
| 1 | PCDR | OFFICERS TAKE POST IN REVIEW ORDER OUTWARDS – TURN QUICK – MARCH OFFICERS LEFT – TURN | <ul style="list-style-type: none"> – The SADJ remains in front of the marker. – FLTCDRs turn to the right and take post in front of the leading guides of their flights. – Supernumerary officers turn left, move around the flank and take up positions at equal intervals along the frontage of their flights, in line with the FLTCDR. – SADJ, No.1 Flight commander and No.1 Flight supernumerary officer take up positions at equal intervals along the frontage of No.1 Flight. |
| 2 | PCDR | IN OPEN ORDER RIGHT – DRESS EYES – FRONT STAND AT – EASE | <ul style="list-style-type: none"> – If a SqnS is carried, the PCDR takes up position 10 paces in front of the centre of the squadron. – If a SqnS is not carried, the PCDR takes up position six paces in front of the centre of the squadron. |

UNCLASSIFIED

| Table 3-3-1 Procedure for Ceremonial Review of a Squadron (cont.) | | | |
|--|--|---|---|
| Serial | Commander | Command | Action |
| 3 | PCDR | SQUADRON SQUADRON – SHUN MARCH ON THE SQUADRON STANDARD PRESENT – ARMS | The SqnSP— <ul style="list-style-type: none"> – takes up a central position six paces in front of the centre flight; and – independently makes minor adjustments to alignment once halted. |
| 4 | PCDR | SQUADRON SHOULDER – ARMS STAND AT – EASE | <ul style="list-style-type: none"> – The squadron stands at ease until the arrival of the VIP. – When the VIPs arrives— <ul style="list-style-type: none"> – The PCDR should give no other acknowledgement than to come to attention and give the short salute with the sword as appropriate to those VIPs arriving in cars. – Those accorded a salute will normally be determined beforehand and protocols according to the status of the assembling VIPs will be determined. – The rest of the squadron remains at ease. – When all VIPs are in place, the squadron is now ready to receive the reviewing officer. |
| 5 | When the reviewing officer reaches a predetermined point approaching the parade— | | |
| | PCDR | SQUADRON SQUADRON – SHUN | – The squadron comes to attention. |
| 6 | When the reviewing officer has taken up a position in front of the saluting point— | | |
| | PCDR | GENERAL SALUTE PRESENT – ARMS | <ul style="list-style-type: none"> – If the squadron is armed, the squadron salutes – If the squadron is unarmed, the officers salute. |
| | Bandmaster | | – The band plays the appropriate salute. |
| 6a | If the squadron is being reviewed by a royal/vice-regal/presidential personage— | | |
| | PCDR | ROYAL/VICE-REGAL/ PRESIDENTIAL SALUTE PRESENT – ARMS | |

UNCLASSIFIED

| Table 3-3-1 Procedure for Ceremonial Review of a Squadron (cont.) | | | |
|--|---|---|---|
| Serial | Commander | Command | Action |
| 7 | PCDR | SQUADRON SHOULDER – ARMS | <ul style="list-style-type: none"> – The PCDR reports to the reviewing officer. – The reviewing officer inspects the squadron. <p>Note: FLTCDRs do not accompany the reviewing officer during the inspection.</p> <ul style="list-style-type: none"> – At the end of the inspection, the PCDR is to request permission from the reviewing officer to carry on. <p>Note: If a SqnS is carried, it is to be at the 'Carry' position during the inspection, and brought down to the 'Order' position on completion of the inspection.</p> |
| 8 | PCDR | SQUADRON IN CLOSE ORDER – RIGHT DRESS EYES – FRONT SQUADRON WILL MARCH PAST BY FLIGHTS IN COLUMN AT 25 PACES DISTANCE MOVE TO THE RIGHT IN COLUMN OF THREES RIGHT – TURN | <ul style="list-style-type: none"> – The QC/SqnS party, under the orders of the QC/SqnS bearer, marches to its position between Nos.1 and 2 flights, – The QC/SqnS party performs a normal - not fixed - wheel. |
| 9 | PCDR | SQUADRON BY THE LEFT QUICK – MARCH | <ul style="list-style-type: none"> – The squadron steps off by the left. |
| 10 | As the leading guide of the leading flight reaches Point 1— | | |
| | PCDR | CHANGE DIRECTION LEFT LEFT WHEEL | Note: The SqnNSP perform a normal - not fixed - wheel. |
| 11 | As the leading flight approaches Point 2— | | |
| | PCDR | FACING LEFT ADVANCE IN COLUMN | |
| 12 | As the leading guide of each flight reaches Point 2— | | |
| | FLTCDR | NO... FLIGHT WILL ADVANCE LEFT – TURN BY THE RIGHT | |
| <p>If the parade includes an SqnS, and the march past in quick and slow time is followed, refer to paragraph 3.3.3 for how to deal with various dilemmas that may arise when an SqnS is being paraded.</p> <p>Without a SqnS party, the parade continues as follows—</p> | | | |
| 13 | As No.1 Flight approaches Point 3— | | |
| | PCDR | SQUADRON IN SUCCESSION MOVE TO THE RIGHT IN COLUMN OF THREES | |

UNCLASSIFIED

| Table 3-3-1 Procedure for Ceremonial Review of a Squadron (cont.) | | | |
|--|--|--|---|
| Serial | Commander | Command | Action |
| 14 | As each FLTCDR approaches Point 3— | | |
| | FLTCDR | NO ... FLIGHT MOVE TO THE RIGHT IN THREES RIGHT – TURN | |
| 15 | PCDR | | – The PCDR orders three left wheels to bring the squadron to its original position on the receiving base. |
| 16 | As the leading flight approaches its original position— | | |
| | PCDR | SQUADRON – HALT SQUADRON WILL ADVANCE LEFT – TURN | – The SqnSP resumes its original position. |
| 17 | When the SqnSP is in position— | | |
| | PCDR | SQUADRON RIGHT – DRESS EYES – FRONT | |
| 18 | PCDR | SQUADRON WILL ADVANCE IN REVIEW ORDER BY THE CENTRE QUICK – MARCH | |
| 19 | PCDR | GENERAL/ROYAL/VICE-REGAL/ PRESIDENTIAL SALUTE PRESENT – ARMS | |
| | Bandmaster | | – The band plays the appropriate salute. |
| 20 | PCDR | SHOULDER – ARMS | <ul style="list-style-type: none"> – Squadron shoulders arms. – PCDR— <ul style="list-style-type: none"> – reports to the reviewing officer; – salutes; and – invites them to address the parade. – After receiving the permission from the reviewing officer to carry on, the PCDR— <ul style="list-style-type: none"> – turns right; – moves to a designated position to the left of the dais; – halts; and – turns to face the parade. |
| 21 | PCDR | SQUADRON STAND AT – EASE | <ul style="list-style-type: none"> – Squadron stands at ease. – The PCDR also stands at ease. |
| 22 | Speeches and/or presentations. (Refer to Table 3.2.1 , serials 14 and 15.) | | |
| 23 | Prayers are offered by the padre/chaplain. | | |
| | Note: Saluting options are governed by the instructions for review of a flight. | | |

UNCLASSIFIED

UNCLASSIFIED

| Table 3-3-1 Procedure for Ceremonial Review of a Squadron (cont.) | | | |
|--|--|--|--|
| Serial | Commander | Command | Action |
| 24 | Departure of the reviewing officer As the reviewing officer's car approaches— | | |
| | PCDR | SQUADRON SQUADRON – SHUN | |
| 25 | As the car carrying the reviewing officer moves away from the dais— | | |
| | PCDR | GENERAL/ROYAL/VICE-REGAL/ PRESIDENTIAL SALUTE PRESENT – ARMS | |
| | Bandmaster | | – The band plays the appropriate salute. |
| 26 | PCDR | SHOULDER – ARMS | – Squadron shoulders arms. |
| 27 | When the reviewing officer has left the parade ground— | | |
| | PCDR | MARCH OFF THE SQUADRON STANDARD PRESENT – ARMS | – SqnSP, under the command of the SqnSB, marches off the parade ground. |
| 28 | When the SqnSP has marched off the parade ground— | | |
| | PCDR | SHOULDER – ARMS OFFICERS TAKE POST LEFT – TURN QUICK – MARCH | <ul style="list-style-type: none"> – The SADJ, FLTCDRs and supernumerary officers— – turn to the left; and – resume their original positions. |
| 29 | PCDR | FALL OUT THE OFFICERS OFFICERS QUICK – MARCH | <ul style="list-style-type: none"> – Officers— – march off the parade ground; – halt; – form a semi circle around the No.1 FLTCDR. – At the same time, F/Ss move to the vacated FLTCDR positions in front of their flights. |
| 30 | No.1 FLTCDR | OFFICERS WILL RETURN SWORDS RETURN – SWORDS TO YOUR DUTIES DIS – MISS | <ul style="list-style-type: none"> – Officers— – return their swords; and – dismiss. |
| 31 | PCDR | PARADE WARRANT OFFICER | – The PCDR hands over command of the parade to the PWO. |
| 32 | The PWO instructs the F/Ss to march off their flights— | | |
| | PWO | FLIGHT SERGEANTS MARCH OFF YOUR FLIGHTS | – The F/Ss march their respective flights to a designated area for dismissal. |
| <p>Note: Officers are to be in review order for the march past only if every officer on parade is carrying a sword. Where this is not possible officers are to resume normal positions before the march past.</p> | | | |

UNCLASSIFIED

3.3.3 Squadron Standard party dilemmas

- a. Parade planning must resolve various dilemmas that can occur during parades that include the parading of SqnSs.
- b. Taking the the parade steps up to Serial 13 of Table [3-3-1](#) in their literal sense, the SqnS party is advancing while stationed on the left flank of No.1 Flight. Furthermore, the SqnS party is displaced by some meters given that a normal turn on the march takes three paces but the SqnS party has to complete a pivot over eight paces. They cannot perform a left turn nor do a pivot wheel, and they cannot march on the flank. Options to resolve this dilemma are for the SqnS party to—
 - (1) take up a position by running to the front centre of No.1 Flight; or
 - (2) take up a position by running to the rear centre of No.1 Flight (neither of which are ceremonial).
- c. More prudently, the squadron should not perform this movement with an SqnS party. Instead what should happen is for the squadron to be halted and form close column of flights. In this situation, the command at Serial 13 of Table [3-3-1](#) should be replaced with—

AT THE HALT

FORM CLOSE COLUMN OF FLIGHTS

- The SqnS party performs a series of pivot wheels when No.1 Flight halts to take up a place in front centre of No.1 Flight.
- The squadron is dressed then stepped off.
- The PCDR is to lead the squadron.

- (1) As each flight commander (FLTCDR) arrives abreast of Point A they give the command—

NO... FLIGHT

EYES – FRONT

Note: No.1 Flight commander is to give their orders in time so that they, the PCDR and other officers of No.1 Flight all salute together.

- (2) When the rank of non-commissioned officers (NCOs) is abreast of Point B, the FLTCDR gives the command—

NO ... FLIGHT

EYES – FRONT

Note: The PCDR completes the salute on their own on reaching Point B.

- d. Another positional dilemma occurs when—
 - (1) with the SqnS party in position, the squadron halts, turns about, and the SqnS party reposition to the front of the squadron;
 - (2) the squadron marches past in slow time, paying compliments;

UNCLASSIFIED

NZAP 2.4 Manual of Ceremonial and Drill
Part 3 – Ceremonial Drill
Chapter 3 – Review of a Squadron

Version 6.00
13 June 2023

- (3) the squadron reforms at Point 2, turns about, commanders and SqnS party move into their positions;
- (4) the squadron marches back to the receiving base where it reforms as a squadron in line of flights; and
- (5) the SqnS party steps off with No.2 Flight and positions itself centrally so that, when arriving at the receiving base, it is central in front of the dais.

Chapter 4 – Review of a Wing

3.4.1 General

- a. Given the variations in composition of base parades (when the base as a whole is on parade), the detail for the review of a wing is to be used as a basis for such parades. The form of the parade is to conform as closely as possible to that described in this chapter, having regard to symmetry and the size of the parade ground available.
- b. When more than one Squadron Standard (Sqns) is to be paraded, they are to be marched on together. The senior Squadron Standard bearer (SqnsB) gives the command 'QUICK - MARCH'. Thereafter each Squadron Standard party (SqnsP) acts independently until in position.
- c. The wing formation should be in line of squadrons with the senior squadron on the right, such that the Sqns are positioned along the front of the parade.
- d. If the Queen's Colour (QC) is also paraded it is to be on the right.

3.4.2 Forming-up for ceremonial

- a. Squadrons are to be formed up at a designated assembly area where they are to be sized and inspected.
- b. Squadron markers are to be positioned on the receiving base by the wing warrant officer (WWO) as for a line of squadrons in close column of flights (Refer to Table [2-4-1 Squadron Parade Form Up](#)).
- c. On orders from the wing adjutant (WADJ) or the sounding of the 'Advance', squadron commanders (PCDRs) are to march their squadrons on to their markers on the review parade ground from the left flank. PCDRs' distance in front of their squadrons (six or ten paces) will depend whether or not Sqns are to be paraded.
- d. The wing commander takes up position two paces behind the WADJ.

3.4.3 Ceremonial of the review

The procedure for the ceremonial review of a wing is shown in Table [3-4-1](#).

Table 3-4-1 Procedure for Ceremonial Review of a Wing

| Serial | Commander | Command | Action |
|--------|-------------------------------------|--|--|
| 1 | When all squadrons are in position— | | |
| | WADJ | WING WING – SHUN RIGHT – DRESS EYES – FRONT | <ul style="list-style-type: none"> – The WADJ turns about and hands over to the wing commander, saying— <i>'Wing on parade Sir/Ma'am'</i> – The WADJ takes up their position in front of No.1 Squadron marker and in line with the PCDRs. |

| Table 3-4-1 Procedure for Ceremonial Review of a Wing (cont.) | | | |
|--|--|---|---|
| Serial | Commander | Command | Action |
| 2 | WGCDR | OFFICERS TAKE POST IN REVIEW ORDER OUTWARDS – TURN QUICK – MARCH | <ul style="list-style-type: none"> – PCDRs and WADJ stand fast. – The SADJ, FLTCDRs and supernumerary officers act as detailed in the review of a squadron (refer to Part 3, Chapter 3), allowing space for the SqnS party when necessary. |
| 3 | WGCDR | OFFICERS LEFT – TURN WING IN OPEN ORDER RIGHT – DRESS EYES – FRONT | <ul style="list-style-type: none"> – The wing commander takes up position 15 paces in front of the centre of the front rank of the centre squadron. – SqnSs are marched on, as detailed in the review of a squadron (refer to Part 3, Chapter 3). – The wing is now ready to receive the reviewing officer. |
| 4 | WGCDR | WING STAND AT – EASE | <ul style="list-style-type: none"> – The wing stands at ease. |
| 5 | When the reviewing officer reaches a position about 50 metres away from the parade— | | |
| | WGCDR | WING WING – SHUN | |
| 6 | When the reviewing officer has taken up their position in front of the saluting point— | | |
| | WGCDR | GENERAL SALUTE PRESENT – ARMS | <ul style="list-style-type: none"> – The wing gives the appropriate salute. <p>Note: If the wing is being reviewed by a royal/vice-regal/presidential personage, the command is to be—</p> <p>‘ROYAL/VICE-REGAL/PRESIDENTIAL SALUTE, PRESENT – ARMS’.</p> |
| | Bandmaster | | <ul style="list-style-type: none"> – The band plays the appropriate salute. |
| 7 | WGCDR | WING SHOULDER – ARMS | <ul style="list-style-type: none"> – The wing commander reports to the reviewing officer. – The reviewing officer, accompanied by the wing commander, the WADJ and the aide to the reviewing officer, inspects the wing by squadrons. <p>Note: PCDRs and FLTCDRs do not accompany the reviewing officer on the inspection.</p> <ul style="list-style-type: none"> – At the end of the inspection the wing commander requests permission from the reviewing officer to march past. |

UNCLASSIFIED

NZAP 2.4 Manual of Ceremonial and Drill
 Part 3 – Ceremonial Drill
 Chapter 4 – Review of a Wing

Version 6.00
 13 June 2023

| Table 3-4-1 Procedure for Ceremonial Review of a Wing (cont.) | | | |
|--|---|---|---|
| Serial | Commander | Command | Action |
| 8 | On resuming position— | | |
| | WGCDR | WING WING – SHUN IN CLOSE ORDER – RIGHT DRESS EYES FRONT OFFICERS TAKE POST LEFT – TURN QUICK – MARCH INWARDS – TURN | <ul style="list-style-type: none"> – The SqnSP, under the orders of the SqnSB, marches to its position between No.1 and No. 2 flights of the squadron. |
| 9 | WGCDR | WING WILL MARCH PAST BY SQUADRONS, FLIGHTS IN LINE AT 25 PACES DISTANCE | <ul style="list-style-type: none"> – SCDRs turn about |
| 10 | SCDRs (in succession from No.1 Squadron) | NO... SQUADRON MOVE TO THE RIGHT IN COLUMN OF THREES RIGHT – TURN | <ul style="list-style-type: none"> – Flights act as in squadron drill (refer to Part 2, Chapter 3), observing a greater distance than normal. – The WGCDR takes up position, on the move, four paces in front of No.1 Squadron commander. |
| 11 | When the leading flight of each squadron approaches Point 1— | | |
| | SCDRs | No... SQUADRON CHANGE DIRECTION LEFT LEFT – WHEEL | |
| 12 | As the leading flight of each squadron reaches Point 2— | | |
| | SCDRs | FACING LEFT ADVANCE IN COLUMN | |
| 13 | When No.1 Flight of No.1 Squadron is approaching Point A— | | |
| | SCDRs | BY THE RIGHT NO... SQUADRON WILL PAY COMPLIMENTS BY FLIGHTS | |
| 14 | When No.1 Flight commander of No.1 squadron approaches Point A— | | |
| | No. 1 FLTCDR | NUMBER 1. FLIGHT EYES – RIGHT | |
| 15 | When supernumerary officers of No.1 squadron have passed Point B— | | |
| | No 1 FLTCDR | NUMBER 1. FLIGHT EYES – FRONT | <ul style="list-style-type: none"> – Having passed Point B the wing commander wheels to the right and takes position alongside the dais. – Succeeding squadrons and their flights are to act as for No.1 Squadron. |
| 16 | When No.1 Flight of No.1 Squadron is abreast of Point 3 | | |
| | PCDR | IN SUCCESSION ADVANCE IN COLUMN OF THREES FROM THE RIGHT | |

UNCLASSIFIED

UNCLASSIFIED

| Table 3-4-1 Procedure for Ceremonial Review of a Wing (cont.) | | | |
|--|---|---|--|
| Serial | Commander | Command | Action |
| 17 | No 1 FLTCDR | NO ... ONE FLIGHT MOVE TO THE RIGHT IN THREES RIGHT – TURN CHANGE DIRECTION LEFT LEFT WHEEL | <ul style="list-style-type: none"> – Any other FLTCDRs give the same command in turn as their flights come abreast of Point 3. – Subsequent squadrons act in turn when they come abreast of Point 3. |
| 18 | As each squadron approaches its position on the receiving base— | | |
| | SCDRs | NO ... SQUADRON AT THE HALT FACING LEFT FORM CLOSE COLUMN OF FLIGHTS | <ul style="list-style-type: none"> – Flights act as in squadron drill. (Refer to Part 2, Chapter 3.) |
| 19 | When all squadrons are in position the WGCDR moves back into position— | | |
| | WGCDR | OFFICERS TAKE POST IN REVIEW ORDER OUTWARDS – TURN QUICK – MARCH LEFT – TURN WING RIGHT – DRESS EYES – FRONT WING WILL ADVANCE IN REVIEW ORDER BY THE CENTRE QUICK – MARCH | <ul style="list-style-type: none"> – The wing marches forward 14 paces and halts on the 15th pace. |
| 20 | WGCDR | GENERAL/ROYAL/VICE-REGAL/ PRESIDENTIAL SALUTE PRESENT – ARMS | <ul style="list-style-type: none"> – The band plays the appropriate salute. |
| 21 | WGCDR | SHOULDER – ARMS | <ul style="list-style-type: none"> – The WGCDR reports to the reviewing officer, salutes and invites them to address the parade. – After saluting, the wing commander— <ul style="list-style-type: none"> – requests permission to carry on; – turns right; – moves to a designated position to the left of the dais; – halts; and – turns to face the parade. |
| 22 | WGCDR | WING STAND AT – EASE | <ul style="list-style-type: none"> – Wing stands at ease. – The WGCDR also stands at ease. |
| 23 | The reviewing officer delivers their address. | | |
| 24 | At the conclusion of the address by the reviewing officer, the reviewing officer's car returns to the dais. | | |
| 25 | WGCDR | WING WING –SHUN | <ul style="list-style-type: none"> – Wing comes to attention. |

UNCLASSIFIED

UNCLASSIFIED

| Table 3-4-1 Procedure for Ceremonial Review of a Wing (cont.) | | | |
|--|--|---|---|
| Serial | Commander | Command | Action |
| 26 | As the car moves from the parade ground— | | |
| | WGCDR | GENERAL/ROYAL/VICE-REGAL/ PRESIDENTIAL SALUTE PRESENT ARMS SHOULDER– ARMS | |
| 27 | When the reviewing officer has left the parade ground— | | |
| | WGCDR | OFFICERS TAKE POST LEFT TURN QUICK MARCH INWARDS TURN SQUADRON COMMANDERS MARCH YOUR SQUADRONS OFF AND DISMISS | <ul style="list-style-type: none"> – PCDRs salute, turn about and, in succession, march their squadrons off in column of route. – The band plays while the dispersal is taking place and then to marches off. |

3.4.4 Alternative procedure for the ceremonial review of a wing

- a. Where, given limitations of the local review parade ground, it is considered undesirable to march past by squadrons with flights in line, the wing may march past in column of route. If this is the case the alternative procedure outlined in Table [3-4-2](#) is to be carried out.
- b. The reception of the reviewing officer and their inspection are as detailed in the full procedure. (Refer to paragraph [3.4.3](#).)

Table 3-4-2 Alternative Procedure for Ceremonial Review of a Wing

| Serial | Commander | Command | Action |
|---------------|--|---|-------------------------------------|
| 1 | When the WGCDR has received permission to march past (Table 3-3, Serial 10), closed the wing and returned the officers to their positions— | | |
| | WGCDR | WING WILL MARCH PAST IN COLUMN OF ROUTE FROM THE RIGHT | |
| 2 | Led by No.1 Squadron— | | |
| | SCDRs | NO... SQUADRON MOVE TO THE RIGHT IN COLUMN OF ROUTE RIGHT – TURN | – Flights act as in squadron drill. |
| 3 | As the leading SCDR nears the saluting base— | | |
| | WGCDR | BY THE RIGHT COMPLIMENTS WILL BE PAID BY FLIGHTS | |
| 4 | As each FLTCDR comes abreast of Point A— | | |
| | FLTCDR | NO... FLIGHT EYES – RIGHT | |

UNCLASSIFIED

UNCLASSIFIED

NZAP 2.4 Manual of Ceremonial and Drill
 Part 3 – Ceremonial Drill
 Chapter 4 – Review of a Wing

Version 6.00
 13 June 2023

| Table 3-4-2 Alternative Procedure for Ceremonial Review of a Wing (cont.) | | | |
|--|--|---------------------|--|
| Serial | Commander | Command | Action |
| 5 | When the supernumerary officers are abreast of Point B— | | |
| | FLTCDR | EYES – FRONT | Note: No.1 Flight commander of No.1 Squadron gives the command 'EYES-RIGHT' as the wing commander arrives abreast Point A. All persons in front of them are to salute on their command. Succeeding squadrons act similarly. |
| 6 | - The leading squadron, after passing the saluting base, led by the SCDR, wheels around points 3 and 4 and proceeds to its original place on the receiving base. | | |
| 7 | - Succeeding squadrons are to act similarly so that the wing is reformed in line of squadrons in close column of flights. | | |
| 8 | - The remainder of the parade is the same as the full procedure. (Refer to paragraph 3.4.3.) | | |

UNCLASSIFIED

Chapter 5 – Service and State Funerals

Section 1 – Service funerals

3.5.1 General

- a. The regulations dealing with Service funerals are contained in [AFGO Air Force General Orders Part 11, Chapter 7, Section 3 Service Funerals and Mourning](#) and [NZAP 19 Manual of Casualty Procedure Chapter 2](#).
- b. DFI 113 *Visits, Ceremonial and Protocol* (TBI) covers funerals for officers of Air Rank who currently are serving or have served as a Chief of Air Force or Chief of Defence Force.
- c. Given that the RNZAF is a multicultural organisation, various cultural protocols must be adhered to and family preferences respected. This chapter is therefore to be used as a guide only.

3.5.2 The funeral party

The funeral party is to be drawn up outside the building in which the coffin rests, as follows—

- (1) **Escort party.** The escort party is to be at the head of the funeral party when it moves. It is to be formed up in three ranks facing the building, 20 paces from the leading flank of the band. The officer in charge of the escort party is to be three paces in front of the centre of the front rank. They are to march at the head of the escort party three paces in front of the leading section of threes.
 - (2) **Officer commanding.** The officer commanding the entire funeral party is to be in front of the officer commanding the bearer party, in a position where they can best exercise supervision.
 - (3) **Band.** The band is to form up in two ranks with one pace interval between files and ten paces between ranks, which are to face inward. The left file of the band is to be ten paces from the tender and trailer.
 - (4) **Firing party.** For firing party composition refer to [AFGO Part 11 Chapter 7, Section 3](#). The firing party is to be drawn up in two ranks at a designated location. The non-commissioned officer (NCO)/senior non-commissioned officer (SNCO) is to be two paces to the rear of the centre of the party. The corporal (CPL) is to be on the right of the front rank and the two trumpeters are to be on the left of each rank. (Refer to Part 1, Chapter 5, paragraph [1.5.24 Firing Volleys](#)).
- Note:** When burial is by cremation, no firing party is to be detailed and the ceremonial will end with the entry of the coffin into the crematorium.
- (5) **Tender and trailer.** The tender and trailer are to be drawn up in front of the entrance of the building and in front of the firing party.

- (6) **Bearer party.** For bearer party composition refer to [AFGO](#), Part 11, Chapter 7, Section 3. The person in charge of the bearer party is called the bearer party in charge (BPIC). The bearer party is to arrange the coffin inside the building, and is to ensure that the Royal New Zealand Air Force (RNZAF) Ensign, the headdress and the sword on side arms, are properly secured when the coffin is borne outside and placed on the trailer. The bearer party is also responsible for wreaths. Headdress is not to be worn when the coffin is being borne. At an officer's funeral, the bearer party is to march on the outer flanks of the pall bearers at intervals of two paces.
- (7) **Supporting party.** The pall bearers are to form up three on each side of the entrance of the building. When the coffin is placed on the trailer they are to take up their positions on each side of the trailer. At the funeral of a non-commissioned officer (NCO) or other ranks (ORs), the bearer party are also to act as pall bearers and are to take up their positions accordingly when the coffin is not being borne.
- (8) **Attending party.** The attending party is to be formed up in threes, 20 paces from the reverse flank of the firing party. They are to face in the direction in which the funeral cortege is to move. When the funeral party moves off, they are to march behind the chief mourners, who are to be immediately behind the tender, trailer and insignia bearers (if any).

3.5.3 Order of march

- a. **Escort party.** Officers of the escort are to march in reverse order of seniority from front to rear. ORs of the escort are to march in similar order to the rear of the officers.
- b. **Supporting party.** The pall bearers are to be in order of seniority alternately on either side of the coffin. The senior pall bearer is to be at the rear on the right hand side, the next senior at the rear on the left hand side, and so on.
- c. **Attending party.** Officers attending a funeral as mourners are to march in order of seniority from front to rear; they are not to draw swords. ORs of the attending party are to march in similar order but to the rear of the officers.
- d. **Representatives of other Services.** At a Service funeral that is attended by representatives of the other Services, the officers of the three Services are to march in the cortege together and not in separate groups. They are to take up positions according to their relative ranks in the order adopted by the Service to which the deceased belonged. This order is also to govern the position in the cortege of the units of members of the three Services.

3.5.4 The funeral procession

- a. The funeral procession is to be in the following order—
- (1) Officer commanding.
 - (2) Escort party (Queen'dColour (QC)/Squadron Standard (Sqns) party).

UNCLASSIFIED

NZAP 2.4 Manual of Ceremonial and Drill
 Part 3 – Ceremonial Drill
 Chapter 5 – Service and State Funerals

Version 6.00
 13 June 2023

- (3) Firing party.
 - (4) Band and trumpeters.
 - (5) Tender, trailer and coffin, bearers and pall bearers.
 - (6) Insignia bearers (if any).
 - (7) Chief mourners.
 - (8) The Queen’s representative (if any).
 - (9) Attending party.
 - (10) Any other mourners not in uniform.
 - (11) ORs lining the route (if detailed), join the procession in threes starting on the inner flank as the cortege passes.
 - (12) Motor cars or other vehicles accompanying the procession.
- b. All ranks on the active list, and officers not on the active list who are in possession of uniform, are to wear uniform when taking part in the procession if military honours are accorded at the funeral of an officer or an OR.
 - c. The bearers are to march on either side of and next to the trailer, unless there are pall bearers. When there are pall bearers, they are to march immediately on either side of the trailer with the bearers on the outer flanks at two paces interval. The position of the pall bearers is to be in order of seniority alternately as described in paragraph [3.5.3b](#).
 - d. ORs lining the route are to reverse arms in succession before moving off in slow time. When in position they are to present arms as the head of the funeral cortege approaches, after which they are to reverse arms as the firing party approaches and rest on arms reversed.
 - e. At funerals of senior officers with a large escort party, the party is to march by flights in column of route.

3.5.5 Bearer drill

- a. The detail of the commands and movements for funeral drill include those for the MARS-L and the sword.
- b. The coffin is always to be carried feet end foremost and normally the bearers are to work on the command of the officer, warrant officer (W/O) or non-commissioned officer in charge (NCOIC) of the bearer party.
- c. Words of command are to be given in a quiet, slow tone as follows—

PREPARE TO LIFT

LIFT

SLOW – MARCH

HALT**PREPARE TO LOWER****LOWER**

- These movements cannot be controlled by a signal and should always be ordered by a word of command.
- When in the lift position, the bearer party is to be evenly spaced, three on each side of the coffin.
- Their arms are to be crossed.
- The coffin is to rest on the shoulder with the bearers faces close to the side of the coffin for extra security.
- The headdresses of the bearers are to be carried by the reserve bearers.
- The bearers are to step off with the inside foot to avoid undue rocking of the coffin.
- The bearer party in charge (BPIC) is to march two paces to the rear and in the centre of the bearer party.

3.5.6 The funeral ceremony

- a. Table [3-5-1](#) shows an outline of the procedures and commands that may be used for a Service funeral Ceremony.
- b. The escort party is to be in open order.
- c. The escort and firing parties are to carry weapons at the shoulder.

Table 3-5-1 Service Funeral Ceremony Procedures and Commands

| Serial | Commander | Command | Action |
|--------|---|--|--|
| 1 | As the coffin is brought from the building— Commanders of the escort and firing parties, in succession | ESCORT/FIRING PARTY PRESENT – ARMS | <ul style="list-style-type: none"> – Escort and firing parties present arms. – The pall bearers salute as the coffin is borne out. – The pall bearers turn and march to each side of the coffin and face the direction in which the funeral party will move. – The bearer party takes up its position on the flanks of the pall bearers. |
| 2 | Commanders of the escort and firing parties, in succession | ESCORT/FIRING PARTY REVERSE – ARMS | <ul style="list-style-type: none"> – Escort and firing parties reverse arms. |
| 3 | SGT in command of the firing party | FIRING PARTY MOVE TO THE RIGHT/LEFT RIGHT/LEFT – TURN | <ul style="list-style-type: none"> – The CPL takes post two paces in front of and midway between the two files. – The SGT takes post two paces in rear of the trumpeters and midway between the files. |

UNCLASSIFIED

| Table 3-5-1 Service Funeral Ceremony Procedures and Commands (cont.) | | | |
|---|--|--|---|
| Serial | Commander | Command | Action |
| 4 | SGT in command of the firing party | FIRING PARTY SLOW – MARCH | – The firing party passes through the ranks of the band to its position four paces to the rear of the escort party. |
| 5 | SGT in command of the firing party | FIRING PARTY – HALT | – The band forms up by turning and moving inwards ready to move off. |
| 6 | Commander of the escort party | ESCORT PARTY CLOSE ORDER – MARCH MOVE TO THE RIGHT/LEFT RIGHT/LEFT – TURN | |
| 7 | When the parties have formed up and the chief mourners have taken their positions— | | |
| | Officer in command of the funeral party | FUNERAL PARTY SLOW – MARCH | <ul style="list-style-type: none"> – The band starts playing a dead march and is to continue playing for such distance as previously ordered by the commander of the funeral party. – During the slow march, arms may be changed by order of the commander of the funeral party. |
| 8 | When the band stops playing— | | |
| | Officer in command of the funeral party | INTO QUICK TIME QUICK – MARCH | <ul style="list-style-type: none"> – All parties conform to the command. – The escort and firing parties bring their rifles to the trail reversed as they change from slow to quick time. – Arms may be changed during the quick march by order of the commander of the funeral party. |

3.5.7 Arrival at the cemetery

A procedure for arrival of a Service funeral cortege at the cemetery is shown in Table [3-5-2](#).

Table 3-5-2 Procedure and Commands for Arrival of a Service Funeral Cortege at the Cemetery

| Serial | Commander | Command | Action |
|---------------|---|---|---|
| 1 | At a convenient distance from the cemetery | | |
| | Commander of the funeral party | INTO SLOW TIME SLOW – MARCH | <ul style="list-style-type: none"> – All parties conform to the command. – The escort and firing parties bring their rifles to the reverse as they change from quick to slow time. – The band starts playing a dead march. |
| 2 | When the head of the cortege arrives near the cemetery gates, or the place where it is to be met by the padre/chaplain. | | |
| | Commander of the funeral party | ESCORT PARTY FORM TWO – FILES ESCORT AND FIRING PARTIES OPEN – OUT | – The escort and firing parties open out to 10 paces interval between files. |

UNCLASSIFIED

UNCLASSIFIED

NZAP 2.4 Manual of Ceremonial and Drill
 Part 3 – Ceremonial Drill
 Chapter 5 – Service and State Funerals

Version 6.00
 13 June 2023

| Serial | Commander | Command | Action |
|---------------|--------------------------------|--|--|
| 3 | Commander of the funeral party | FUNERAL PARTY – HALT ESCORT AND FIRING PARTIES INWARDS – TURN | <ul style="list-style-type: none"> – The ranks turn to face each other. – The band conforms to the movements of the two parties. |
| 4 | Commander of the funeral party | REST ON YOUR ARMS – REVERSED | <ul style="list-style-type: none"> – The escort and firing parties rest on their arms reversed, each party takes its time from its leading NCO. |

3.5.8 Service at the cemetery

- a. The coffin is removed by the bearer party and carried feet end foremost into the chapel, where it is placed in the allotted position.
- b. The procession into the chapel is to be in the following order—
 - (1) Chaplain.
 - (2) Coffin with bearers and pall bearers.
 - (3) Chief mourners.
 - (4) Attending party.
 - (5) All of these parties are to enter the chapel if there is enough room.
- c. If there is no church service at the cemetery, the coffin is carried directly to the graveside.

Section 2 – State funerals

3.5.9 Introduction

- a. Flights are to be briefed on the direction of the procession before the funeral ceremony begins.
- b. Flights are to form up as for flight drill and are to consist of one SGT, one CPL and 24 ORs, commanded by a junior officer.

3.5.10 Taking up position on the route.

- a. Each flight is marched in column of route to its allocated position.
- b. When approximately 30 paces from the flight markers, the flight is marched on the crown of the road and the flight commander (FLTCDR) gives the command—

**NO... FLIGHT
FORM TWO – FILES**

- c. When approximately 15 paces from the flight markers the FLTCDR gives the command—
- NO... FLIGHT**
OPEN – OUT
- d. The predetermined interval between ORs when lining a route is calculated in paces and each OR is briefed to march a set number of paces past the marker before halting, the rear pair march twice the interval to allow space for the NCOs.
- e. After halting, each pair turns to face the centre of the road, orders arms, and turns their head and eyes towards the marker and dresses.
- f. The FLTCDR is to halt in the centre of the route at the head of the flight and then turn to supervise the dressing.
- g. The SGT and CPL halt level with the markers and order arms.
- h. When the FLTCDR is satisfied that the dressing is correct, they incline their head downwards as a signal to the SGT to instruct the first pair of ORs to turn their head and eyes to the front.
- i. This movement is continued through the flight by pairs of ORs in succession.
- j. When this movement is completed the NCOs start to pace out the area covered by the flight, halting after each interval to enable pairs of ORs to adjust their positions.
- k. The ORs stand at ease after the NCOs have adjusted their interval.
- l. The NCOs return to their positions between the markers and the first pair of ORs.
- m. The FLTCDR takes up position in front of the centre of the flight.

3.5.11 Procession

- a. The FLTCDR on the flank of the route lining force, which the procession first approaches, is to receive orders from the parade commander (PCDR) as to when the flight is to be brought to attention in preparation for resting on arms reversed (approximately five minutes beforehand).
- b. The commands and procedures for during the procession are shown in Table [3-5-3](#).

3.5.12 Arrival at the cemetery

- a. The band stops playing when the coffin and mourners have passed into the cemetery.
- b. The firing party, under orders from the SGT, is to—
- (a) be brought to attention;
- (b) reverse arms;

UNCLASSIFIED

Table 3-5-3 Procedure for a funeral procession

| Serial | Commander | Command | Action |
|--------|---------------------------------|---|--|
| 1 | FLTCDR | NO... FLIGHT NO... FLIGHT – SHUN NO... FLIGHT PRESENT – ARMS NO... FLIGHT REVERSE – ARMS NO... FLIGHT REST ON YOUR ARMS – REVERSED | Note: Each FLTCDR must ensure they do not give their word of command before the preceding flight has completed the movement. Each command is preceded by the flight number. |
| 2 | When the procession has passed— | | |
| | FLTCDR | NO... FLIGHT NO... FLIGHT – SHUN NO... FLIGHT PRESENT – ARMS NO... FLIGHT SHOULDER – ARMS | <ul style="list-style-type: none"> – FLTCDRs take up position in the centre of the road to supervise the re-forming of their flights |
| 3 | FLTCDR | OUTWARDS – TURN AT THE HALT ON NUMBER 1, QUICK – MARCH | <ul style="list-style-type: none"> – The leading pair of ORs stand fast. – The remainder of the flight— <ul style="list-style-type: none"> – march forward; and – halt individually, one arms distance behind the ORs in front. – The FLTCDR then— <ul style="list-style-type: none"> – marches to the head of their flight; and – halts. |
| 4 | FLTCDR | NO ... FLIGHT INWARDS WHEEL NO ... FLGIHT SHALL FORM THREE FILES | |
| 5 | When the flight is re-formed— | | |
| | FLTCDR | QUICK – MARCH | <ul style="list-style-type: none"> – While the flights are closing to the appropriate flank, the band takes up position at the head of the route lining force in preparation to marching off on the orders of the PCDR. |

UNCLASSIFIED

- (c) turn outwards into file;
 - (d) march in slow time into the cemetery;
 - (e) form up facing inwards with one rank on each side of the church entrance;
and
 - (f) rest on arms reversed.
- c. The escort party and band follow the firing party into the cemetery independently in that order, and march in slow time to the graveside to await the arrival of the coffin.
- d. The escort party carry out the movements of the details for the firing party, and rest on arms reversed after they have halted in position.

3.5.13 Procession to graveside

- a. At the end of the service, the coffin is borne feet end foremost from the church by the bearer party.
- b. The pall bearers—
- (1) form up three on each side of the door of the church;
 - (2) salute as the coffin is borne out; then
 - (3) take up their positions on each side of the coffin; and
 - (4) accompany it to the graveside.
- c. The firing party, under orders from the SGT are to—
- (1) be brought to attention;
 - (2) reverse arms;
 - (3) turn outwards into file;
 - (4) follow immediately behind the mourners and the coffin; and
 - (5) the attending party is to follow the firing party.
- Note:** During the service at the graveside (except when the actual burial takes place in a consecrated building) the headdress of those attending in uniform is not to be removed.
- d. If there is no service in the church, the funeral party enters the cemetery in the following order and moves in slow time straight to the graveside—
- (1) chaplain.
 - (2) coffin with bearers and pall bearers.
 - (3) chief mourners.
 - (4) firing party.

- (5) attending party.
- (6) escort party.
- (7) band.

3.5.14 At the graveside

- a. When the coffin arrives at the graveside, it is placed on the stretchers over the grave and the lowering ropes adjusted.
- b. The Ensign, headdress and sword/side arms, are removed from the coffin by the bearer party, after which they stand clear.
- c. The pall bearers take their places and lower the coffin into the grave, after which they stand clear so as to allow mourners to stand near the grave before the service starts.
- d. The procedure for the graveside ceremony is as shown in Table [3-5-4](#).

Table 3-5-4 Graveside Procedure at Cemetery

| Serial | Commander | Command | Action |
|--------|---|--|--|
| 1 | SGT in charge of the firing party (quietly) | FIRING PARTY FIRING PARTY – SHUN PRESENT – ARMS SHOULDER – ARMS VOLLEYS WITH BLANK ROUNDS – LOAD ACTION READY PRE – SENT FIRE | <ul style="list-style-type: none"> – After the first volley has been fired, the ORs remain at the ‘present’ until after the command FIRE is given. – Two more volleys are fired in a similar manner. – If desired, the band may play a line of a suitable hymn between each volley and the last line after the last volley. |
| 2 | SGT in charge of the firing party (quietly) | MAKE SAFE SHOULDER – ARMS | <ul style="list-style-type: none"> – Firing party— <ul style="list-style-type: none"> – make safe their arms, then – shoulder their arms. |
| 3 | Commander of the funeral party | ESCORT PARTY PRESENT – ARMS SHOULDER – ARMS | <ul style="list-style-type: none"> – Escort party <ul style="list-style-type: none"> – presents arms; then – shoulders their arms. – The trumpeters take up position at the graveside. |
| 4 | Commander of the funeral party | LAST POST PRESENT – ARMS | <ul style="list-style-type: none"> – The escort and firing parties present arms and remain at the ‘present’ while the trumpeters sound the Last Post followed by Reveille. – Officers salute while the Last Post and Reveille are being sounded. |
| 5 | Commander of the funeral party | ESCORT AND FIRING PARTIES SHOULDER – ARMS | <ul style="list-style-type: none"> – The escort and firing parties shoulder arms. |

| Table 3-5-4 Graveside Procedure at Cemetery (cont.) | | | |
|---|--------------------------------|---------|---|
| Serial | Commander | Command | Action |
| 6 | Commander of the funeral party | | – Orders the escort, firing and attending parties to move off independently and form up outside the cemetery. |

3.5.15 Forming up after the ceremony

- a. After the ceremony, parties are formed up in the following order—
- (1) Band.
 - (2) Escort party.
 - (3) Firing party.
 - (4) Attending party (including the bearers and pall bearers).
- b. Senior officers are not to join the funeral party after the service at the graveside unless they have been officially invited.

Section 3 – Alternative funeral procedure

3.5.16 General

- a. [AFGO](#) Part 11, Chapter 7, Section 3 details the composition of the following parties—
- (1) Escort.
 - (2) Firing.
 - (3) Bearer.
 - (4) Supporting (pall bearers; only for officers).
 - (5) Attending.
- b. [AFGO](#) Part 11, Chapter 7, Section 3 also stipulates entitlement to either full, simplified or limited honours.
- c. As well as detailing the drill aspect, this section suggests administrative considerations a Base Adjutant is to action before a funeral service. Although intended for a funeral service held in a base chapel for the funeral of an Air Commodore or below rank, the format is pertinent for off-base services and allows for minor adaptations for cremation services.

3.5.17 Administrative considerations

- a. The following actions need to be carried out by the officer/NCO responsible for briefing and training the funeral party—
- (1) Find out what type of service is required. The base headquarters executive officer and padre/chaplain will consult next-of-kin (NOK) for decision). Some options are as follows—
 - (a) Full, simplified or limited honours.
 - (b) Private service with military representation.
 - (c) Bearers may be either civilian or military.
 - (d) A firing party may be declined.
 - (e) The format may be flexible depending on the wishes of the NOK, but may not be radically untraditional for a service funeral.
 - (2) Find out where the burial is to take place (get the plot number from cemetery sextant).
 - (3) Request New Zealand Police assistance for point control giving times and intended route.
 - (4) Arrange white rifle slings for the firing party.
 - (5) Ensure bearers are the same size.
 - (6) Go to the cemetery and carry out a reconnaissance—
 - (a) draw a diagram of the layout (distances may be important); and
 - (b) plan—
 - (i) the position of the firing party both at the entrance and for the firing of volleys;
 - (ii) where the escort party is to position along the driveway;
 - (iii) where the bearers are to be positioned; and
 - (iv) the area for the attending party.
 - (7) Check the prayer format with the padre/chaplain and the sequence at the cemetery (normally committal/volleys/dismissal/last post).
 - (8) Arrange rehearsal times for the morning of the funeral.
 - (9) Teach slow march for the bearer, escort and firing parties.

- (10) Teach bearer drill—
 - (a) carrying the casket both at the side, and on the shoulder if a heavy person or in a narrow coffin (commands are the same as for rescue stretcher drill);
 - (b) removal of accoutrements and folding of the RNZAF Ensign; and
 - (c) firing volleys drill (no unload until after conclusion).
- (11) Check that the New Zealand Ensign, Service Dress (SD) hat, bayonet, web belt, frog and medals are taken to the funeral director for placing on the casket (they will drape the coffin and arrange the other items on the top). For a deceased officer or W/O, the accoutrements are SD hat, medals and sword in a scabbard.
- (12) Have a full rehearsal of phase of service to be held on the base.
- (13) A full rehearsal of the cemetery phase will not be possible so a full briefing with diagram will be necessary.
- (14) Liaise with the funeral director as to the time of arrival on base of the casket. (Bearers may be required to assist with placing the casket in the chapel.)
- (15) As bearers do not wear headdress, (arrange for orderlies to look after the bearers' headdress).
- (16) Medals are to be worn.
- (17) Arrange for black armbands for bearers and firing party (also for escort and attending parties if sufficient are available).
- (18) Pall bearers to be the same rank as the deceased.
- (19) If the cemetery has a flagpole, detail an NCO to lower the New Zealand Ensign during 'Last Post' and raise on sounding 'Reveille'.

Section 4 – Memorial service

3.5.18 Coffin

The coffin will be delivered and placed in position by the funeral director. However, if a catafalque party is to be mounted the bearers are to be made available to carry the coffin into the church. The coffin is to be placed with the feet end of the coffin towards and as near as practicable to the altar rails. While the wishes of the NOK are to be observed it is desirable that the lid of the coffin be affixed before the service. In the event of a Māori deceased, close liaison is to be made with the NOK and the tribal elders regarding desired traditional procedures.

3.5.19 Accoutrements on the coffin

Only those accoutrements listed in paragraph [3.5.2\(6\)](#) are to be placed on the coffin and this action must be completed as soon as the coffin has been placed in the venue of the funeral service, or preferably beforehand at the funeral parlour—

- (1) **Pall.** The New Zealand Flag is to be used. The flag is draped over the coffin in such a manner that the Union Jack falls over the left shoulder of the deceased. The RNZAF Ensign is not authorised for use as a Pall covering on any coffin unless expressly permitted by ACAF T&S.
- (2) **Headdress.** The SD hat is to be placed on top of the coffin at the head end with the peak pointing towards the feet.
- (3) **Arms.** This is to be a sword with scabbard in the case of an officer or W/O. A bayonet, scabbard and frog are used for all other ranks. They are to be placed centrally on top and point towards the feet. White webbing is to be used.
- (4) **Wreath.** A wreath may be supplied by the NOK and is to be placed on top of the coffin at the feet end.
- (5) **Medals.** Medals, as opposed to the insignia are pinned to the flag in a central position between the headdress and the arms.
- (6) **Attachment.** All items are to be securely attached to the pall with large safety pins.

3.5.20 Other preparations

- a. The insignia of the deceased, if entitled, pinned to a scarlet silk or velvet cushion, is to be placed on a table conveniently positioned near the coffin. Where space permits, the cushion should be located (in relation to the coffin) furthest from the altar rail.
- b. Lighted candles may be placed on either side (not the ends) of the coffin, but where a catafalque party is involved care must be taken to ensure they do not interfere with the positioning or movements of the catafalque party.
- c. It may be necessary to remove the front pew of the church to facilitate handling the coffin.

3.5.21 General

- a. A memorial service will be attended by the chief mourners and the attending party. The bearer quietly takes position at the rear of the chapel.
- b. At the conclusion of the service, on a signal from the officiating chaplain the bearer party moves forward and, after the funeral director has turned the coffin around, raises it to allow removal of the support trolley. Acting on command, the bearer party moves from the chapel carrying the coffin either at the side or on the shoulder as local conditions dictate.

- c. During the memorial service the remainder of the funeral party is to quietly form up on the roadway outside the chapel.

3.5.22 Procedure following memorial service

- a. **Escort party.** The escort party is always at the head of the funeral party. It is formed up in two ranks in line at open order, at such distance as to allow for the remainder of the entourage. The officer in charge of the escort party assumes normal position (but 3 paces instead of 2) as for in line or column of route. Officer's march in reverse order of seniority from front to rear; ORs likewise to the rear of the officers.
- b. **Band.** The band is to be 20 paces from the escort party and ten paces from the hearse, facing inward in two ranks at open order.
- c. **Firing party.**
- (1) This should, where possible, consist of—
 - (a) 1 SGT.
 - (b) 1 CPL.
 - (c) 10 ORs.
 - (d) 2 trumpeters.
 - (2) It is drawn up in two ranks on the opposite side of the road facing the chapel entrance.
 - (a) The SGT is two paces behind the centre of the rear rank.
 - (b) The CPL is one pace to the right of the front rank.
 - (c) Trumpeters are on the left of both ranks.
- d. **Hearse.** This is drawn up in front of the firing party.
- e. **Support party.** The pall bearers form up three on each side of the chapel entrance. When the coffin is placed in the hearse they form up evenly on both sides. Pall bearers salute in succession as the coffin passes their front after coming out of the *chapel*.
- Note:** As the casket is brought out of the chapel the escort and firing parties, under orders of their commanders, present arms. Personnel in uniform and not under orders salute
- f. **Chief mourners.** This party moves behind the hearse and in front of the attending party.
- g. **Attending party.** The attending party forms up in three ranks facing the direction the funeral cortege is to move. Officers march in order of seniority from front to rear; ORs are to do likewise to the rear of the officers. If the number comprising the chief mourner's party is so large as to preclude the attending party being present at the memorial service, the attending party forms up leaving a sufficiently large space for the chief mourners.

- h. When the casket has been placed in the hearse, commanders of escort and firing parties give the command to shoulder arms. The firing party is to be turned and slow marched into position by moving between the ranks of the band. The band and escort party are brought to close order; turned in the direction of march and the band reforms. This is the normal formation when the cortege is to move from the chapel to the deceased's place of work on base, or to a mess or club before leaving base for the cemetery. When all parties have formed up and the chief mourners have taken up their positions the officer in charge of the funeral party gives the command—

FUNERAL PARTY

SLOW MARCH

- The band starts to play a 'Dead March' for such distance as previously ordered.
- The final on-base respect to the deceased is provided by the escort and firing parties halting at a predetermined position on the verge of the roadway, turning inwards and presenting arms when ordered in succession as the hearse passes.
- When the cortege has passed through the ranks and is halted, officers in charge of each party march their ORs to waiting vehicles, ready to move to the cemetery.

Note: Where time precludes escort and firing parties being taught reverse arms movements, marching in slow time at the shoulder is acceptable, except for funerals of a single Service chief.

Section 5 – Procession to and arrival at the cemetery

3.5.23 Order of procession to the cemetery

- a. The escort party, firing party and band drive directly to the cemetery ahead of the remainder of the entourage.
- b. The firing party form up in two ranks at the cemetery entrance to await the arrival of the cortege.
- c. The escort party line the route in the vicinity of the grave/crematorium on the driveway.
- d. The order of the procession from the base to the cemetery should be—
 - (1) hearse;
 - (2) chief mourners;

- (3) bearers and pall bearers; and
- (4) remainder in any order.

3.5.24 Arrival at the cemetery.

- a. When the hearse approaches the cemetery entrance, the bearer party and firing party, which will have formed up inside the entrance facing the direction of march, are brought to attention, together with the escort party.
- b. The escort and firing parties shoulder arms.
- c. When the hearse reaches the entrance, the band master gives the command—

BAND AND FIRING PARTY – SLOW MARCH

- Members of the escort party present arms individually as the hearse proceeds through its ranks, after which they resume the shoulder arms position.
 - The procession halts at a predetermined spot and the coffin is removed by the bearers.
- d. If there is some small distance to the grave the order of procession should be—
 - (1) officiating minister;
 - (2) coffin, with pall bearers and bearers;
 - (3) chief mourners;
 - (4) attending party;
 - (5) firing party.
 - e. The bearers carry the coffin feet end foremost to the grave, place it on the supports and, in the case of a deceased W/O or below, remove all accoutrements and stand clear to allow the mourners near the grave.
 - f. In the case of a deceased officer the bearers stand clear as soon as the coffin has been placed on the supports to allow the pall bearers to remove the accoutrements.

Note: If no mechanical lowering apparatus is available the bearers remain at the graveside and act under the direction of the civilian funeral director, after which they retire.
 - g. In the meantime the firing party is halted by the SGT at a discreet distance from the graveside.

Section 6 – Interment service

3.5.25 Procedure for an internment service

- a. When the coffin has been lowered into the grave and the chaplain has finished the committal, the SGT in charge of the firing party quietly gives the following commands—

FIRING PARTY

FIRING PARTY – SHUN

LOAD

ACTION

READY

PRE – SENT

FIRE

- After the first volley has been fired, the firing party remain at the ‘PRESENT’ until the command ‘FIRE’ is given.
- Two more volleys are fired in a similar manner.
- After the third volley safety catches are to be applied.
- The SGT gives the commands to shoulder arms and stand at ease.

- b. When the chaplain concludes the ‘dismissal’—

- (1) the commander of the funeral party brings both escort and firing parties to attention; and
- (2) the trumpeters position themselves near the graveside.

- c. The commander of the funeral party then gives the command—

LAST POST

PRESENT – ARMS

- Both parties remain at the ‘PRESENT’ while the trumpeters sound the ‘Last Post’ followed by ‘Reveille’.
- All personnel in uniform and not under command salute during the sounding of ‘Last Post’ and ‘Reveille’.

- d. The commander of the funeral party then orders ‘SHOULDER - ARMS’. The escort and firing parties reform behind the band, which on command, steps off playing cheerful music. The funeral party marches to the cemetery entrance for dismissal.

- e. At this point final respects may be paid by personnel filing past the grave and saluting.

Note: Loading the magazine with six blanks rounds will assist proper feeding. The unload drill and rifle inspection is carried out by the SGT when the commander of the funeral party dismisses at the cemetery entrance.

3.5.26 After internment

- a. The funeral party marches off under the orders of the officer in command.
Note: Officers remove black armbands before the party is marched off.
- b. When the party is well clear of the cemetery the band plays cheerful music.
- c. The party is now to be called 'Royal New Zealand Air Force'

Section 7 – Māori funeral procedure

3.5.27 Cultural significance

The death of Māori serviceperson has vastly different cultural significance to that of personnel of other descents. In all instances involving the death of a Māori serviceperson, there must be consultation with the Māori Cultural Advisor (Air Force) and the RNZAF kaumātua, who in turn will liaise with the local kaumātua at the funeral site.

Chapter 6 – Cenotaph Drill

3.6.1 Cenotaph drill

- a. Refer to DFI 113 *Visits, Ceremonial and Protocol* (TBI). The following order of service should be used as a guide only. In every instance the Royal New Zealand Air Force (RNZAF) Ceremonial and Protocol Warrant Officer (W/O) will advise.
- b. Four sentries armed with rifles but without bayonets, under the command of a senior non-commissioned officer (SNCO) form up at the cenotaph 10 minutes before the time set for the wreath laying.
- c. Acting under the command of the non-commissioned officer in charge (NCOIC), the sentries informally adopt the position of 'Reverse Arms' then formally march in slow time to their positions one at each corner of the cenotaph.
- d. When in position and acting under the command of the NCOIC they go to the position of 'Rest on Arms Reversed'.
- e. The wreath laying ceremony takes place.
- f. The NCOIC accepts each wreath from the padre/chaplain conducting the service and lays them on alternate sides of the front of the memorial, on racks, which should be provided.
- g. A brief religious service follows the wreath laying.
- h. At the end of the blessing, those present are called to attention as the 'Last Post' and 'Reveille' are sounded.
- i. Sentries 'present arms' and after the 'Reveille' return to the 'rest on arms reversed'.
- j. The normal custom for RNZAF officers is to salute at the 'Last Post' and hold the salute until the end of 'Reveille', however, given the frequent tri-Service nature of these parades, there is often a conflict of individual Service customs. Officers should prearrange with organisers and/or attending other Service officers an agreed format for saluting. Saluting for only the 'Last Post' is a common preference.
- k. After those attending the parade have departed the cenotaph, acting under the orders of the NCOIC, sentries are to 'reverse arms' and march off the cenotaph in slow time.

Chapter 7 – Guards of Honour

3.7.1 General

The occasions on which guards of honour are to attend, and their compositions are laid down in DFI.113 *Visits, Ceremonial and Protocol* (TBI), Part 2, [Chapter 2](#). An exception is that when the Queen's Colour (QC) and a Squadron Standard (SqNS) are paraded together there are to be four officers (one flight lieutenant and three junior officers), one of whom is to be the Queen's Colour bearer (QCB) and another the Squadron Standard bearer (SqNSB). The QC is to be paraded for royal and presidential guards of honour.

3.7.2 Formation of the guard

A guard of honour may be formed up in—

- (1) line; or
- (2) column of route

3.7.3 Queen's Colour/Squadron Standard drill and procedure

For details on procedures when the QC/SqNS are carried on a guard of honour refer to [Part 4](#) of this publication.

3.7.4 Mounting a guard of honour

- a. **Preparation before mounting.** The guard is to be paraded at a predetermined assembly area under the command of a senior non-commissioned officer (SNCO), who is to—
 - (1) size the guard (in two ranks); and
 - (2) prepare them for inspection in open order—
 - (a) during the sizing of the guard, the guard commander (GCDR) takes up a position eight paces in front of, and facing, the guard;
 - (b) the SNCO hands over the guard to the GCDR for their inspection;
 - (c) the GCDR, accompanied by the SNCO, inspects the guard; and
 - (d) at the completion of the preliminary inspection the SNCO takes up their position in the guard.
- b. **1st and 2nd officers.** During the inspection of the guard the 1st and 2nd officers take up a positions (side by side) about eight paces to the left of the guard and three paces forward of the front rank, the 2nd officer on the right. They stand at ease in this position awaiting the command to fall in from the GCDR.

- c. **Fall in of the officers.** The procedure for the falling in of officers for a guard of honour and the arrival of the reviewing officer/very important person(s) (VIP(s)) is shown in Table [3-7-1](#).

Table 3-7-1 Falling in of Officers for a Guard of Honour and arrival of VIP(s)

| Serial | Commander | Command | Action |
|--|---|--|---|
| 1 | GCDR | FALL IN THE OFFICERS | <ul style="list-style-type: none"> - The 1st and 2nd officers— - come to attention; - salute; - turn right; and - march to their position as for the guard in line. - The GCDR returns their salutes. |
| Note: 100-person guards are to have three officers and 50-person guards are to have two officers. For tri-Service guards of honour refer to DFI 113 (TBI) and NZ P6A NZ Army Ceremonial, Chapter 8. | | | |
| 2 | When 1st and 2nd officers are in position— | | |
| | GCDR | GUARD OF HONOUR CLOSE ORDER – MARCH FORM THREE – RANKS RIGHT – DRESS EYES – FRONT | <ul style="list-style-type: none"> - During the right dress, the 1st and 2nd officers reposition themselves along the front of the guard; the 2nd officer in the centre of the guard and the 1st officer about half the frontage from the 2nd officer to the left of the guard. |
| 3 | GCDR | OFFICERS DRAW – SWORDS | <ul style="list-style-type: none"> - Officers draw swords, taking the time from the GCDR. |
| 4 | GCDR | GUARD OF HONOUR SHOULDER – ARMS MOVE TO THE RIGHT IN COLUMN OF ROUTE RIGHT – TURN | <ul style="list-style-type: none"> - The 1st and 2nd officers turn right. - The GCDR waits for the 1st and 2nd officers to turn about and step off together. - The officers take up their position in column of route. - The GCDR waits for the band to take up its position. |
| 5 | GCDR | GUARD OF HONOUR BY THE LEFT QUICK MARCH | |
| 6 | When the guard arrives at the place where it is to receive the personage— | | |
| | GCDR | GUARD OF HONOUR HALT GUARD WILL ADVANCE LEFT – TURN | <ul style="list-style-type: none"> - All officers turn to the left with the guard. - Stepping off together, the 1st and 2nd officers take up their positions in front of the guard as for in-line. - The GCDR may take up a centre position facing the guard. |

| Table 3-7-1 Falling in of Officers for a Guard of Honour and Arrival of VIP(s) (cont.) | | | |
|---|--|---|---|
| Serial | Commander | Command | Action |
| 7 | GCDR | GUARD OF HONOUR FORM TWO – RANKS WITHOUT INTERVALS IN OPEN ORDER – RIGHT – DRESS | <ul style="list-style-type: none"> – On the command 'DRESS', the two right flank SNCOs— – shoulder arms; – turn right; – march out five paces; – turn about; and – dress their respective ranks. – The rear rank SNCO ensures that the distance between the ranks is four paces. |
| Note: When moving to open order in two ranks, the rear rank only moves two paces backward; the 1st and 2nd officers reposition themselves along the front. | | | |
| 8 | GCDR | EYES – FRONT | <ul style="list-style-type: none"> – The SNCOs— – march in five paces; – halt; – turn to the front; – order arms; and – take up dressing without intervals. |
| 9 | GCDR | GUARD OF HONOUR STAND AT – EASE | <ul style="list-style-type: none"> – Guards stand at ease. – The GCDR— – marches to their position for a guard in line; and – stands at ease. |
| Arrival of the reviewing officer/VIPs. | | | |
| 10 | When the personage reaches a position about 50 m away— | | |
| | GCDR | GUARD OF HONOUR GUARD – SHUN | |
| 11 | When the personage has taken up position— | | |
| | GCDR | GUARD OF HONOUR GENERAL/ROYAL/VICE-REGAL/ PRESIDENTIAL SALUTE PRESENT – ARMS | <ul style="list-style-type: none"> – Guards present arms – The band plays the appropriate salute/anthem. |
| 12 | GCDR | GUARD OF HONOUR SHOULDER – ARMS | <ul style="list-style-type: none"> – Guards shoulder arms |
| 13 | The GCDR— <ul style="list-style-type: none"> – moves out to the personage; – salutes the personage; and – reports to them that the guard is ready for inspection. | | |

| Table 3-7-1 Falling in of Officers for a Guard of Honour and Arrival of VIP(s) (cont.) | | | |
|---|------------------------|---|---|
| Serial | Commander | Command | Action |
| 14 | GCDR | ROYAL NEW ZEALAND AIR FORCE GUARD OF HONOUR READY FOR YOUR INSPECTION, SIR/MA'AM | <ul style="list-style-type: none"> – The GCDR turns right and accompanies the personage on the inspection. – At all times the inspecting officer is to be nearest the rank being inspected, and this will entail the GCDR changing sides when passing around the left flank of the front rank. – The band plays appropriate music during the inspection. – The QC (if paraded) is saluted when passed in front of during inspection of the front rank. – After the inspection, it is normal for the personage, accompanied by a senior officer, to move away from the immediate area. – If this is the case, the GCDR salutes the personage and returns to a position in front of and facing the guard. |
| 15 | Dismissal of the guard | | |
| | GCDR | | <ul style="list-style-type: none"> – The guard is formed into three ranks, dressed and marched off in column of route to be dismissed. – The band leads. |

- d. The QC is to be paraded for all royal or presidential guards of honour.
- e. On dismissal, officers—
- (1) form a half circle in front of the guard commander;
 - (2) return swords together taking the time from the guard commander;
 - (3) pause, then turn to the right;
 - (4) march around behind the guard commander;
 - (5) halt; and
 - (6) turn into line.
- f. All officers march from the area together.
- g. If/when the guard has to divide into two halves for parades with the QC, the smallest ORs in the guard are to flank the Colour Party. The two halves are not to be re-sized.

UNCLASSIFIED

NZAP 2.4 Manual of Ceremonial and Drill
 Part 3 – Ceremonial Drill
 Chapter 7 – Guards of Honour

Version 6.00
 13 June 2023

3.7.5 Guards of honour at parliament

- a. When it is necessary to parade a guard of honour at parliament, a warning order and administration instruction providing all the details will be issued by the Heritage Commemorations and Protocol Group (HCP).
- b. After obtaining the approval of the administration officer at parliament to do so, the guard forms up in a suitable place before marching on.
- c. When in position in front of the statue, the rear rank of the guard should be as close as possible to the rear steps to allow adequate space for the QC/SqnS, if carried, and the movement of cars between the guard and the main steps.
- d. A dais is not used on the occasion of the State Opening of Parliament.
- e. For any 'royal' salutes 'British Nation Anthem' is to be played.
- f. Additional information will be available, if required, from the Deputy Director Visits and Ceremonial, HCP.

3.7.6 VIP visit to a base

- a. Details of the ceremonial welcome for some very important persons (VIPs) and all very, very important persons (VVIPs) will be advised by the Department of Internal Affairs, therefore the following procedures are intended as a general guide only.
- b. On alighting from the aircraft, the VIP is met by—
 - (1) Chief of Air Force (CAF);
 - (2) base commander (BCDR), or other commanders as deemed appropriate; and
 - (3) other government and Defence officials.
- c. After being welcomed, the VIP is escorted to the dais at the saluting base.
 - (1) Other members of the party move to the saluting base area.
 - (2) The VIP ascends the dais and takes up a position facing the guard of honour.
 - (3) The official party take up their positions at the rear of the saluting base in order of status from left to right.
- d. When the VIP is in position on the dais the formal ceremony of welcome begins—
 - (1) The guard commander gives the commands—

GUARD OF HONOUR
ROYAL/VICE REGAL/PRESIDENTIAL/GENEREAL SALUTE
PRESENT – ARMS
 - (2) The band plays the appropriate salute/anthem.

SHOULDER – ARMS

UNCLASSIFIED

NZAP 2.4 Manual of Ceremonial and Drill
Part 3 – Ceremonial Drill
Chapter 7 – Guards of Honour

Version 6.00
13 June 2023

- e. At the conclusion of the salute, the guard commander advances to the dais and invites the VIP to inspect the guard.
 - (1) The VIP, escorted by the guard commander, inspects the guard and is then escorted by the guard commander to the official party, which should be positioned at a point to the right and alongside the saluting base.
 - (2) The guard commander pays compliments to the VIP and takes up position in front of the guard.
 - (3) The VIP and official party depart from the area.
- f. If considered desirable, and if the VIP departs the saluting base by car, a further royal/vice-regal/presidential/general salute may be given.
- g. Flags—
 - (1) If the VIP is entitled to fly a personal flag or standard this should be flown from a mast above the dais.
 - (3) For presidential and vice presidential visits, and visits by prime ministers and other national leaders, the appropriate national flag is flown on a flagpole to the left of the saluting base facing the guard.
 - (4) The New Zealand national flag is to be flown from a similar position on the right of the saluting base. Both flags are to be the same size and flown from the same height.

Note: Unless directed by the Department of Internal Affairs to fly national flags during a welcoming ceremony they are not to be flown without the approval of Air Staff.

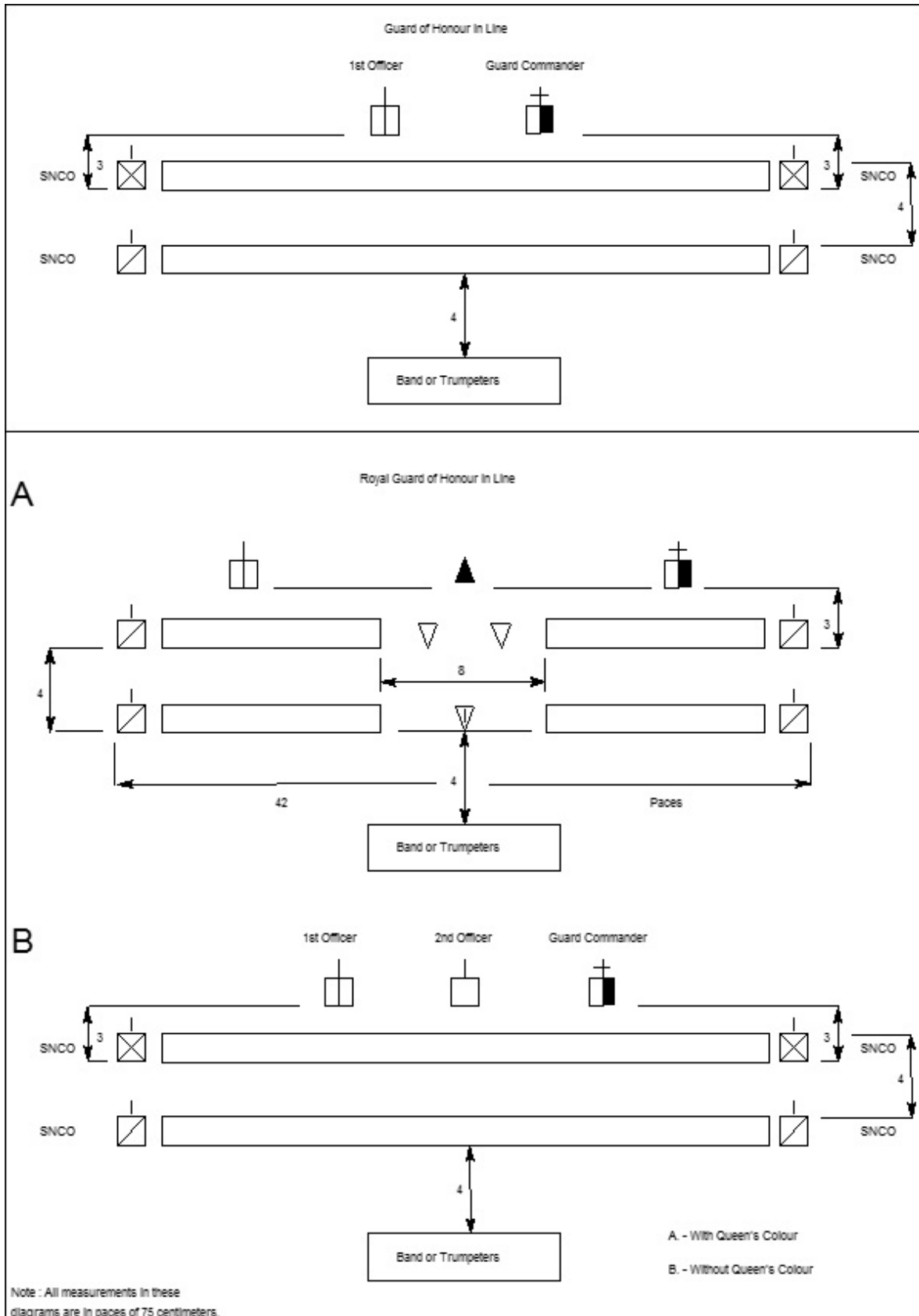

Figure 3-7-1 Formations for Guards of Honour

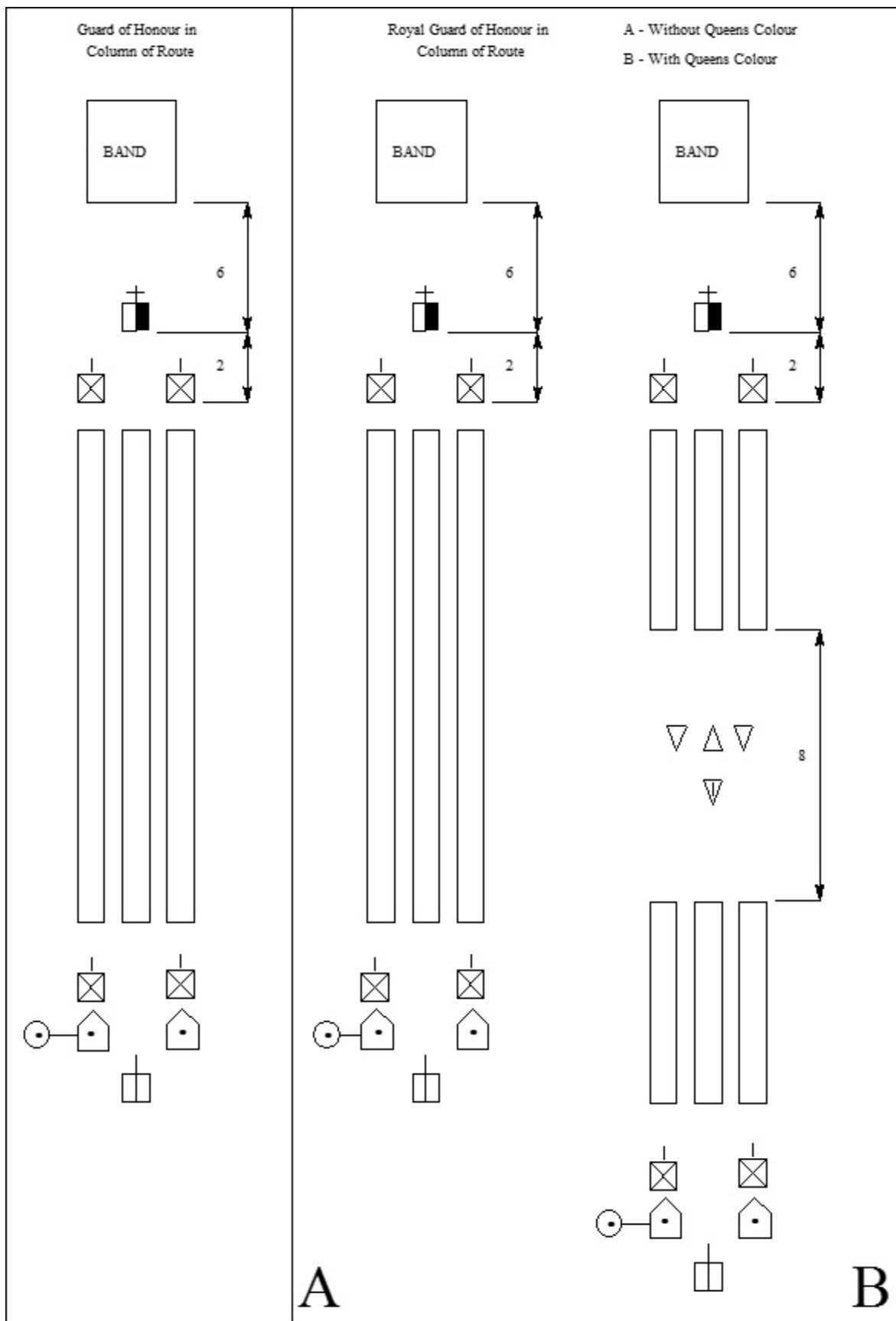

Figure 3-7-2 Royal Guard of Honour in Column of Route with and without the Queen's Colour

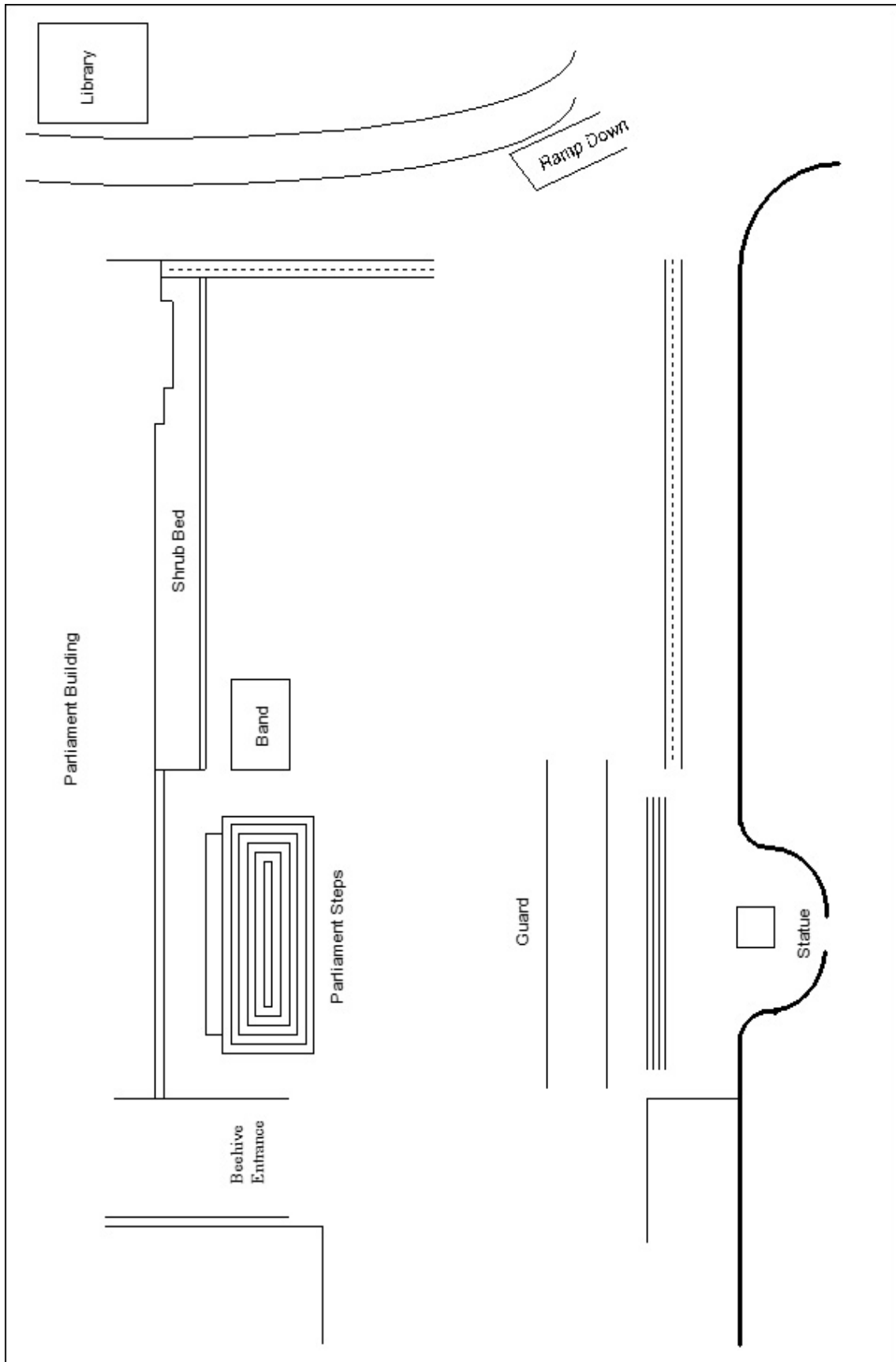

Figure 3-7-3 Layout of Parliament Grounds for Guards of Honour

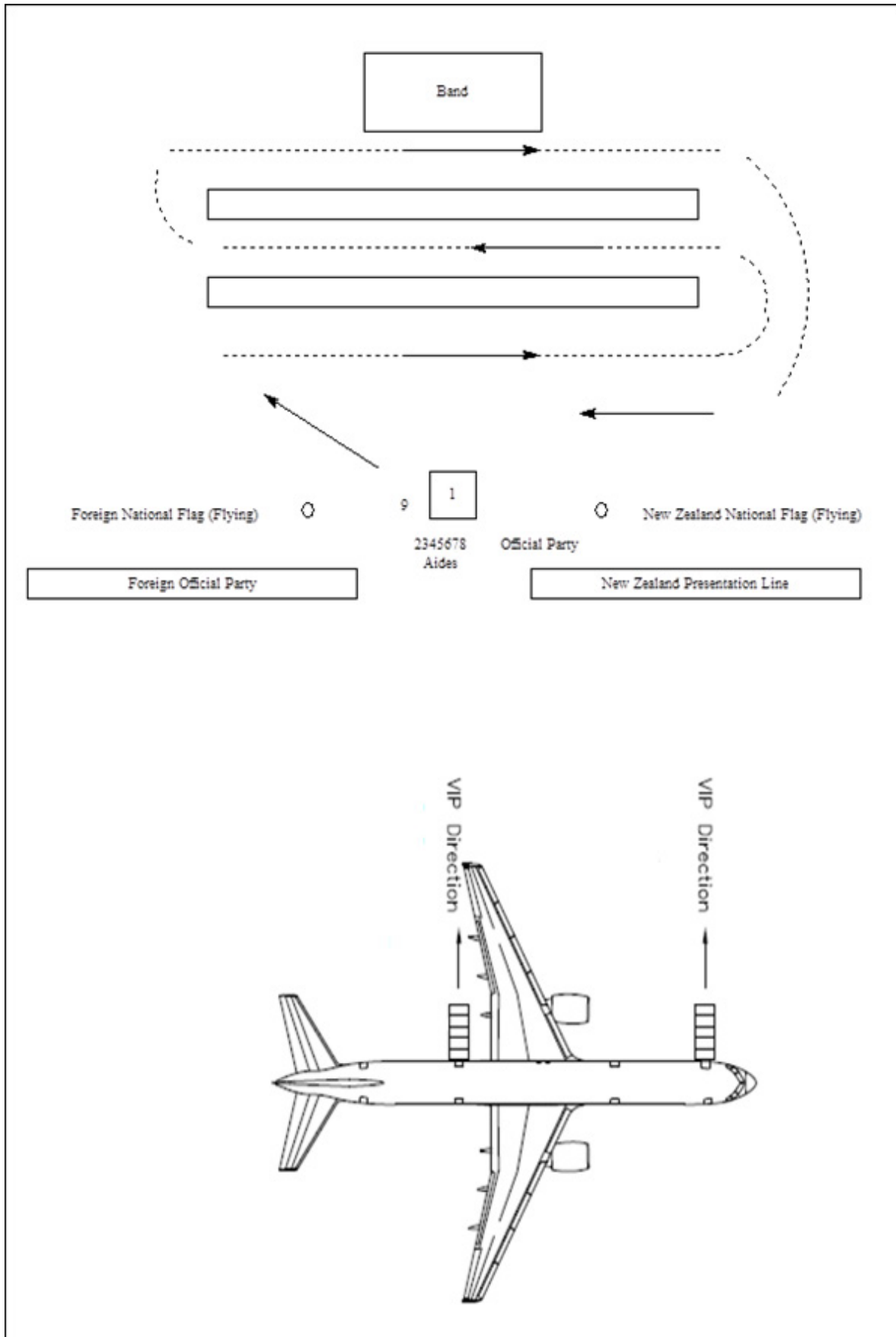

Figure 3-7-4 Layout for Ceremony of Welcome for a VIP/VVIP

Chapter 8 – Royal Guards at Government House

3.8.1 Royal Guards at Government House

Royal Guards at Government House will be Tri-Service, mandated by Parliament and managed by the Heritage, Commemoration and Protocol Group. Refer to DFI 113 *Visits, Ceremonial and Protocol* (TBI).

Chapter 9 – Quarter Guards

3.9.1 Mounting a quarter guard

- a. Under normal circumstances, when a guard of honour is not provided, a quarter guard is paraded when a very important person (VIP) is visiting or passing through a base or principal headquarters.
- b. A quarter guard may be ordered in place of a larger guard on request by the Heritage Ceremonial and Protocols Group (HCP), Headquarters of New Zealand Defence Force (HQNZDF) as directed by the various levels of higher command, and in consultation with local command.
- c. A quarter guard may be mounted at a point of entry or departure as a drive-by guard or other areas on base as directed by base headquarters.

3.9.2 Quarter guard composition

- a. A quarter guard is to consist of four junior ranks (JRs) commanded by a corporal (CPL), together with a bugler, (a drummer can replace the bugler).
- b. With the exception of the bugler, all members of the quarter guard are to be armed with rifles fitted with bayonets and white ceremonial slings.
- c. All members of the guard are to wear white gloves.
- d. The CPL is to wear the ceremonial quarter guard sash.
- e. If a quarter guard is to be mounted at the Tūrangawaewae on RNZAF Base Ohakea, the guard non-commissioned officer (NCO) is to be unarmed to allow for ease of engagement with the VIP.

3.9.3 Arrivals and departures by vehicle at the main gate

- a. **Formation.** Quarter guards for main gate arrivals and departures are to be formed up as follows—
 - (1) The CPL is to be on the right hand flank nearest the direction from which the personage will approach, two paces from the guard on the same alignment.
 - (2) The guard must be sited so that the CPL is nearest to the approach of the VIP.
 - (3) JRs are to be in single rank with an arm's length interval between them.
 - (4) The bugler is to be two paces on the left flank of the guard on the same alignment.
- b. **Procedure.** The guard is marched into position at the main entrance to the base and positioned as in Figure [3-9-1](#) (position (A) for arrivals, and position (B) for departures). Before the vehicle carrying the personage arrives, the guard is to be at the 'shoulder' ready to pay compliments. Table [3-9-1](#) outlines the format.

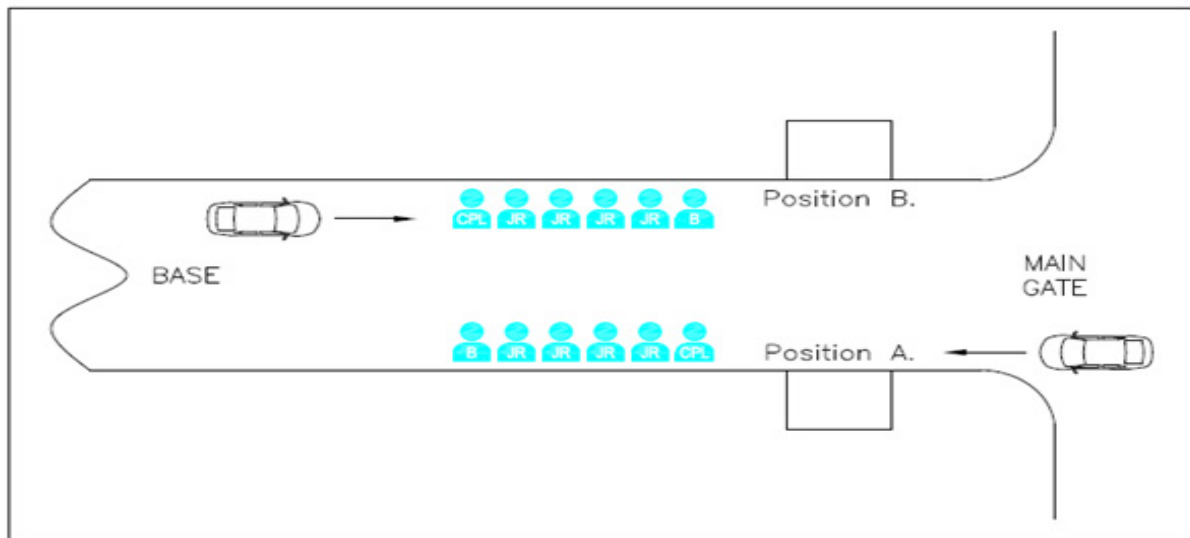

Figure 3-9-1 Layout for a Quarter Guard at the Main Gate

3.9.4 Procedure for aircraft arrivals

- a. Formation. The CPL is to be on the right hand flank nearest the direction from which the personage will approach, two paces from the guard on the same alignment. The guard must be sited so that the CPL is nearest the approach of the VIP.
- b. Procedure. After the aircraft has stopped its engines, the guard is marched into position dependent upon the aircraft type and door position, refer to Figure 3-9-2, Figure 3-9-3 and Figure 3-9-4. The formats for arrivals are described in Table 3-9-2.
- c. Position. The guard halts in a position so as not to impede the movement of the welcoming guest/VIP parties in the area of the aircraft steps. The guard halts, advance, then right dress and eyes front and to remain at attention.

Note: It is normal for personal welcomes/greetings to be made by the reception party before the quarter guard pays compliments.

3.9.5 Procedure for aircraft departures

- a. Quarter guards for aircraft departures are the reverse of the arrivals procedure, refer to Figure 3-9-5, Figure 3-9-6 and Figure 3-9-7. The formats for departures are in Table 3-9-2.

UNCLASSIFIED

Table 3-9-1 Format for Quarter Guard at Main Gate

| Serial | Commander | Command | Action |
|--------|--|---|---|
| 1 | As the VIP vehicle approaches— | | |
| | Bugler | | – Bugler plays the alert. |
| | Guard CDR | GUARD GUARD SHUN | – Guards come to attention. |
| 2 | The vehicle stops before the guard with the VIP door opposite the centre of the guard. The personage steps out. | | |
| 3 | Guard CDR | GUARD GENERAL SALUTE PRESENT – ARMS | – Bugler plays the general salute. |
| 4 | If the VIP is going to inspect the guard, the CPL/guard CDR proceeds as follows— | | |
| | CPL/guard CDR | GUARD SHOULDER – ARMS | <ul style="list-style-type: none"> – The CPL— – marches out two paces from the VIP; – salutes; and – reports that the guard is ready for inspection. – The CPL accompanies the VIP on inspection. – On completion of the inspection the CPL escorts the VIP back to the vehicle. – The CPL salutes and returns to their position on the right flank. |
| 5 | As the VIP vehicle moves away— | | |
| | CPL/guard CDR | GUARD GENERAL SALUTE PRESENT – ARMS | – Bugler plays the general salute. |
| 6 | After vehicle has moved away and the bugler has finished— | | |
| | CPL/guard CDR | GUARD SHOULDER ARMS MOVE TO THE LEFT/RIGHT IN FILE – LEFT/RIGHT TURN QUICK – MARCH | – Guard marches off and is dismissed. |

UNCLASSIFIED

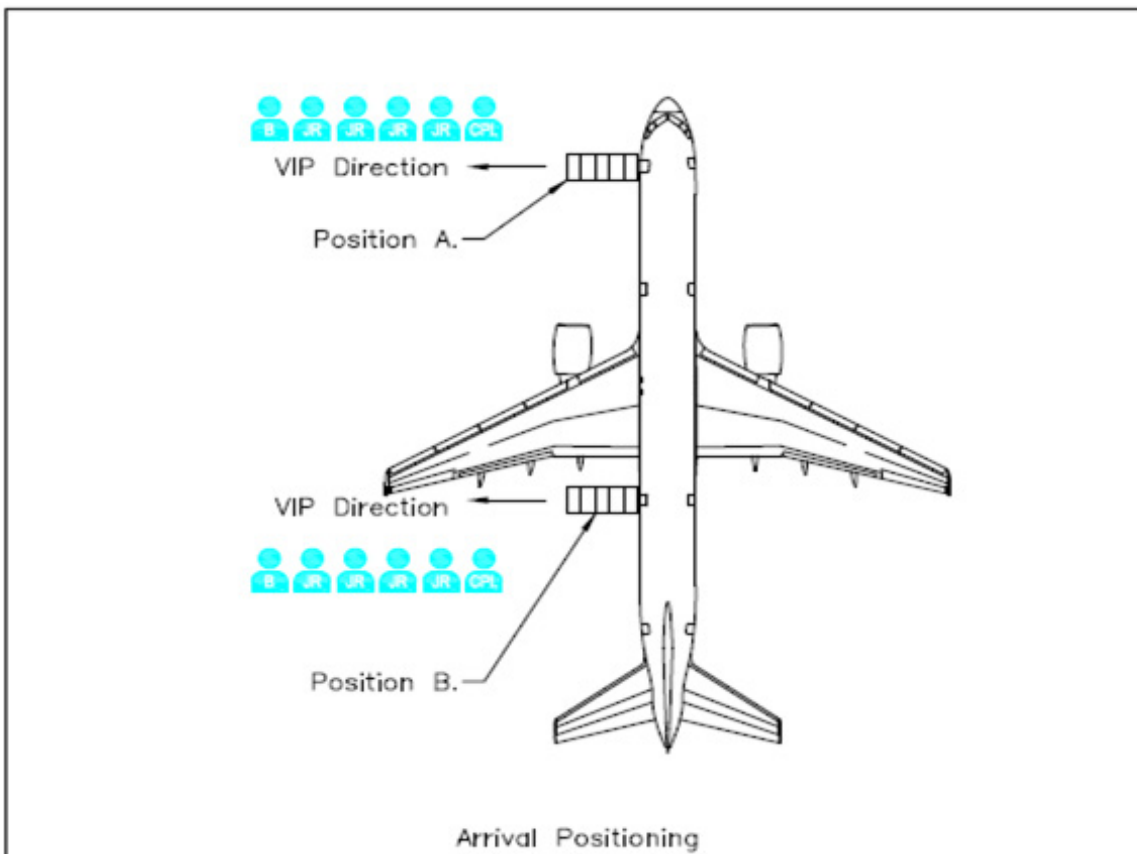

Figure 3-9-2 Layouts for a Large Aircraft Arrival

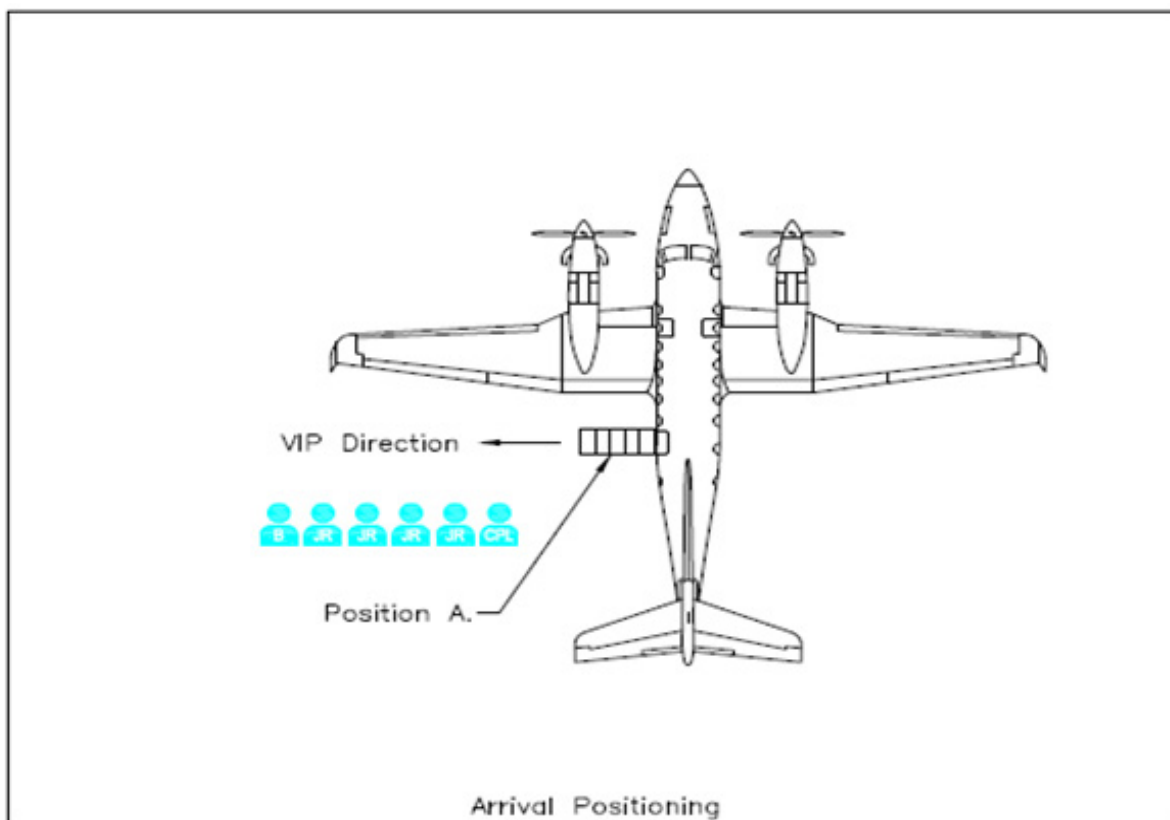

Figure 3-9-3 Layout for a Small Aircraft Arrival

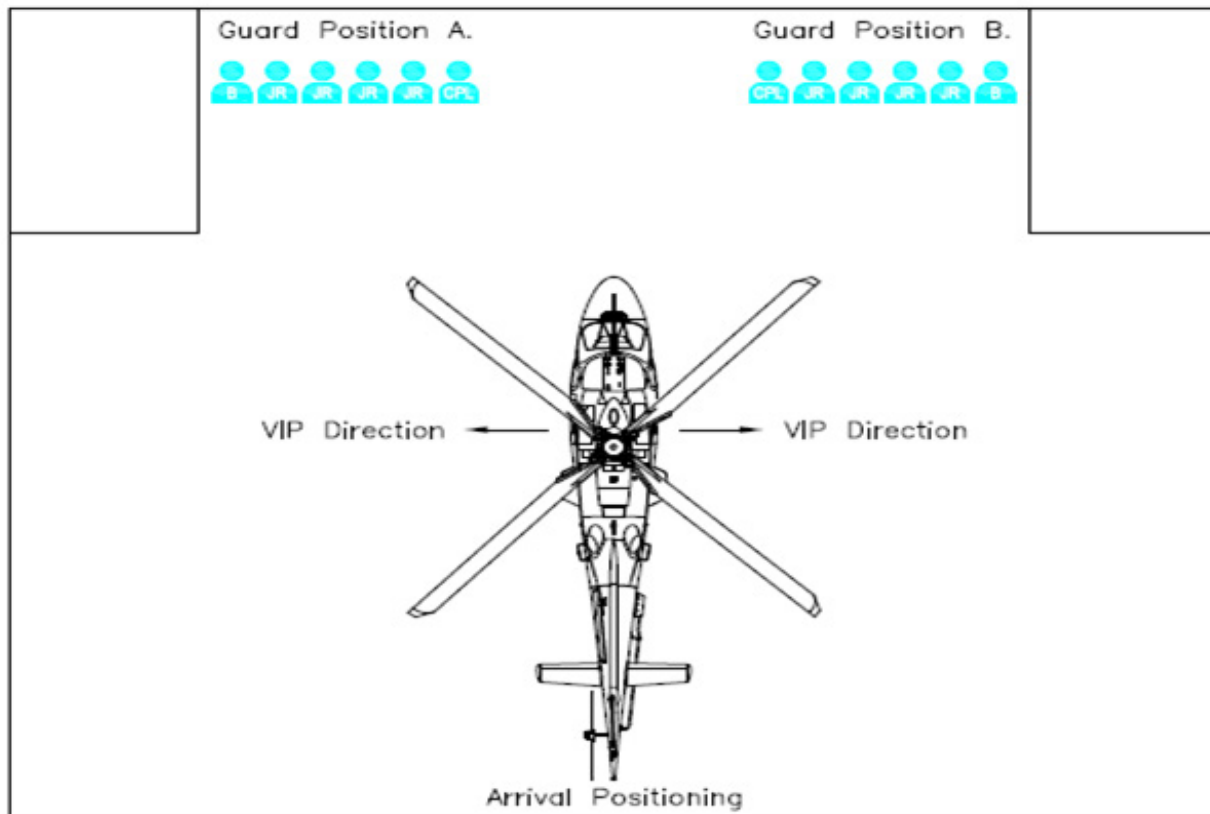

Figure 3-9-4 Layouts for a Helicopter Arrival

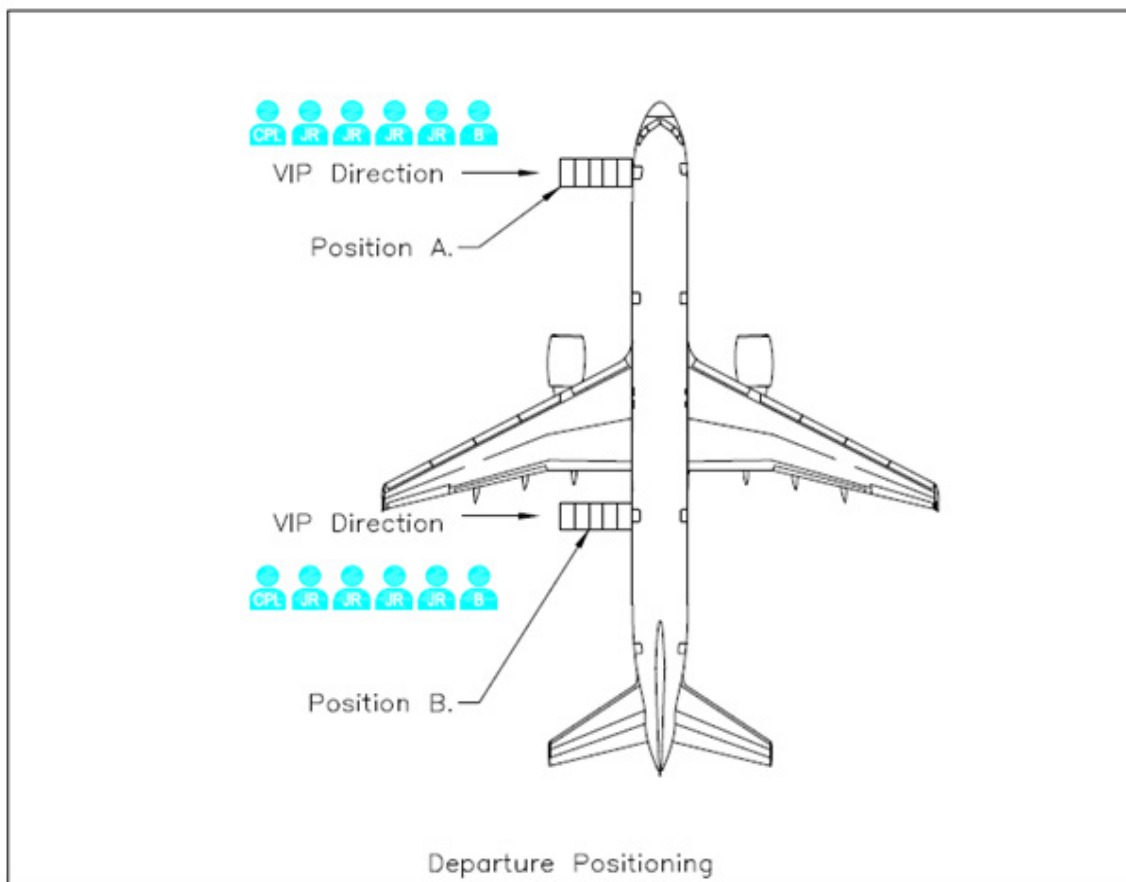

Figure 3-9-5 Layouts for Large Aircraft Departures

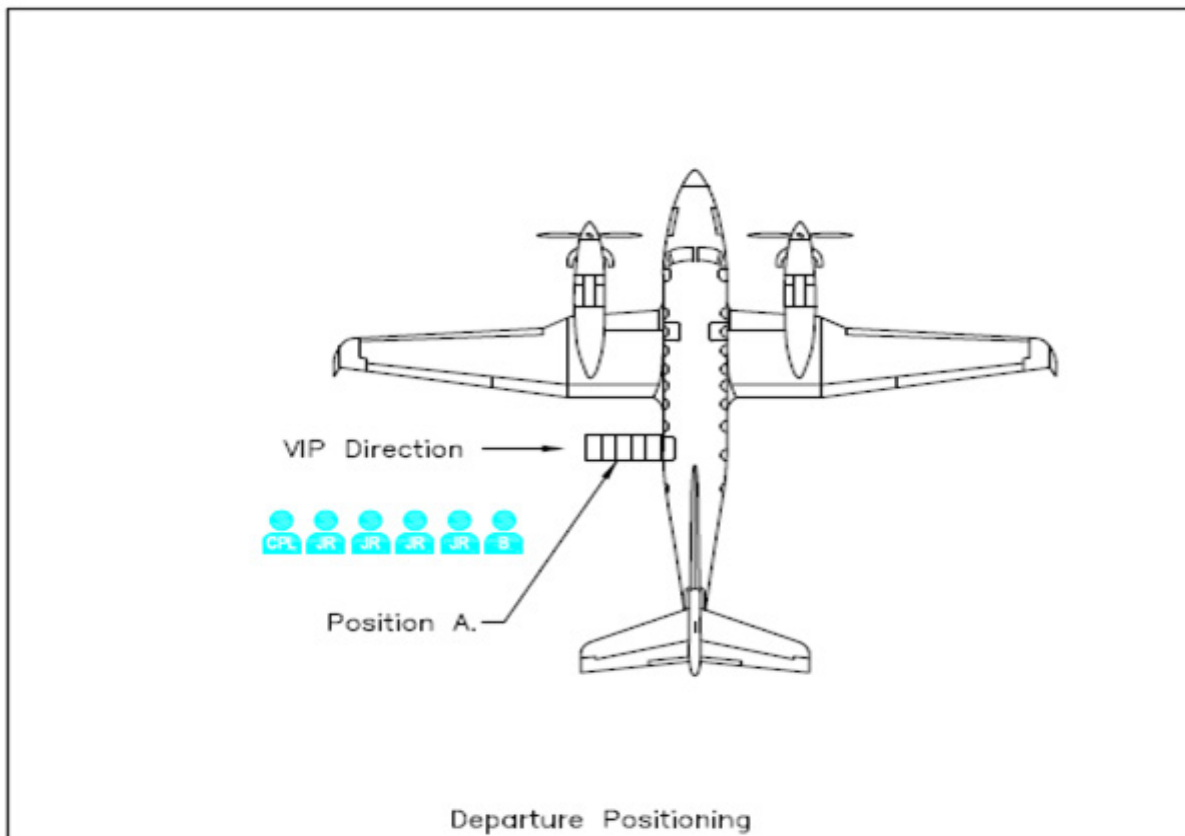

Figure 3-9-6 Layout for Small Aircraft Departures

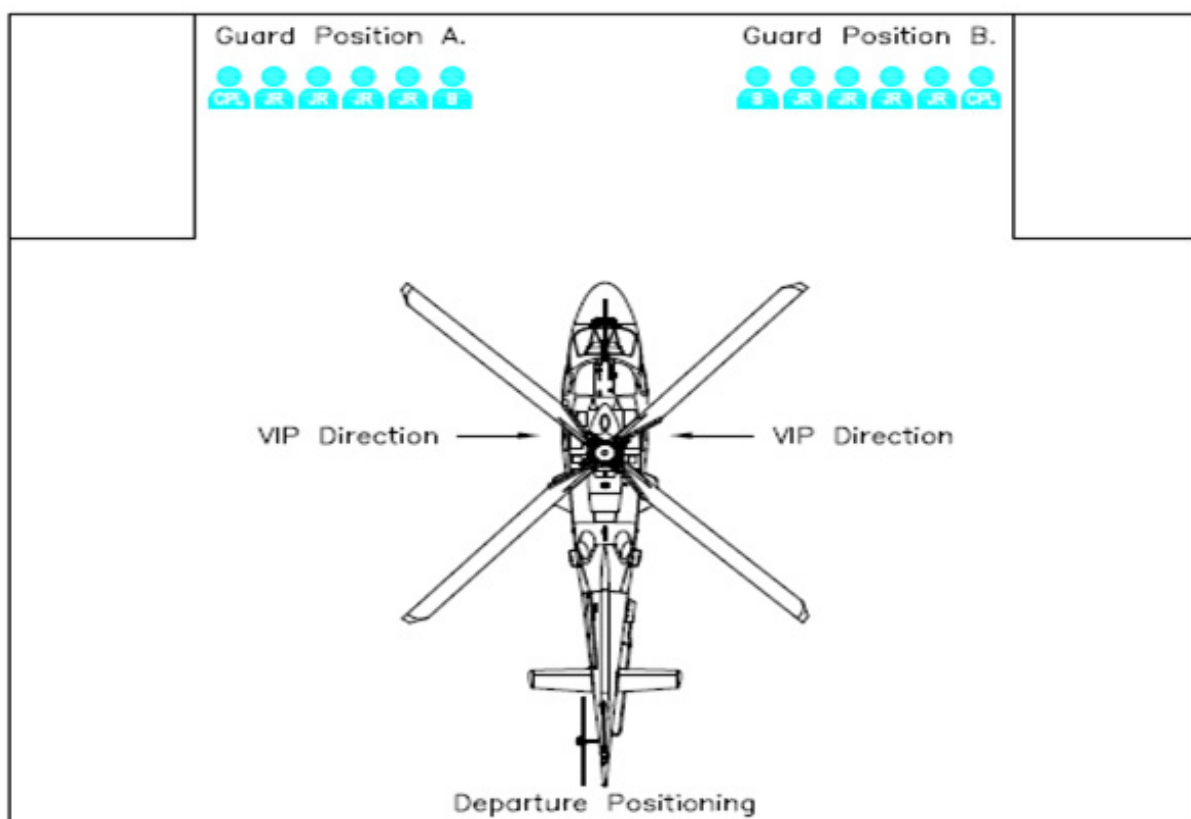

Figure 3-9-7 Layouts for Helicopter Departures

UNCLASSIFIED

Table 3-9-2 Format for Quarter Guard at Aircraft Arrivals and Departures

| Serial | Commander | Command | Action |
|------------------|--|---|--|
| Arrival | | | |
| 1 | Following the welcome at the foot of the aircraft steps the VIP moves to a position and halts centrally in front of the quarter guard. | | |
| 2 | As the VIP approaches | | |
| | CPL | GUARD SHOULDER ARMS | – Guards shoulder arms. |
| 3 | CPL | GUARD GENERAL SALUTE PRESENT – ARMS | – Guards present arms. – Bugler plays the general salute. |
| 4 | At the conclusion of the trumpet call. | | |
| | CPL | GUARD SHOULDER – ARMS | – Guards shoulder arms. – CPL— – marches out two paces from the VIP; – salutes; – reports that the guard is ready for inspection; – accompanies the VIP on the inspection; – on completion of the inspection, escorts the VIP to the vicinity of the base commander or person meeting the VIP; – salutes; and – returns to their position. |
| 5 | CPL | MOVE TO THE LEFT/RIGHT IN FILE – LEFT/RIGHT TURN QUICK – MARCH | – The CPL marches the guard away to be dismissed. |
| Departure | | | |
| 1 | As the VIP vehicle approaches— | | |
| | CPL | GUARD GUARD SHUN | Bugler plays the alert. |
| 2 | The vehicle stops with the VIP door opposite the centre of the guard. As the personage steps out— | | |
| 3 | CPL | GUARD GENERAL SALUTE PRESENT ARMS | – Guards present arms – Bugler plays general salute. |

UNCLASSIFIED

| Table 3-9-2 Format for Quarter Guard at Aircraft Arrivals and Departures (cont.) | | | |
|---|--|---|---|
| Serial | Commander | Command | Action |
| 4 | At the conclusion of the trumpet call— | | |
| | CPL | GUARD SHOULDER – ARMS | <ul style="list-style-type: none"> – CPL— – marches out two paces from the VIP; – salutes; – reports that the guard is ready for inspection; – accompanies the VIP on the inspection; – on completion of the inspection, escorts them to their aircraft; – salutes; and – returns to their position on the right flank. |
| 5 | As the VIP boards their aircraft— | | |
| | CPL | GUARD GENERAL SALUTE PRESENT ARMS | <ul style="list-style-type: none"> – Guard presents arms. – Bugler plays general salute. |
| 6 | When the VIP has boarded their aircraft and bugle call has finished— | | |
| | CPL | GUARD SHOULDER ARMS MOVE TO THE LEFT/RIGHT IN FILE – LEFT/RIGHT TURN QUICK – MARCH | <ul style="list-style-type: none"> – Guard marches away and is dismissed. |

3.9.6 Guest arrival at the Tūrangawaewae

- a. On some occasions guests/VIPs will be welcomed onto a base with a pōwhiri. This can be performed at the Tūrangawaewae so it is customary to form a quarter guard before the welcome.
- b. The guest/VIP is to be sat in the left rear seat of the vehicle.
- c. The procedure for the arrival of VIPs at Tūrangawaewae is shown in Table [3-9-3](#).
- d. The layout for the arrival of VIPs at Tūrangawaewae is shown in Figure [3-9-8](#).

UNCLASSIFIED

Table 3-9-3 Procedure for arrival of VIPs at the Tūrangawaewae

| Serial | Commander | Command | Action |
|--------|--|--|---|
| 1 | When the vehicle has stopped— | | |
| | | | <ul style="list-style-type: none"> – Door opener(s)— – dress forward; – open both the rear doors (only one if the guest/VIP is alone); and – salute. – The guest/VIP is met by a host from the Tūrangawaewae. – The host— – accompanies the guest/VIP to the guard; – halts at a point where the guest/VIP is at least five paces in front of and facing the guard NCO. |
| 2 | The NCO marches forward paces. | | |
| | Guard NCO | GUARD GENERAL/ROYAL SALUTE PRESENT ARMS | <ul style="list-style-type: none"> – The NCO salutes. – The guest/VIP returns the salute (if military and in uniform). – The guest/VIP turns to the right and walks towards Point A. (Refer to Figure 3-9-8.) |
| 3 | When the guest/VIP reaches at Point A— | | |
| | Guard NCO (quietly) | GUARD SHOULDER ARMS STAND – AT – EASE | <ul style="list-style-type: none"> – The guard stands at ease |
| 4 | The guard is dismissed once the guest/VIP has entered the Tūrangawaewae grounds. | | |

UNCLASSIFIED

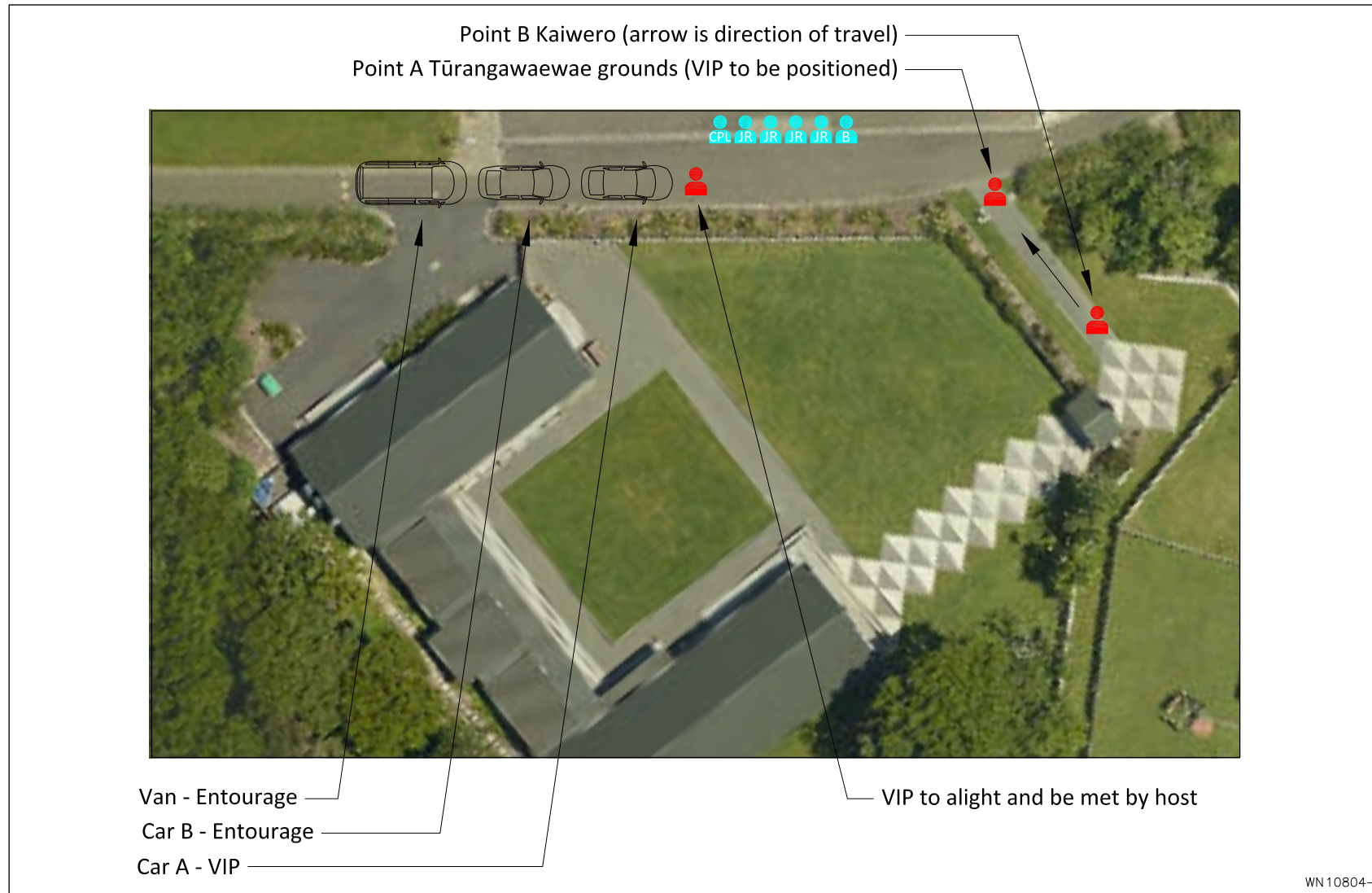

Figure 3-9-8 Layout for Tūrangawaewae visit

Chapter 10 – Route Lining

3.10.1 Preparation

- a. The officer commanding is to allot to units the part of the route that they are to line. Markers are to be sent forward before the arrival of the units to indicate the extent to be occupied by each unit.
- b. In marching to and from the places of assembly, a distance of approximately 300 m is to be maintained between units with bands so as to prevent the sounds of the bands clashing.

3.10.2 Positions

- a. The officer commanding and their adjutant are to be on the flank of the unit that the procession first approaches.
- b. Officers (and Queen's Colour (QC)/Squadron Standards (Sqns), if carried) are to be on the offside of the road from which the procession approaches. flight commanders (FLTCDRs) are to be in the centre of their flights, one pace from the ranks towards the centre of the road. Ranks are normally to be one pace from the ranks towards the centre of the road. Ranks are normally to be one pace from the kerbstone. If a procession is to return, officers (and QC/Sqns) are to take up position on the other rank of their units as soon as the procession has passed for the first time.
- c. Bands are not to be placed where the route is left open by police for traffic. If circumstances permit bands are to be placed opposite the QC/Sqns party, otherwise they are to be conveniently placed where a side street opens onto the route of the procession. The leading rank of the band is to be in line with the personnel lining the route.
- d. Flights are to form up as for flight drill, carrying weapons with bayonets fixed and are to consist of one sergeant (SGT), one corporal (CPL), and 24 other ranks (ORs) commanded by a junior officer.

3.10.3 Taking up positions on the route

- a. Each flight is to be marched in column of route to its allotted position.
 - (1) When approximately 30 paces from the flight markers, the flight is to march onto the crown of the road.
 - (2) The FLTCDR gives the commands—
NO... FLIGHT
FORM TWO – FILES

- (3) When approximately 15 paces from the flight markers, the FLTCDR gives the commands—
- NO ... FLIGHT**
OPEN – OUT
- b. The predetermined interval between ORs lining a route is calculated in paces, and each person is to be briefed to march a set number of paces past the marker before halting. The rear pair of ORs march twice the interval to allow space for the non-commissioned officers (NCOs). After halting, each pair turns to face the centre of the road, turns their heads and eyes toward the marker and takes up their dressing.
- c. The SGT and CPL halt level with the markers.
- d. When the FLTCDR is satisfied that the dressing is correct, they incline their head downwards as a signal to the NCOs to instruct the first pair of ORs to turn their heads and eyes to the front. This movement continued through the flight by pairs of ORs in succession.
- e. When this movement is completed, the NCOs pace out the area covered by their flight, halting after each interval to enable pairs of ORs to adjust their positions. The ORs stand at ease by pairs after the NCOs have adjusted their interval. When this adjustment is completed the NCOs return to their positions between the markers and the first pair of ORs.
- f. The FLTCDR takes up their position in front of the centre of the flight.

3.10.4 Arrival of the procession

- a. The FLTCDR on the flank of the route lining force that the procession first approaches is to receive orders from the parade commander (PCDR) as to when the flight is to be brought to attention in preparation for the compliment to be paid. At that appropriate time, the FLTCDR gives the commands—
- NO... FLIGHT**
NO... FLIGHT
SHUN
- b. Each FLTCDR is to ensure that they do not give their word of command before the preceding flight has completed the movement. Each command is to be preceded by the flight number.
- c. On royal occasions, commands for compliments to be paid are normally to be given when the second division of the Sovereign's Escort is within 20 paces of the nearest flank of the flight paying the compliment.
- d. The FLTCDR gives the commands—
- NO... FLIGHT**
PRESENT – ARMS

- e. As the fourth division of the Sovereign's Escort passes the far flank of their flight, the FLTCDR gives the command—

NO... FLIGHT

SHOULDER – ARMS

- f. The FLTCDR takes up their position in the centre of the road in the centre of the flight, to supervise the reforming of their flight.

3.10.5 Reforming when the procession has passed

- a. NCOs take up position to the rear of the flight and face the direction of the march.
- b. The FLTCDR, having previously briefed the flight on the direction of the march, gives the commands—

NO... FLIGHT

OUTWARDS – TURN

NO... FLIGHT

AT THE HALT

ON NUMBER ONE

QUICK – MARCH

– The leading pair of ORs stand fast.

– The remainder of the flight marches forward and halts individually one arm's distance behind the person in front of them.

- c. The FLTCDR marches to the centre of their flight, halts and gives the commands—

NO ... FLIGHT

INWARDS WHEEL

QUICK – MARCH

FORM THREE – FILES

- d. When the flight is reformed the FLTCDR gives the command—

QUICK – MARCH

Note: On reforming, depending on the width of the road, it is sometimes advisable for a FLTCDR to take up position level with the fourth or fifth file of their flight before stepping off. This will ensure that their flight is able to maintain the correct distance from them.

- e. While flights are closing to the appropriate flank, the band takes up position at the head of the route lining force in preparation to marching off under the orders of the PCDR.

Chapter 11 – Graduation Parade

3.11.1 Preliminary

Key appointments. Various personnel are required for the management of a graduation parade. Figure 3-11-1 identifies symbols that represent the key appointments referred to throughout this chapter and in the accompanying figures to identify positions on the parade ground.









| | |
|--|---|
| Parade commander (PCDR) |  |
| Parade adjutant (PADJ) |  |
| Flight commander (FLTCDR) (graduates) |  |
| Parade warrant officer (PWO) |  |
| Supernumerary officer (graduates) |  |
| Flight sergeant (F/S) |  |
| Supernumerary NCO |  |
| Squadron Standard party (SqSP) |  |

Figure 3-11-1 Graduation Parade Identifiers

UNCLASSIFIED

Section 1 – Outdoor parade procedure

3.11.2 Squadron fall-in

- a. No.1 Flight and No.2 Flight (two ranks) form up in column of twos to the side of the parade ground.
- b. If the Squadron Standard (Sqns) is to be paraded, in normal circumstances No.1 Flight and No.2 Flight will become the escort flights. Both escort flights carry rifles fitted with bayonets. Alternatively, if resources are not available, No.2 Flight may parade unarmed.

3.11.3 Parade form up

The procedure for the form up of a graduation parade is shown in Table [3-11-1](#). The layout of an outdoor graduation parade is shown in Figure [3-11-2](#).

Table 3-11-1 Procedure for Form Up of a Graduation Parade

| Serial | Commander | Command | Action |
|--------|-----------|--|---|
| 1 | | | <ul style="list-style-type: none"> – The PWO marches onto the parade ground. – At the same time the F/Ss move their respective flights into predetermined positions on the parade area, halt and advance. |
| 2 | PWO | PARADE STAND – AT – EASE PARADE PARADE – SHUN PARADE INWARDS/RIGHT – DRESS EYES – FRONT | <ul style="list-style-type: none"> – The PADJ <ul style="list-style-type: none"> – forms up officers off the parade area; – marches the officers out to the PWO where they and halt. – The PWO— <ul style="list-style-type: none"> – salutes; – turns right; and – moves to their position behind No.1 Flight. |
| 3 | PADJ | PARADE STAND – AT – EASE PARADE PARADE – SHUN OFFICERS DRAW SWORDS FALL IN THE OFFICERS | |

UNCLASSIFIED

UNCLASSIFIED

| Table 3-11-1 Procedure for Form Up of a Graduation Parade (cont.) | | | |
|--|-----------------------|---|--|
| Serial | Commander | Command | Action |
| 4 | No.1 Flight commander | OFFICERS RIGHT – TURN QUICK – MARCH | <ul style="list-style-type: none"> – The FLTCDRs take their position in front of the F/Ss. – F/Ss— <ul style="list-style-type: none"> – salute; – left turn; and – take up their positions at the rear of their respective flights. – The supernumerary officers move to their respective positions front or rear of their flights. – The officers await for the inwards turn command from the PADJ. |
| 5 | PADJ | OFFICERS INWARDS – TURN | <ul style="list-style-type: none"> – The supernumerary officers turn left. – The FLTCDRs turn about. – The PADJ— <ul style="list-style-type: none"> – turns about to face the parade commander (PCDR); – salutes; and – moves to their position at the front right hand side of No.1 Flight. |
| 6 | PCDR | PARADE STAND-AT-EASE PARADE PARADE – SHUN PARADE IN OPEN ORDER INWARDS – DRESS | <ul style="list-style-type: none"> – Only the rear rank moves. |
| 7 | PWO | FRONT RANK – STEADY REAR RANK – STEADY | <ul style="list-style-type: none"> – The PWO dresses the flights as required – When the parade is properly dressed and steady, the PWO moves back to their position. |
| 8 | PWO | PARADE STEADY | |
| 9 | PCDR | PARADE EYES – FRONT PARADE STAND – AT - EASE | <ul style="list-style-type: none"> – The orator completes a ‘Welcome’ to all gathered while waiting for the arrival of the reviewing officer and VIPs. |

UNCLASSIFIED

UNCLASSIFIED

NZAP 2.4 Manual of Ceremonial and Drill
 Part 3 – Ceremonial Drill
 Chapter 11 – Graduation Parade

Version 6.00
 13 June 2023

3.11.4 Arrival of the reviewing officer/VIP(s)

The procedure for the arrival of the reviewing officer/VIP(s) at a graduation parade is shown in Table [3-11-2](#).

Table 3-11-2 Arrival of the Reviewing Officer/VIP(s) at a Graduation Parade

| Serial | Commander | Command | Action |
|--------|--|---|--|
| 1 | As the reviewing officer/VIP's vehicle approaches— PCDR | PARADE PARADE – SHUN | <ul style="list-style-type: none"> – The reviewing officer/VIP (and their escort) alight the vehicle and take their position on the dais. – The escort officer remains to the side of the dais. |
| 2 | PCDR | PARADE GENERAL SALUTE PRESENT – ARMS | <ul style="list-style-type: none"> – If music is available, general salute music is played. |
| 3 | PCDR | PARADE SHOULDER – ARMS | <ul style="list-style-type: none"> – The PCDR approaches dais, salutes and invites the reviewing officer /VIP to inspect the parade. <p>Note: The escort officer may accompany the reviewing officer/VIP but this will depend on the location of the parade. If the escort officer does not accompany the reviewing officer/VIP, the escort officer remains at the side of the dais.</p> <ul style="list-style-type: none"> – Once the inspection is complete, the PCDR escorts the reviewing officer/ VIP back to the dais and requests permission to carry on with parade. – The PCDR salutes, makes a right turn, marches back into position. |
| 4 | PCDR | PARADE GENERAL SALUTE PRESENT – ARMS | <ul style="list-style-type: none"> – If music is available, general salute music played. |
| 5 | PCDR | PARADE SHOULDER – ARMS | <ul style="list-style-type: none"> – The reviewing officer/VIP remains on dais. – The escort officer takes a seat. – The PCDR takes up a position at the side of the dais, facing the parade ready for the presentation. |

UNCLASSIFIED

UNCLASSIFIED

NZAP 2.4 Manual of Ceremonial and Drill
 Part 3 – Ceremonial Drill
 Chapter 11 – Graduation Parade

Version 6.00
 13 June 2023

3.11.5 March on the Squadron Standard

The procedure for when the SqnS is to be paraded at a graduation parade is shown in Table [3-11-3](#).

Table 3-11-3 March on of Squadron Standard for Graduation Parade

| Serial | Commander | Command | Action |
|--------|-----------|--|---|
| 1 | PCDR | MARCH ON THE SQUADRON STANDARD | |
| 2 | SqnSB | STANDARD PARTY BY THE CENTRE QUICK | – The SqnSP marches on to the sound of the third drum beat. |
| 3 | PCDR | PARADE GENERAL SALUTE PRESENT – ARMS | – If music is available, general salute music is played, followed immediately by Point of War. – As the SqnS is marched into position between the flights, the SqnS W/O automatically goes into 'open-order' position. |
| 4 | PCDR | PARADE SHOULDER – ARMS PARADE STAND – AT – EASE | |

3.11.6 Presentation of wings and awards

The procedure for the presentation of wings and awards at a graduation parade is shown in Table [3-11-4](#).

Table 3-11-4 Presentation of Wings and Awards at a Graduation Parade

| Serial | Commander | Command | Action |
|--------|-----------|--|--|
| 1 | | Before the presentation— | |
| | PCDR | PCDR GRADUATES WILL RETURN SWORDS RETURN – SWORDS | – Graduates – return their swords; then – march smartly into position in front of dais; – halt; and – remain at attention. |
| 2 | PCDR | GRADUATES WITHOUT INTERVALS INWARDS DRESS | – Graduates take dressing from centre. |
| 3 | PCDR | EYES – FRONT GRADUATES WILL REMOVE GLOVES REMOVE – GLOVES | – Graduates remove their right glove only and place it in their pocket. |

UNCLASSIFIED

UNCLASSIFIED

| Table 3-11-4 Presentation of Wings and Awards at a Graduation Parade (cont.) | | | |
|---|--|---|--|
| Serial | Commander | Command | Action |
| 4 | PCDR | PARADE STAND – AT – EASE | |
| 5 | The escort officer invites the reviewing officer/VIP to move in front of the dais for the presentations. | | |
| 6 | The orator announces the presentations— <ul style="list-style-type: none"> – Presentation ofto – Presentation ofto | | |
| 7 | <ul style="list-style-type: none"> – After the presentations, the PCDR moves to a position in front of the reviewing officer/VIP and asks if they would like to address the parade. – The PCDR— <ul style="list-style-type: none"> – salutes; and – moves back to the side of the dais. – The reviewing officer/VIP moves forward to the microphone and delivers their speech. – When the reviewing officer/VIP has completed their speech is completed, the PCDR invites the reviewing officer/VIP to be seated. | | |
| 8 | <ul style="list-style-type: none"> – The PCDR invites the padre/chaplain to pray— CHAPLAIN PRAYERS PLEASE – The padre/chaplain— <ul style="list-style-type: none"> – moves forward to the microphone; – delivers the prayers; and – when finished, returns to their seat. | | |
| 9 | PCDR | GRADUATES WILL REPLACE GLOVES REPLACE – GLOVES | <ul style="list-style-type: none"> – Graduates replace their gloves. – The PCDR returns to their original parade position beside the dais. |
| 10 | PCDR | PARADE PARADE – SHUN | <ul style="list-style-type: none"> – The parade comes to attention. |

UNCLASSIFIED

UNCLASSIFIED

NZAP 2.4 Manual of Ceremonial and Drill
 Part 3 – Ceremonial Drill
 Chapter 11 – Graduation Parade

Version 6.00
 13 June 2023

3.11.7 Flypast

- a. It is RNZAF tradition for graduation parades to include a flypast.
- b. The procedure for the flypast is shown in Table [3-11-5](#).

Table 3-11-5 Procedure for the Flypast at a Graduation Parade

| Serial | Commander | Command | Action |
|--------|--|--|--|
| 1 | PCDR | TIME FOR THE FLYPAST TO COMMENCE | |
| 2 | PCDR | FALL IN THE GRADUATES GRADUATES RIGHT – TURN QUICK – MARCH | – Graduates return to their original positions. |
| 3 | PCDR | GRADUATES WILL DRAW SWORDS DRAW – SWORDS PARADE INWARDS – DRESS | – Graduates draw swords and inwards dress. |
| 4 | PCDR | EYES-FRONT | Note: This command is for the graduates only. |
| 5 | The aircraft fly past. | | |
| 6 | On completion of the flypast, the orator invites the reviewing officer/VIP and invited guests to view a flying display at a time that will be confirmed. | | |

3.11.8 Parade dispersal

- a. The procedure for the graduation parade dispersal is shown in Table [3-11-6](#).

Table 3-11-6 Procedure for the Dispersal of a Graduation Parade

| Serial | Commander | Command | Action |
|---|--|---|---|
| Departure of the reviewing officer/VIP— | | | |
| 1 | | | <ul style="list-style-type: none"> – The escort officer— <ul style="list-style-type: none"> – invites the reviewing officer/VIP to move to the dais; and – takes their position to the side. – The vehicle(s) approach the dais. |
| | PCDR | GENERAL SALUTE PRESENT – ARMS | <ul style="list-style-type: none"> – The reviewing officer/VIP— <ul style="list-style-type: none"> – returns salute; and – with the escort officer, enters the vehicle and departs. |
| 2 | When the reviewing officer/VIP are clear of the parade area— | | |
| | PCDR | PARADE SHOULDER ARMS CLOSE ORDER – MARCH | |

UNCLASSIFIED

UNCLASSIFIED

NZAP 2.4 Manual of Ceremonial and Drill
 Part 3 – Ceremonial Drill
 Chapter 11 – Graduation Parade

Version 6.00
 13 June 2023

| Table 3-11-6 Procedure for the Dispersal of a Graduation Parade (cont.) | | | |
|--|--|--|---|
| Serial | Commander | Command | Action |
| 3 | March off the SqnS. – All personnel stand. – Personnel in uniform salute as the SqnS crosses in front of them and departs. | | |
| | PCDR | PARADE GENERAL SALUTE PRESENT – ARMS | – If music is available, general salute music is played, followed immediately by Point of War. |
| | At the same time— | | |
| | SqnS bearer | SQN STANDARD PARTY BY THE CENTRE QUICK – MARCH | |
| 4 | When the SqnS is clear of the parade area— | | |
| | PCDR | PARADE SHOULDER – ARMS PARADE STAND – AT – EASE | – The parade stands at ease while waiting for the BCDR's vehicle to arrive. |
| 5 | As the BCDR's vehicle arrives— | | |
| | PCDR | PARADE PARADE – SHUN | – The BCDR moves to dais where they receive a sword salute for the PCDR. – The BCDR enters their vehicle and departs. |
| 6 | When the vehicle is clear of the parade area, the PCDR instructs the PADJ to take over the parade. | | |
| | PCDR | PARADE ADJUTANT TAKE COMMAND OF THE PARADE | – The PCDR does a left turn and marches off. |
| 7 | When the PCDR is clear of the parade area— | | |
| | PADJ | FALL OUT THE OFFICERS OFFICERS QUICK – MARCH | – Officers— – march off the parade ground; – halt; and – form a semi-circle around the No.1 Flight commander. – At the same time F/Ss move to the vacated FLTCDR positions in front of their flights. |
| 8 | No.1 FLTCDR | OFFICERS WILL RETURN SWORDS RETURN – SWORDS TO YOUR DUTIES DIS – MISS | – Officers— – return their swords; and – dismiss. |
| 9 | PADJ | PARADE WARRANT OFFICER THANK YOU TAKE COMMAND OF THE PARADE | – PADJ salutes the PWO. – The PWO— – acknowledges the request; and – salutes. – The PADJ does a right turn and marches off. |

UNCLASSIFIED

UNCLASSIFIED

| Table 3-11-6 Procedure for the Dispersal of a Graduation Parade (cont.) | | | |
|--|--|---|---|
| Serial | Commander | Command | Action |
| 10 | When the PADJ is clear of the parade area— | | |
| | PWO | PARADE WILL MOVE TO THE LEFT IN COLUMN OF TWOS LEFT – TURN BY THE RIGHT QUICK – MARCH HALT PARADE WILL ADVANCE RIGHT – TURN STAND – AT – EASE PARADE PARADE – SHUN F/SS CARRY ON AND MARCH YOUR FLIGHTS BACK TO THE ARMOURY | – F/Ss march their respective flights back to the armoury to— – return weapons; and – be dismissed. |

Section 2 – Wet weather alternative

3.11.9 Parade format

- a. Two flights consisting of 20 personnel in each are to be formed up in two ranks at the predetermined assembly area.
- b. Supernumerary NCOs are to be at the front of each flight.
- c. The two flights are to be unarmed when parading indoors.
- d. The format for an indoor graduation parade is shown in Figure [3-11-3](#).

3.11.10 Parade form up

The procedure for the form up of an indoor graduation parade is shown in Table [3-11-7](#).

3.11.11 March on the Squadron Standard

The procedure for when the SqnS is to be paraded during an indoor graduation parade is the same as for the outdoor graduation parade, refer to paragraph [3.11.5](#) and Table [3-11-3](#).

3.11.12 Arrival of the reviewing officer/VIP

The procedure for the arrival of the reviewing officer/VIP is as for the arrival of the reviewing officer/VIP at an outdoor graduation parade, refer to paragraph [3.11.4](#) and Table [3-11-2](#), except that—

- (1) the reviewing officer/VIP arrives and departs on foot instead of in a vehicle; and
- (2) the reviewing officer/VIP is invited to inspect only the front rank of the parade.

UNCLASSIFIED

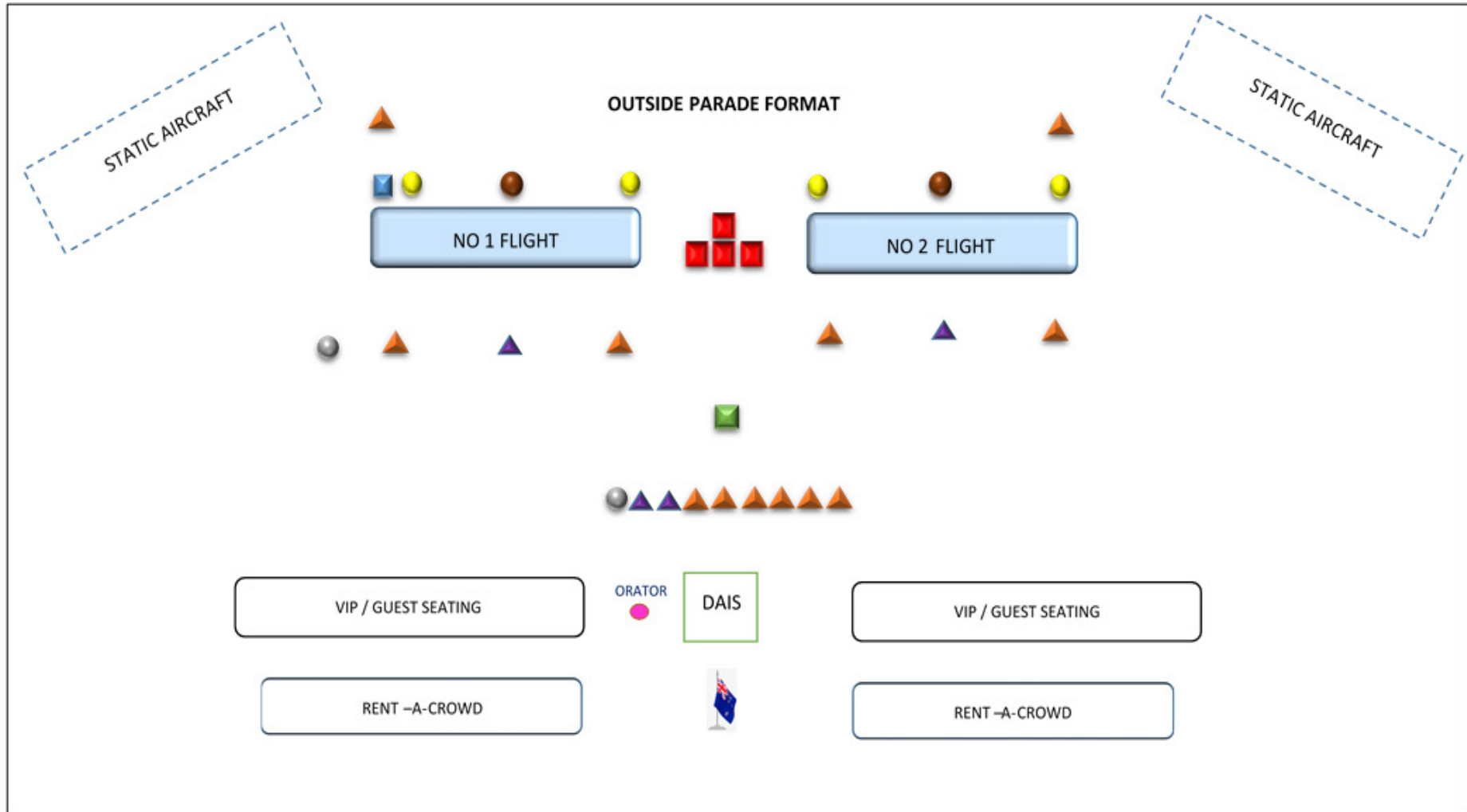

Figure 3-11-2 Graduation Parade Outdoor Format

UNCLASSIFIED

Table 3-11-7 Forming up an Indoor Graduation Parade

| Serial | Commander | Command | Action |
|--------|--|---|---|
| 1 | PWO | PARADE PARADE – SHUN PARADE INWARDS – DRESS EYES – FRONT | |
| 2 | The PADJ forms up officers off the parade ground. The PADJ marches the officers out to the PWO. | | |
| 3 | PADJ | OFFICERS WILL DRAW SWORDS DRAW SWORDS | <ul style="list-style-type: none"> - The PWO— - salutes; - turns to the right; and - marches to their position behind No.1 Flight. |
| 4 | Once the PWO is in position— | | |
| | PADJ | PARADE STAND – AT – EASE PARADE PARADE – SHUN FALL IN THE OFFICERS | <ul style="list-style-type: none"> - The FLTCDRs march out to face the supernumerary NCOs. - supernumerary NCOs— - salute; and - take up position at the rear of the flights. |
| 5 | No.1 FLTCDR | OFFICERS RIGHT – TURN QUICK – MARCH | |
| 6 | PADJ | FLIGHT COMMANDERS ABOUT – TURN | <ul style="list-style-type: none"> - At the same time the PADJ— - turns about; and - hands over to the PCDR. |
| 7 | PCDR | PARADE STAND – AT – EASE | |

3.11.13 Presentation of wings and awards

The procedure for the presentation of wings and awards at an indoor graduation parade is as for the presentation of wings and awards at an outdoor graduation parade, refer to paragraph [3.11.6](#) and Table [3-11-4](#).

3.11.14 Flypast

The procedure for the flypast at an indoor graduation parade is as for the flypast at an outdoor graduation parade, refer to paragraph [3.11.7](#) and Table [3-11-5](#).

UNCLASSIFIED

3.11.15 Parade dispersal

The procedure for the dispersal of the indoor graduation parade is as for the dispersal of the outdoor graduation parade as shown in Table [3-11-6](#), except that—

- (1) the reviewing officer/VIPs leaves on foot instead of in a vehicle (Serial 1); and
- (2) for Serial 12 the PWO gives the command—

PARADE

TO YOUR DUTIES

DIS – MIS

- The F/Ss form up their flights outside and march to the armoury to—
 - return weapons, if the flights are armed; and
 - be dismissed.

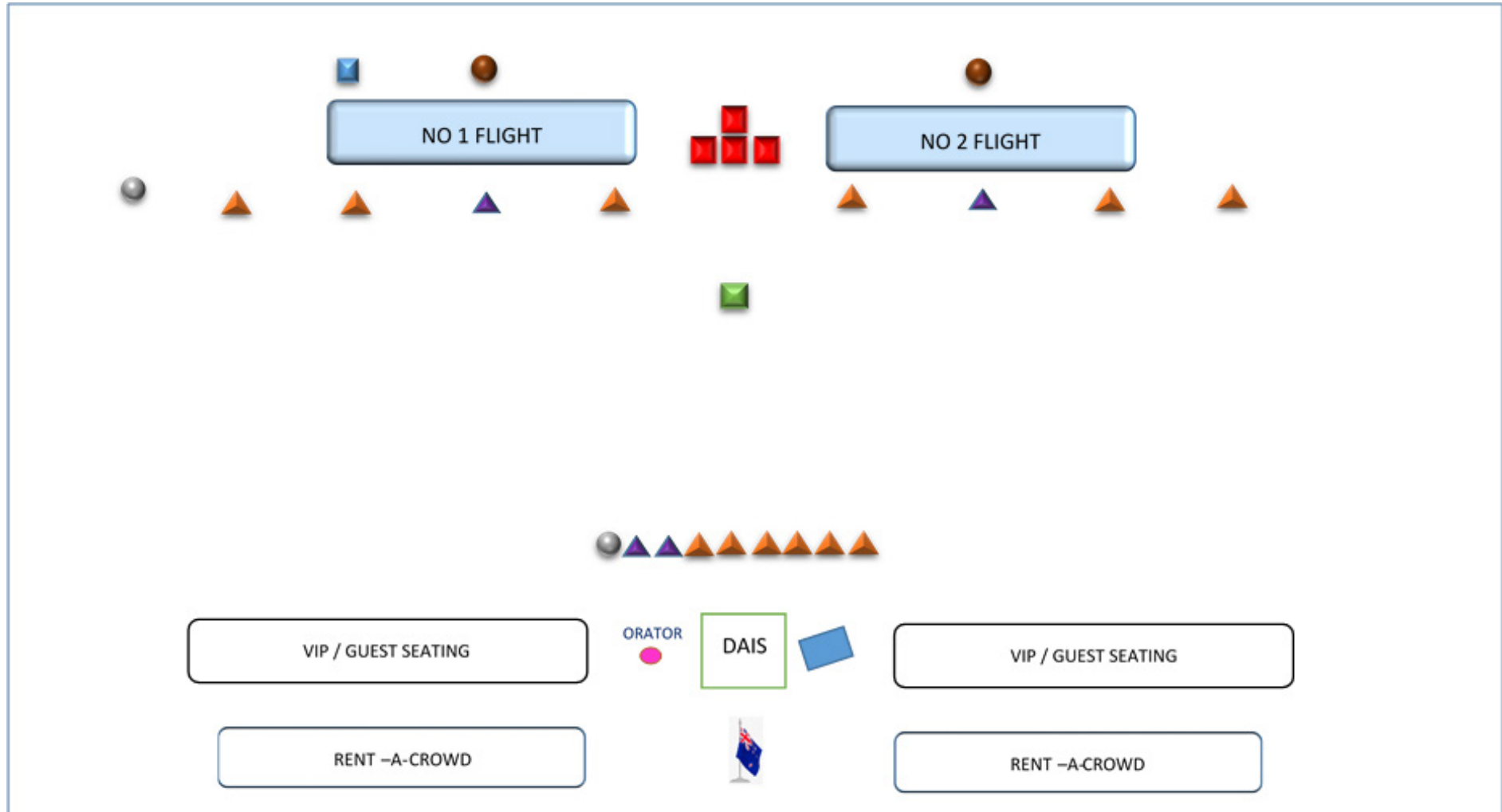

Figure 3-11-3 Graduation Parade Wet Weather Format

Chapter 12 – Change of Command Parade with the Sovereign’s Colour

Section 1 – Outdoor parade procedure

3.12.1 Parade format

- a. **General.** The parade—
- (1) consists of—
 - (a) an escort squadron; and
 - (b) up to two support squadrons.
 - (2) The parade will take the format of ceremonial review of a squadron.
- b. **Support squadrons**
- (1) The support squadron will be staffed in accordance with details set out as an annex attached to the admin instruction for the particular parade.
 - (2) At a predetermined time, the squadron warrant officer(s) (SWOs) form up their squadrons at their respective positions on the parade ground.
 - (3) SWOs hand over the support squadrons to support squadron commanders (SSqnCDRs).
 - (4) Support squadrons form up in line as for squadron parades (refer to Part 2, [Chapter 4](#)).
 - (5) SSqnCDRs bring their squadrons to attention when the escort squadron marches on to the parade ground.
 - (6) Support squadron(s) come under of the command of the parade commander (PCDR) when the command ‘Parade’ is used.
- c. **Escort squadron.** The escort squadron consists of two armed flights with bayonets fitted. It is to form up at a predetermined location as a squadron in line. Officers are to have their swords drawn.

Note: In normal circumstances No.1 and No.2 escort flights are to be armed with rifles fitted with bayonets. Alternatively, if resources are not available, the two flights may parade unarmed.

3.12.2 Parade form up

- a. The procedure for the form up of a change of command parade with Queen’s Colour (QC) is shown in Table [3-12-1](#).
- b. The PCDR is prepositioned by the dais.

UNCLASSIFIED

NZAP 2.4 Manual of Ceremonial and Drill

Version 6.00

Part 3 – Ceremonial Drill

13 June 2023

Chapter 12 – Change of Command Parade with the Sovereign's Colour

Table 3-12-1 Form Up of an Outdoor Change of Command Parade with Queen's Colour

| Serial | Commander | Command | Action |
|---------------------------------|---------------------------------|---|---|
| 1 | | The ESWO takes up a position six paces in the front centre of the squadron. | |
| 2 | PWO | ESCORT SQUADRON ESCORT SQUADRON – SHUN | – The PWO hands the escort squadron over to the PADJ. |
| 3 | PADJ | ESCORT SQUADRON STAND AT – EASE ESCORT SQUADRON ESCORT SQUADRON – SHUN FALL IN THE OFFICERS | – Officers fall in. |
| March on escort squadron | | | |
| 4 | PADJ | ESCORT SQUADRON MOVE TO RIGHT IN THREE RIGHT – TURN BY THE LEFT | – Escort squadron steps off with a three beat drum roll. – As the escort squadron is marching on, the support squadrons are brought to attention. |
| 5 | PADJ | ESCORT SQUADRON HALT ESCORT SQUADRON WILL ADVANCE LEFT TURN OFFICERS TAKE POST IN REVIEW ORDER OUTWARDS – TURN QUICK – MARCH OFFICERS LEFT – TURN ESCORT SQUADRON IN OPEN ORDER – RIGHT DRESS | |
| 6 | When PWO confirms the dressing— | | |
| | PADJ | EYES FRONT | – ESADJ hands the escort squadron over to the PCDR. |
| 7 | PDCR | PARADE STAND AT – EASE PARADE PARADE – SHUN | |
| March on the Squadron Standards | | | |
| 8 | PCDR | MARCH ON THE SQUADRON STANDARDS PARADE GENERAL SALUTE PRESENT – ARMS | – On the last movement of the 'Present', the band plays 'Point of War'. – Then the drum element of the band plays a 2 x 3 beat roll. – The SqnSPs then step off as the band plays the first beat of the RNZAF March. – The band continues to play the RNZAF March as the SqnSPs march into position, equally spaced between escort squadron flights. |

UNCLASSIFIED

UNCLASSIFIED

NZAP 2.4 Manual of Ceremonial and Drill

Version 6.00

Part 3 – Ceremonial Drill

13 June 2023

Chapter 12 – Change of Command Parade with the Sovereign's Colour

| Table 3-12-1 Form Up of an Outdoor Change of Command Parade with Queen's Colour (cont.) | | | |
|--|--|--|---|
| Serial | Commander | Command | Action |
| 9 | When the SqnSPs are in the position— | | |
| | PCDR | PARADE SHOULDER ARMS PARADE STAND AT – EASE | |
| Arrival of VIPs | | | |
| 10 | As the ACC (or equivalent VIP) arrives— | | |
| | PCDR | PARADE PARADE – SHUN | <ul style="list-style-type: none"> – PCDR pays compliments to the VIP. – The VIP takes their seat. |
| 11 | The parade remains at attention until all VIPs have arrived. | | |
| 12 | When CAF (or their representative) has arrived and taken their position on the dais— | | |
| | PCDR | PARADE GENERAL SALUTE – PRESENT ARMS PARADE SHOULDER ARMS STAND AT – EASE | |
| 13 | As the outgoing BCDR arrives— | | |
| | PCDR | PARADE PARADE – SHUN | |
| 14 | When the outgoing BCDR is in position on the dais— | | |
| | PCDR | PARADE GENERAL SALUTE – PRESENT ARMS | <ul style="list-style-type: none"> – Band plays appropriate music. – Flypast, if scheduled. |
| 15 | When the musical honour concludes— | | |
| | PCDR | PARADE SHOULDER ARMS | <ul style="list-style-type: none"> – PCDR <ul style="list-style-type: none"> – approaches the dais; and – gives a full salute. |
| 16 | The PCDR invites outgoing BCDR to inspect the parade. | | |
| | PCDR | SIR/MA'AM PARADE READY FOR INSPECTION | <ul style="list-style-type: none"> – The PCDR moves on the right of outgoing BCDR to the point where the inspection begins. – Inspection is of front rank and band only. – During the inspection the PCDR leads the outgoing BCDR on the side farthest from the parade, taking care not to move between the BCDR and the aviators being inspected. – During the inspection, the receiving and retiring QCPs are prepositioned facing the parade, at the extreme left/right dependent upon location. |

UNCLASSIFIED

UNCLASSIFIED

NZAP 2.4 Manual of Ceremonial and Drill

Version 6.00

Part 3 – Ceremonial Drill

13 June 2023

Chapter 12 – Change of Command Parade with the Sovereign’s Colour

| Table 3-12-1 Form Up of an Outdoor Change of Command Parade with Queen’s Colour (cont.) | | | |
|--|--|--|--|
| Serial | Commander | Command | Action |
| 17 | After the inspection, the PCDR accompanies outgoing BCDR back to the dais and— a. invites the outgoing BCDR to address the parade; and b. requests permission to carry on. | | |
| 18 | The PCDR moves back to their position— | | |
| | PCDR | PARADE STAND AT EASE | – The outgoing BCDR addresses the parade. |
| Arrival of the incoming BCDR | | | |
| 19 | When the incoming BCDR alights from their vehicle they are met by a MCG representative. At the same time— | | |
| | PCDR | PARADE PARADE – SHUN | – A member of the MCG escorts the incoming BCDR and their whānau as the kaikaranga, wero, karanga and haka pōwhiri are conducted. – On completion of the Māori formalities, the incoming BCDR is met by CAF and they both mount the dais. – The MCG escort takes their seat. |
| Command appointment ceremony | | | |
| 20 | The outgoing BCDR hands over the artefacts to the incoming BCDR. CAF and the outgoing BCDR take their seats. The incoming BCDR takes their place on the dais. | | |
| 21 | PCDR | PARADE GENERAL SALUTE PRESENT – ARMS PARADE SHOULDER – ARMS | – The PCDR approaches the dais and requests start of the ceremony for the handing over of the QC. |

UNCLASSIFIED

3.12.3 Handover of the Queen’s Colour

The procedure for the handover of the QC is shown in Table [3-12-2](#).

Table 3-12-2 Handover of the Queen’s Colour

| Serial | Commander | Command | Action |
|--------|---|---|--|
| 1 | PCDR | RECEIVING AND RETIRING COLOUR PARTIES TAKE POST | <ul style="list-style-type: none"> – The receiving QCP, under the orders of the receiving QCB marches out to a position 15 paces from the saluting base facing left. – The retiring QCP, under the orders of the retiring QCB marches out to a position seven paces from the receiving QCP and halts facing the receiving QCP. – Movements of both QCPs are to be coordinated (using drum beats). – The QCO takes up their position independently. |
| 2 | PCDR | UNCASE THE QUEEN’S COLOUR PARADE GENERAL SALUTE PRESENT – ARMS | <ul style="list-style-type: none"> – The QC is uncased as per paragraph _____ |
| 3 | PCDR | PARADE SHOULDER – ARMS | <ul style="list-style-type: none"> – The Queen’s Colour escorts— <ul style="list-style-type: none"> – turn to face inwards; and – assume the position of attention. |
| 4 | PCDR | HAND OVER THE QUEEN’S COLOUR | <ul style="list-style-type: none"> – QCPs carry out the formal handover procedure as detailed in Part 4, Chapter 4. |
| 5 | The retiring QCB draws their sword and salutes. | | |
| | PCDR | MARCH ON THE QUEEN’S COLOUR PARADE GENERAL SALUTE PRESENT – ARMS | <ul style="list-style-type: none"> – The receiving QCB brings the QC to the ‘carry’ on the command ‘PRESENT ARMS’. – The band plays ‘Point of War’ on the command ‘PRESENT ARMS’. |
| 6 | At the conclusion of the playing of ‘Point of War’— | | |
| | Receiving QCB | COLOUR PARTY TO THE MARCH RIGHT FIXED PIVOT WHEEL | <ul style="list-style-type: none"> – Through a series of left fixed pivot wheels, the receiving QCB moves to their predetermined position. |
| 7 | When the receiving QCP is clear of the retiring QCP, under the command of the QCB, the retiring QCP— <ul style="list-style-type: none"> – shoulder arms; – step off; and – march directly off the parade ground along a predetermined route. | | |
| 8 | When the receiving QCP is in position between the flights. | | |
| | PCDR | PARADE SHOULDER – ARMS | |

3.12.4 Parading the Queens Colour

The procedure for parading the QC is shown in Table [3-12-3](#).

Table 3-12-3 Procedure for Parading the Queen’s Colour

| Serial | Commander | Command | Action |
|--------|------------------------------|---|--|
| 1 | PCDR | PARADE THE QUEEN’S COLOUR COLOUR PARTY TAKE POST | – The QCP takes up position at the left flank of the escort squadron. |
| 2 | QCB | ESCORTS TAKE POST | |
| 3 | When the QCP is in position— | | |
| | PCDR | ESCORT SQUADRON GENERAL SALUTE PRESENT – ARMS | – Officer(s) of the support squadron(s) pay complements on this command. |
| 4 | QCB | COLOUR PARTY BY THE LEFT SLOW – MARCH | <ul style="list-style-type: none"> – The band plays a suitable march. – The QCP slow marches through the line of flights. – On completion of this march, the QCP returns to centre of escort squadron |
| 5 | PCDR | ESCORT SQUADRON SHOULDER – ARMS | – Officer(s) of the support squadron(s) pay complements on this command. |

3.12.5 Advance in review order

The procedure for the advance in review order is shown in Table [3-12-4](#).

Table 3-12-4 Advance in Review Order During Parading the Queen’s Colour

| Serial | Commander | Command | Action |
|--------|-----------|--|--------|
| 1 | PCDR | ESCORT SQUADRON CLOSE ORDER – MARCH RIGHT – DRESS EYES – FRONT ESCORT SQUADRON WILL ADVANCE IN REVIEW ORDER BY THE CENTRE QUICK – MARCH PARADE GENERAL SALUTE PRESENT – ARMS PARADE SHOULDER – ARMS | |

UNCLASSIFIED

Table 3-12-4 Advance in Review Order During Parading the Queen’s Colour (cont.)

| Serial | Commander | Command | Action |
|--------|--|--|--|
| 2 | Incoming BCDR and CAF addresses, and prayers | | |
| | The PCDR approaches the dais and requests— a. permission to stand the parade at ease; and b. the incoming BCDR and CAF to address the parade. The PCDR salutes and resumes their position in the guard. | | |
| 3 | PCDR | PARADE STAND AT EASE | – Incoming BCDR address. – CAF address. |
| 4 | On completion of CAF’s address, the PCDR invites the padre/chaplain to conduct prayers. | | |
| | PCDR | PADRE/CHAPLAIN PRAYERS PLEASE | – The padre/chaplain conducts prayers. |

3.12.6 VIP departures

- a. The procedure for the departure of very important person(s) (VIP(s)) is shown in [Table 3-12-5](#).
- b. The order of departure is as follows—
 - (1) CAF (Chief of Air Force).
 - (2) ACC (Air Component Commander).
 - (3) New BCDR (Base Commander).

Table 3-12-5 Departure of VIPs from Parading the Queen’s Colour

| Serial | Commander | Command | Action |
|--------|-----------------------------|--|--------|
| 1 | As each VIP departs— | | |
| | PCDR | PARADE PARADE – SHUN PARADE GENERAL SALUTE PRESENT ARMS | |
| 2 | When each VIP has departed— | | |
| | PCDR | PARADE SHOULDER ARMS | |

UNCLASSIFIED

UNCLASSIFIED

3.12.7 March off the Queens Colour and Squadron Standards

The procedure for marching off the Queen’s Colour is shown in Table [3-12-6](#).

Table 3-12-6 Procedure for Marching off the Queen’s Colour

| Serial | Commander | Command | Action |
|--------|---|---|---|
| 1 | When all of the VIPs have departed— | | |
| | PCDR | MARCH OFF THE QUEENS COLOUR PARADE GENERAL SALUTE PRESENT – ARMS | – If/when ‘Point of War’ is played, the music begins on the last movement of the ‘Present’. |
| 2 | When the QCP has cleared the parade area— | | |
| | PCDR | PARADE SHOULDER ARMS MARCH OFF THE SQUADRON STANDARDS PARADE GENERAL SALUTE PRESENT ARMS | – If/when ‘Point of War’ is played, the music begins on the last movement of the ‘Present’. |
| 3 | When the SqnSPs have cleared the parade area— | | |
| | PCDR | PARADE SHOULDER ARMS | |

3.12.8 Escort squadron march off/dismiss

The procedure for escort squadron march off/dismiss is shown in Table [3-12-7](#).

Table 3-12-7 Procedure for March off/Dismiss of Escort Squadron

| Serial | Commander | Command | Action |
|--------|-----------|---|---|
| 1 | PCDR | OFFICERS WILL TAKE POST LEFT – TURN QUICK – MARCH OFFICERS INWARDS – TURN | – PCDR hands over the parade to the PADJ. – PCDR marches off. |
| 2 | PADJ | ESCORT SQUADRON MOVE TO THE LEFT IN THREES LEFT – TURN BY THE RIGHT QUICK MARCH | |
| 3 | PADJ | ESCORT SQUADRON HALT ESCORT SQUADRON WILL ADVANCE RIGHT – TURN FALL OUT THE OFFICERS | – Officers conduct fall out procedure as described in paragraph 3.11.8(11). |

UNCLASSIFIED

| Table 3-12-7 Procedure for March off/Dismiss of Escort Squadron (cont.) | | | |
|--|--|---------|--------|
| Serial | Commander | Command | Action |
| 4 | PADJ calls for the SWO, who then takes over command of the squadron. | | |
| 5 | The SWO orders the F/Ss to take command of their respective flights. | | |
| <p>Note: F/Ss are instructed to return weapons to the armoury. Weapons return is to be supervised by parade senior non-commissioned officers (SNCOs). Personnel may then attend the afternoon tea and conduct the haka (time to be advised). When the escort squadron has departed the parade ground, SSqnCDRs dismiss their squadrons.</p> | | | |

Section 2 – Indoor parade procedure

3.12.9 Parade format

- a. **General.** The parade is to consist of an escort squadron of one armed flight and up to two support squadrons. The parade takes the format of ceremonial review of a squadron.
- b. **Support squadrons.** At a predetermined time, support SWOs form up their squadrons at their respective predetermined assembly locations. The SWO then hands over the support squadrons to squadron commanders (PCDRs). Support squadrons form up in line as for squadron parades. (Refer to Part 2, [Chapter 4](#)).
- c. **Escort squadron.** The escort squadron forms up with weapons with bayonets fitted. Officers are to have swords drawn.

3.12.10 Parade procedures

- a. The procedure for the form up of the parade for an indoor format is as shown in paragraph [3.12.2](#) and Table [3-12-1](#) for the outdoor format of the parade except that—
 - (1) Serials 4-7 (march on escort squadron) are omitted. Instead the escort squadron instead forms up in place along with the rest of the parade.
 - (2) The inspection at Serial 16 is of the Squadron Standard party (SqnSP) and the front rank of the parade only.
 - (3) The arrival of the incoming BCDR at Serial 19 is on foot rather than by vehicle.
- b. The procedure for the handover of the QC for an indoor format is as shown in paragraph [3.12.3](#) and Table [3-12-2](#) for the outdoor format of the parade.
- c. The procedure for parading the QC for an indoor format is as shown in paragraph [3.12.4](#) and Table [3-12-3](#) for the outdoor format of the parade.
- d. The procedure for the incoming BCDR and CAF addresses and prayers for an indoor format is as shown in paragraph [3.12.5](#) and Table [3-12-4](#), Serials 2–4 for the outdoor format of the parade.
- e. The procedure for departure of the VIPs from a parade is as shown in paragraph [3.12.6](#) and Table [3-12-5](#) for the outdoor format of the parade.

- f. The procedure for the march off of the QC and SqnSs from an indoor parade is as shown in paragraph [3.12.7](#) and Table [3-12-6](#) for the outdoor format of the parade.
- g. The procedure for the escort squadron march off/dismiss is as follows—
- (1) The PCDR gives the following command—
FALL OUT THE OFFICERS
 - Officers conduct fall out procedure as described in Table [3-11-6](#), serials 7 and 8.
 - (2) The PCDR calls for the support SWO, who then takes over command of the squadron.
 - (3) The PCDR marches off.

Note: F/Ss are instructed to return weapons to the armoury. Weapon return is to be supervised by parade SNCOs. When the escort squadron has departed, support PCDRs dismiss their squadrons.

PART 4 – QUEEN'S COLOUR AND SQUADRON STANDARD CEREMONIAL DRILL

Note: The ceremonial drills in this part are for guidance purposes. They may be adjusted to fit different locations and to serve the specific requirements of different ceremonial events.

Contents

| | |
|---|------------|
| Chapter 1 – The Royal New Zealand Air Force Ensign | 4-1 |
| 4.1.1 Royal New Zealand Air Force Ensign | 4-1 |
| 4.1.2 Flags and flagpoles | 4-1 |
| 4.1.3 RNZAF Ensign procedures..... | 4-2 |
| Chapter 2 – The Queen's Colour | 4-5 |
| 4.2.1 Occasions when the Queen's Colour may be paraded..... | 4-5 |
| 4.2.2 Composition of Queen's Colour parties | 4-5 |
| 4.2.3 Compliments to be paid | 4-7 |
| 4.2.4 Queen's Colour position on parades | 4-7 |
| 4.2.5 Roles of QCP/Squadron Standard parties | 4-8 |
| Chapter 3 – Colour and Standard Drill | 4-9 |
| 4.3.1 General instructions | 4-9 |
| 4.3.2 Uncasing the Queen's Colour/Squadron Standard..... | 4-9 |
| Table 4-3-1 Procedure for Uncasing the Queen's Colour/ Squadron Standard | 4-9 |
| 4.3.3 Casing the Queen's Colour/Squadron Standard..... | 4-10 |
| Table 4-3-2 Procedure for Casing the Queen's Colour/ Squadron Standard | 4-10 |
| 4.3.4 Positions with the Queen's Colour/Squadron Standard | 4-12 |
| 4.3.5 Marching Queen's Colour/Squadron Standards on and off parade | 4-17 |
| Table 4-3-3 Marching Queen's Colour/Squadron Standards onto the Parade | 4-18 |
| Table 4-3-4 Marching Queen's Colour/Squadron Standards Off the Parade | 4-19 |
| 4.3.6 Procedure when on parade with a squadron | 4-19 |
| 4.3.7 Procedure with a guard of honour | 4-20 |

| | |
|--|-------------|
| Chapter 4 – Presentation, Handing Over and Laying-up of Queen's Colour or Squadron Standard | 4-23 |
| Section 1 – The consecration and presentation of Queen's Colour or Squadron Standard | 4-23 |
| 4.4.1 Parade formation | 4-23 |
| 4.4.2 Parade procedure | 4-23 |
| Table 4-4-1 Presentation of the Queen's Colour/Squadron Standard | 4-24 |
| Section 2 – Ceremony for handing over Queen's Colour/Squadron Standard | 4-28 |
| 4.4.3 Parade formation | 4-28 |
| 4.4.4 Preliminary procedure at assembly area | 4-28 |
| Table 4-4-2 Fall-in Procedure for Handover of Queens Colour/Squadron Standard | 4-29 |
| Table 4-4-3 Procedure for the Handover of Queens Colour/Squadron Standard | 4-30 |
| Section 3 – Laying-up of the Queen's Colour/Squadron Standard | 4-33 |
| 4.4.5 Order of service | 4-33 |
| Section 4 – Alternative procedure for the ceremony of parading the Queens Colour/Squadron Standard | 4-35 |
| 4.4.6 General | 4-35 |
| 4.4.7 Parade form up | 4-35 |
| 4.4.8 Parade procedure | 4-35 |
| Table 4-4-4 Procedure for Indoor Handover of Queen's Colour/Squadron Standard | 4-36 |
| Chapter 5 – King's Birthday Parade with Queen's Colour Handover | 4-39 |
| Section 1 – Outdoor parade procedures | 4-39 |
| 4.5.1 Introduction | 4-39 |
| 4.5.2 Parade form up procedure | 4-40 |
| Table 4-5-1 Form Up for King's Birthday Parade with Queen's Colour Handover | 4-40 |
| 4.5.3 Reception of the reviewing officer | 4-42 |
| Table 4-5-2 Procedure for the Reception of the Reviewing Officer | 4-42 |
| 4.5.4 Inspection of the escort squadron | 4-42 |

UNCLASSIFIED

NZAP 2.4 Manual of Ceremonial and Drill

Version 6.00

Part 4 - Queen's Colour and Squadron Standard Ceremonial Drill

13 June 2023

Contents

| | | |
|---|---|------|
| 4.5.5 | Handing over the Queen's Colour | 4-43 |
| | Table 4-5-3 Procedure for Handover of the Queen's Colour/ Squadron Standard | 4-43 |
| 4.5.6 | Parading the Queen's Colour | 4-46 |
| | Table 4-5-4 Procedure for Parading the Queen's Colour | 4-46 |
| 4.5.7 | Advance in review order..... | 4-47 |
| | Table 4-5-5 Procedure for the Advance in Review Order | 4-47 |
| 4.5.8 | Honouring the Sovereign's birthday | 4-47 |
| | Table 4-5-6 Procedure for Honouring the Sovereign's Birthday | 4-47 |
| 4.5.9 | March past of the escort squadron | 4-48 |
| | Table 4-5-7 March Past of the Escort Squadron..... | 4-48 |
| 4.5.10 | Beating retreat (optional)..... | 4-49 |
| 4.5.11 | Departure of the reviewing officer..... | 4-49 |
| | Table 4-5-8 Procedure for the Departure of the Reviewing Officer | 4-49 |
| 4.5.12 | March off and dismissal..... | 4-50 |
| 4.5.13 | Lodging the Queen's Colour..... | 4-50 |
| | Table 4-5-9 Procedure for Lodging the Queen's Colour..... | 4-50 |
| 4.5.14 | Sentry change | 4-51 |
| | Table 4-5-10 Procedure for Changing the Queen's Colour Sentries | 4-52 |
| 4.5.15 | Dislodging the QC..... | 4-52 |
| | Table 4-5-11 Procedure for Dislodging the Queen's Colour | 4-53 |
| Section 2 – Alternative Procedures for the Queen's Colour handover parade | | 4-53 |
| 4.5.16 | Introduction..... | 4-53 |
| 4.5.17 | Assembly and march on | 4-54 |
| | Table 4-5-12 Assembly and March on for the Alternative Queen's Colour Parade | 4-54 |
| 4.5.18 | Wet weather form up | 4-54 |
| 4.5.19 | Alternative parade procedure | 4-54 |
| | Table 4-5-13 Alternative procedure for handing over the Queen's Colour..... | 4-55 |

UNCLASSIFIED

NZAP 2.4 Manual of Ceremonial and Drill

Version 6.00

Part 4 - Queen's Colour and Squadron Standard Ceremonial Drill

13 June 2023

Contents

| | |
|--|-------------|
| Chapter 6 – Squadron Standards | 4-62 |
| 4.6.1 General | 4-62 |
| 4.6.2 Occasions on which Squadron Standards may be paraded | 4-62 |
| 4.6.3 Position of Squadron Standards on parade | 4-62 |
| Figure 4-6-1 Composition of Combined Queen's Colour/ Squadron Standard Party | 4-63 |
| 4.6.4 Compliments to be paid | 4-63 |
| 4.6.5 The salute by lowering the Squadron Standard | 4-64 |
| 4.6.6 The Royal Standard and other personal standards | 4-64 |
| 4.6.7 Roles of SqnSPs | 4-64 |
| Chapter 7 – Presentation of a Squadron Standard | 4-65 |
| 4.7.1 Introduction | 4-65 |
| 4.7.2 Assembly and march on of support squadrons and padres/chaplains | 4-65 |
| 4.7.3 Assembly of the Squadron Standard escort squadron and Squadron Standard party | 4-65 |
| Table 4-7-1 Assmebly and Fall in of Escort Squadron and Squadron Standard Party | 4-66 |
| 4.7.4 Reception of the reviewing officer | 4-68 |
| Table 4-7-2 Procedure for Receiving the Reviewing Officer | 4-68 |
| 4.7.5 Dedication of the Squadron Standard | 4-68 |
| Table 4-7-3 Procedure for the Dedication of a Squadron Standard | 4-68 |
| 4.7.6 Presentation of the Squadron Standard | 4-71 |
| Table 4-7-4 Procedure for the Presentation of a Squadron Standard | 4-71 |
| 4.7.7 Parading the Squadron Standard | 4-72 |
| Table 4-7-5 Procedure for parading a Squadron Standard | 4-72 |
| 4.7.8 Advance in review order | 4-74 |
| Table 4-7-6 Procedure for Advance in Review Order | 4-74 |
| 4.7.9 Three Cheers for the Sovereign | 4-75 |
| Table 4-7-7 Procedure for Honouring the Sovereign | 4-75 |
| 4.7.10 Departure of the reviewing officer | 4-75 |
| 4.7.11 March off | 4-75 |

UNCLASSIFIED

NZAP 2.4 Manual of Ceremonial and Drill

Version 6.00

Part 4 - Queen's Colour and Squadron Standard Ceremonial Drill

13 June 2023

Contents

| | | |
|---|--|-------------|
| Table 4-7-8 | Procedure for March off and Dispersal of a Squadron Standard Presentation Parade | 4-75 |
| 4.7.12 | Lodging a Squadron Standard | 4-76 |
| 4.7.13 | Lodging of the Squadron Standard in the squadron hangar by the escort flight | 4-76 |
| Table 4-7-9 | Procedure for Quitting the Parade Ground before Lodging a Squadron Standard | 4-76 |
| Table 4-7-10 | Procedure for Lodging a Squadron Standard in a Squadron Hangar | 4-77 |
| 4.7.14 | Sentry change | 4-78 |
| 4.7.15 | Dislodging the Squadron Standard | 4-78 |
| Figure 4-7-1 | Parade Positions and Markers A. | 4-79 |
| Figure 4-7-2 | Parade Positions and Markers B. | 4-80 |
| Figure 4-7-3 | Parade Positions and Markers C. | 4-81 |
| Chapter 8 – King's Birthday Parade without Queen's Colour | | 4-82 |
| 4.8.1 | King's birthday parade | 4-82 |
| Table 4-8-1 | Procedure for the Sovereign's Birthday Parade without the Queen's Colour | 4-82 |
| 4.8.2 | Wet weather format | 4-85 |
| Chapter 9 – Parading the Queen's Colour on His Majesty's Official Birthday with Support Squadrons. | | 4-87 |
| Section 1 – Support squadrons armed | | 4-87 |
| 4.9.1 | Sequence of parade | 4-87 |
| 4.9.2 | Parade composition | 4-88 |
| 4.9.3 | Dress. | 4-88 |
| 4.9.4 | Parade formation | 4-89 |
| 4.9.5 | Parade form up | 4-89 |
| Table 4-9-1 | Procedure for Forming Up to Parade the Queen's Colour on the Sovereign's Official Birthday | 4-89 |
| 4.9.6 | Ceremonial | 4-90 |
| Table 4-9-2 | Procedure for Parading the Queen's Colour on the Sovereign's Official Birthday | 4-90 |

Contents

| | |
|--|--------------|
| Section 2 – Support squadrons unarmed | 4-97 |
| 4.9.7 Sequence of parade | 4-97 |
| 4.9.8 Parade composition | 4-97 |
| 4.9.9 Dress..... | 4-97 |
| 4.9.10 Parade formation | 4-97 |
| 4.9.11 Parade form up | 4-97 |
| 4.9.12 Ceremonial | 4-97 |
| Chapter 10 – Freedom of Entry to a City or Town | 4-98 |
| 4.10.1 Introduction..... | 4-98 |
| 4.10.2 Historical background..... | 4-98 |
| 4.10.3 Granting of freedom..... | 4-98 |
| 4.10.4 General..... | 4-99 |
| 4.10.5 Forming up..... | 4-99 |
| 4.10.6 Parade ceremony | 4-100 |
| Table 4-10-1 Procedure for the Freedom of the City Parade | 4-100 |
| 4.10.7 Dismissal | 4-102 |
| 4.10.8 Form of resolution | 4-103 |
| Figure 4-10-1 Suggested Format of Resolution Deed Granting Freedom of a City..... | 4-104 |
| Chapter 11 – Beating Retreat | 4-105 |
| 4.11.1 Introduction..... | 4-105 |
| 4.11.2 Historical background..... | 4-105 |
| 4.11.3 Components of a beating retreat..... | 4-105 |
| 4.11.4 Organisation | 4-107 |
| 4.11.5 Occasions to perform | 4-108 |
| 4.11.6 General format | 4-108 |
| 4.11.7 Beating retreat format | 4-108 |
| Figure 4-11-1 Suggested Introduction for Public Beating Retreat Ceremony | 4-111 |

UNCLASSIFIED

NZAP 2.4 Manual of Ceremonial and Drill

Version 6.00

Part 4 - Queen's Colour and Squadron Standard Ceremonial Drill

13 June 2023

Contents

| | |
|--|--------------|
| Chapter 12 – RNZAF Commemorative Service, Wellington Cathedral of St Paul | 4-112 |
| 4.12.1 Historical significance | 4-112 |
| 4.12.2 Memorial | 4-112 |
| 4.12.3 Laid up emblems | 4-112 |
| 4.12.4 Queen's Colour and RNZAF Squadron Standards | 4-112 |
| 4.12.5 Uncasing the Queen's Colour and Squadron Standards. | 4-112 |
| 4.12.6 Handing over of weapons. | 4-113 |
| Table 4-12-1 Weapons Orderlies Receiving Weapons Before Entry into the Cathedral | 4-113 |
| 4.12.7 QCP/SqnSP assembly | 4-114 |
| 4.12.8 VIP procession | 4-115 |
| 4.12.9 Kaikaranga | 4-115 |
| 4.12.10 Procession of the QC and SqnSs | 4-115 |
| Table 4-12-2 Procession of Queen's Colour/Squadron Standard(s) inside the Cathedral | 4-115 |
| 4.12.11 Retrieval of the QC and SqnSs | 4-117 |
| Table 4-12-3 Recession of the Queen's Clour/Squadron Standards | 4-117 |
| 4.12.12 Casing the QC | 4-118 |
| 4.12.13 Return of weapons | 4-118 |
| Table 4-12-4 Procedure for the Return of Weapons | 4-119 |

Chapter 1 – The Royal New Zealand Air Force Ensign

4.1.1 Royal New Zealand Air Force Ensign

- a. Instructions for flying the Royal New Zealand Air Force (RNZAF) Ensign are contained in [AFGO](#) *Air Force General Orders* Part 11, Chapter 7, Section 9.
- b. The RNZAF Ensign is to flown daily at Air Staff, the headquarters of RNZAF commands and on RNZAF bases. It is also to be flown at all camps of Regular or non-Regular RNZAF units located other than on an RNZAF base ie deployed.
- c. The RNZAF Ensign is to be raised in the morning and lowered in the evening on the same day as directed by Base Routine Orders.
- d. Until the intervention of the Second World War, an armed guard turned out for both the raising and lowering of the RNZAF Ensign. A trumpeter sounded 'Attention', the RNZAF Ensign was raised, the general salute was then sounded by the trumpeter and the guard presented arms. When the 'Attention' was sounded, all officers and other ranks (ORs) within hearing of the trumpet call were required to halt, stand to attention and face the flagpole.
- e. The same procedure was prescribed for the lowering, except that the 'Retreat' was sounded as the RNZAF Ensign was lowered, and guards and escorts within hearing of the trumpet presented arms.
- f. Officers always saluted as the RNZAF Ensign was raised or lowered.
- g. On suitable ceremonial occasions, and at the discretion of the base commander (BCDR), the full ceremony contained in paragraph [4.1.3](#) can be observed.

4.1.2 Flags and flagpoles

- a. The segments of a flag are as follows—
 - (1) The part of the flag nearest the halyard (rope) is called the hoist.
 - (2) The part furthest from the halyard is called the fly.
 - (3) The upper half of the hoist is called the first quarter of the flag.
 - (4) The upper half of the fly is the second quarter.
 - (5) The lower halves of hoist and fly are the third and fourth quarters.
 - (6) The first quarter or canton is the place of honour on a flag.
- b. **Breaking a flag.** A flag (eg the Sovereign's personal flag for New Zealand) is said to be broken when it is allowed to break free at the mast head after having been furled and raised to the mast head in that condition.
- c. The RNZAF Ensign is not to be broken but is to be raised to the peak of the flagpole during the playing of a 'general salute'; likewise it is to be lowered to a 'general salute'.

UNCLASSIFIED

NZAP 2.4 Manual of Ceremonial and Drill
 Part 4 - Queen's Colour and Squadron Standard Ceremonial Drill
 Chapter 1 – The Royal New Zealand Air Force Ensign

Version 6.00
 13 June 2023

- d. **Half-masting.** The RNZAF Ensign is flown at the half-mast position as a sign of national mourning. It is brought to the half-mast position by raising it to the peak of the flagpole. It is essential that it is lowered to a position that is recognisable as half-mast to avoid any impression that the RNZAF Ensign may have accidentally fallen away from the peak of the flagpole. Half-mast is normally that position occupied by the RNZAF Ensign when lowered by its depth, plus a little extra. To lower the RNZAF Ensign from the half-mast position it must first be raised to the peak of the flagpole.

4.1.3 RNZAF Ensign procedures

- a. Raising the RNZAF Ensign

The orderly officer (OO)/duty officer (DO) and duty non-commissioned officer (DNCO)/Assistant Duty Officer (ADO) carry out the following actions—

- (1) The OO/DO marches out, halts in line with the flagpole and faces it.
- (2) The DNCO/ADO positions themselves at the base of the flagpole and connects the ensign to the halyards (shortest cleat to the top of the RNZAF ensign), once securely connected the folded ensign is tucked under the left arm and not touching the ground. The DNCO/ADO turns about to face the OO/ADO or the parade ground. The right hand is to be cut away signalling to the OO/DO they are ready.
- (3) The OO/DO, in a voice loud enough for any person within the proximity of the flagpole to hear, gives the command—

STAND FAST

- (4) The DNCO/ADO raises the RNZAF Ensign to the peak of the flagpole with a smooth, continuous movement, drawing down on the hauling rope with thumb and forefinger of alternate hands.
 - (5) The OO/DO (officers only) is to salute.
 - (6) When the RNZAF Ensign has been raised, the OO/DO gives the command—
- CARRY ON**
- (7) On the command 'CARRY ON' the salute is completed.
 - (8) The DNCO/ADO secures the halyard.
 - (9) The OO/DO and the DNCO/ADO march off.

- b. Lowering the RNZAF Ensign

- (1) The process for lowering the RNZAF Ensign is the reverse of the procedure for raising the RNZAF Ensign.
- (2) When the RNZAF Ensign has been lowered and the duty party have dismissed the RNZAF Ensign, it is to be folded correctly in accordance with [NZAP 3327 Colours, Standards, Flags and Badges in the Royal New Zealand Air Force](#), and stored in accordance with the duties directive.

Note: If the RNZAF Ensign is damp it should be dried before folding. Further details relating to flags are contained in [NZAP 3327](#).

- c. Trumpet calls for raising and lowering the RNZAF Ensign
- (1) Trumpeters are to fall in at a position, where possible, three paces to the right and two paces to the front of the flagpole, facing the parade. About half a minute before the RNZAF Ensign is to be raised, the parade commander (PCDR) gives the commands—
 - TRUMPETER**
 - SOUND THE STILL**
 - AND WHEN THE STILL HAS BEEN SOUNDED**
 - PARADE**
 - PARADE – SHUN**
 - TRUMPETER**
 - SOUND THE ALERT**
 - GENERAL SALUTE**
 - PRESENT – ARMS**
 - or if no armed party is present or acting as OO/DO—
 - SOUND THE GENERAL SALUTE**
 - (2) When the RNZAF Ensign has been raised, the PCDR gives the commands—
 - SHOULDER – ARMS**
 - TRUMPETER**
 - SOUND THE CARRY ON**
 - (3) The same procedures are followed when lowering the RNZAF Ensign, except that it is lowered to the 'Retreat'.
- d. **Handling and folding the RNZAF Ensign.** When raising or lowering the RNZAF Ensign, the non-commissioned officer (NCO) detailed is to ensure that it is handled with becoming dignity and at no time is it to touch the ground.
- e. **Raising the RNZAF Ensign.** The RNZAF Ensign is to be attached to the halyards, the folds held over the free arm and slowly raised to the peak, to coincide with the duration of the salute. On completion of the salute, the NCO resumes the position of attention, maintaining a hold on the halyards, until the sounding of the 'Carry on', when they are to secure the halyards neatly to the cleat.
- f. **Lowering the RNZAF Ensign.** The halyards are to be freed from the cleat and the NCO assumes the position of attention, holding the halyards in one hand. The lowering of the RNZAF Ensign is to coincide with the duration of the 'Retreat', one hand being used to catch the RNZAF Ensign at the fly. The folds are to be collected in the arms to prevent contact with the ground. On the sounding of the 'Carry on', the NCO is to detach the RNZAF Ensign from the halyards, which are to be secured to the cleat. They are then to fold the RNZAF Ensign.

- g. **Folding the RNZAF Ensign.** The RNZAF Ensign is first to be folded along its length (for a 3 m by 2 m ensign two folds are to be made), to make a width of approximately 0.5 m. It is then to be folded to half its length. This folding is to be repeated twice more so that the ensign is finally folded in eight folds lengthwise with a portion of the Union Jack showing uppermost. After folding, the RNZAF Ensign it is to be carried on the extended forearm to its place of custody.

Note: For a 3 m by 2 m RNZAF Ensign, an orderly is required to assist in catching the fly and folding. The RNZAF Ensign is never to be broken at the peak.

Chapter 2 – The Queen's Colour

4.2.1 Occasions when the Queen's Colour may be paraded

The Queen's Colour (QC) may be paraded as follows—

- (1) By a guard of honour mounted for His Majesty the King, or other members of the Royal Family.
- (2) By a guard of honour mounted for those persons shown in [AFGO Air Force General Orders](#).
- (3) At a parade in celebration of the birthday of the His Majesty the King.
- (4) At a parade on a date decided by the Chief of Air Force (CAF) near the anniversary of the formation of the Royal New Zealand Air Force (RNZAF), ie 1 April each year.
- (5) On such other important ceremonial occasions as may be directed by Air Staff. The QC is not to be used subordinate to any other event. For example, in paragraph [4.2.1\(4\)](#) at an evening function to celebrate 1 April, the principal ceremonial event, if one is ordered, is the Beating Retreat (refer to Part 4, [Chapter 11](#)). This may occur at the officers mess or other venue. The QC should not be used as a back drop or display.

4.2.2 Composition of Queen's Colour parties

- a. The retiring Queen's Colour party (QCP) comprises—
 - (1) Colour bearer (QCB) - one flight lieutenant (FLTLT).
 - (2) Colour warrant officer (W/O) - one W/O.
 - (3) Colour escort - two flight sergeants (F/Ss).
 - (4) Colour orderly - one sergeant (SGT).
- b. The receiving QCP comprises—
 - (1) Colour bearer - one FLTLT.
 - (2) Colour W/O - one W/O.
 - (3) Colour escort - two F/Ss.
 - (4) Colour orderly - one SGT.
- c. The QC escort flight is comprised of—
 - (1) One FLTLT as FLTCDR.
 - (2) One flying officer (FGOFF)/pilot officer (PLTOFF) as supernumerary officer.
 - (3) Four senior non-commissioned officers (SNCOs) as guides/markers.
 - (4) 48 other ranks (ORs) in the ranks.

UNCLASSIFIED

NZAP 2.4 Manual of Ceremonial and Drill
Part 4 - Queen's Colour and Squadron Standard Ceremonial Drill
Chapter 2 – The Queen's Colour

Version 6.00
13 June 2023

d. Dress

- (1) No.1A Service Dress as ordered in accordance with NZAP 207 Royal New Zealand Air Force Dress Instructions.
- (2) The Colour belt is to be worn over the left shoulder with the socket in the centre of the body.
- (3) The sword belt is to be passed through the loops inside the Colour belt.
- (4) Medals, if worn, are to be worn on the uniform in the normal manner.
- (5) The two F/S QC escorts are to wear Colour sashes. These are to be worn over the right shoulder.

e. Arms

- (1) Officers and W/Os - swords.
- (2) ORs - rifles with bayonets fitted and with ceremonial white slings.
- (3) All members of QCP are to wear white gloves.

f. Draping

- (1) When the QC is carried at a Service funeral or memorial service of a monarch, it is to be draped with a black bow.
- (2) The QC is not to be draped when paraded on any other occasion.
- (3) The QC is to be draped with a piece of crepe 2.4 m long by 32 cm wide, tied in a bow around the foot of the gilt crown in such a manner that the span of the bow is 30 cm. The ends, which should be pointed in a single point, then hang about half way down the QC.

g. Transport

- (1) The QC is at all times to be moved by air or road in a suitable vehicle, to ensure that it is handled with becoming dignity.
- (2) It is to be cased when in transit.
- (3) It is always to be accompanied by the belt, socket and the QC record book.
- (4) It is to be in the charge of an armed party, which is to consist of an officer wearing a sword and two F/Ss armed with rifles with bayonets fitted, except when the QC escort is in a vehicle.

UNCLASSIFIED

NZAP 2.4 Manual of Ceremonial and Drill
 Part 4 - Queen's Colour and Squadron Standard Ceremonial Drill
 Chapter 2 – The Queen's Colour

Version 6.00
 13 June 2023

4.2.3 Compliments to be paid

a. QCP and escort flight

When the QC is uncased, the QCP and escort flight are not to pay compliments except to persons entitled to the compliment of having the QC lowered or 'let fly'. When the QC is cased, the QCP and escort flight are to pay such compliments as would be appropriate if no QC were present.

b. Further compliments to be paid—

- (1) Individuals are always to salute an uncased QC when passing or being passed by it.
- (2) An individual carrying a rifle is to give a butt salute when passing an uncased QC. They to halt and present arms if the QC passes them.
- (3) Where an uncased QC passes an unarmed party on the march, the unarmed party is to halt, turn into line and salute, and the QC, if at the shoulder, is to be brought to the carry. If the party is armed it is to halt, turn into line and present arms.
- (4) When a party on the march passes an armed party at the halt with an uncased QC at the order, the party at the halt is to be brought to attention, the QC to the carry. The marching party is to give eyes right/left.
- (5) Parties with a cased QC are always to pay compliments to an uncased QC.
- (6) When two parties pass, each carrying a cased or uncased QC, no compliments are to be exchanged.
- (7) The salute by lowering a QC may be made only when a Royal Salute is given and when receiving or marching (in slow time) past his Majesty the King, other members of the Royal Family and those persons shown in AFGO. Other reviewing officers may be saluted by letting fly the QC without lowering it, including—
 - (a) Marshal of the Royal Air Force (RAF);
 - (b) Admiral of the Fleet (Royal Navy); and
 - (c) Field Marshal (British Army).

4.2.4 Queen's Colour position on parades

- a. **Squadron in close column of flights.** Six paces centrally in front of No.1 Flight.
- b. **Squadron in line of flights.** Centrally in front of the squadron.
- c. **Squadron in column of route.** Six paces in front of the guide and marker of No 2 Flight and two paces in rear of the last section of supernumeraries of No.1 Flight.
- d. **When the QC carried in review order.** These distances are to be adjusted as the squadron marches off.

UNCLASSIFIED

NZAP 2.4 Manual of Ceremonial and Drill

Version 6.00

Part 4 - Queen's Colour and Squadron Standard Ceremonial Drill

13 June 2023

Chapter 2 – The Queen's Colour

- e. **When the QC with a wing on parade.** The QC is to be paraded with No.1 Squadron.
- f. **When the QC carried at a Service funeral.** The QC, draped, is to be paraded with its escort flight, which is to form part of the escort party. The QC escorts are to maintain their normal posture.
- g. **When the QC is paraded for route lining.** The QC is to be on the off side of the road (looking in the direction in which the procession is moving), and is to be moved to the other side of the road if the procession is returning by the same route. The QC is normally to be paraded in the centre of the length of route lined by the RNZAF.

4.2.5 Roles of QCP/Squadron Standard parties

- a. RNZAF QCP/Squadron Standard parties (SqnSPs) are configured as a complete unit of five personnel. Each component of the party is integral to the unit as a whole.
- b. There are no occasions when the QC is to be separated from its various components.
- c. The W/Os role is to support the QCB at any time the QC is to be attended to and/or dressed as appropriate.
- d. The role of the RNZAF QCP/SqnSPs is to protect the QC/Squadron Standard (SqnS) at all times. To achieve this there will be significant times when members of the QCP/SqnSPs will not salute as to do so would render the QC/SqnS vulnerable. Royal salutes are the only exceptions to this rule.

Note: Under no circumstances is the QC is to be used for rehearsals. A practice colour is to be maintained for this purpose.

Chapter 3 – Colour and Standard Drill

4.3.1 General instructions

- a. The movements in Queen's Colour (QC)/ Squadron Standard (Sqns) drill are to be performed in the same time as rifle exercises (refer to Part 1, [Chapter 5](#)).
- b. When there are only two motions with the QC/Sqns instead of three with the rifle; the QC/Sqns is to be moved on the first and third motions of the rifle.
- c. The right hand only is to be used, except when changing arms or as stated in the drill.

4.3.2 Uncasing the Queen's Colour/Squadron Standard

The procedure for uncasing the QC/Sqns is shown in Table [4-3-1](#).

Table 4-3-1 Procedure for Uncasing the Queen's Colour/Squadron Standard

| Serial | Commander | Command | Action |
|--------|---------------|----------------------------------|--|
| 1 | Bearer | COLOUR PARTIES SHUN | – QCP/SqnSPs come to the attention position. |
| 2 | Drummer | | – Starts first drum roll. |
| | Bearer | ESCORTS ON - GUARD | |
| 3 | Drummer | | – Starts second drum roll. |
| | Bearer | UNCASE THE QUEEN'S COLOUR | |
| 4 | W/O (quietly) | RIGHT TURN | – W/Os and orderlies turn right. |
| 5 | Drummer | | – Strikes 2 x 3 drum beats. |
| | W/O (quietly) | QUICK MARCH | – W/O and orderly step off and march into position in front of QC/Sqns. |
| 6 | W/O (quietly) | HALT | – W/O and orderly halt approximately 4 paces centrally in front of the QCB/SqnSB so that the W/O can support the QC/Sqns. |
| 7 | Drummer | | – Starts third drum roll |
| | W/O (quietly) | LEFT TURN | – W/O and orderly turn left. |
| 8 | Bearer | | – The bearer brings the cased QC to the horizontal position with the pike under the right arm. – The W/O supports the cased QC. |
| 9 | Bearer | | – Bearer(s) to untie the tapes with their left hand |

| Table 4-3-1 Procedure for Uncasing the Queen's Colour/Squadron Standard (cont.) | | | |
|--|------------------|------------------------------------|--|
| Serial | Commander | Command | Action |
| 10 | W/O | | <ul style="list-style-type: none"> - W/O removes the case and hands it to the orderly. - W/O frees the tassels so that they hang from the head of the pike. - The QCB/SqnSB supports the folded QC/SqnS as the case is removed. - The QC is released and permitted to hang straight down from the pike to ensure that it will fly correctly. |
| 11 | Bearer | | <ul style="list-style-type: none"> - The bearer brings the QC/SqnS to order and dresses it. |
| 12 | W/O & orderly | | <ul style="list-style-type: none"> - W/O draws their sword, salutes and returns to the carry position. - At the same time, the orderly salutes. |
| 13 | Drummer | | <ul style="list-style-type: none"> - Starts fourth drum roll. |
| | W/O (quietly) | LEFT TURN | <ul style="list-style-type: none"> - W/O and orderly turn left. |
| 14 | Drummer | | <ul style="list-style-type: none"> - Strikes 2 x 3 beats |
| | W/O (quietly) | QUICK MARCH | <ul style="list-style-type: none"> - W/O and orderly step off together and quick march back towards their previous position. behind the bearer. |
| 15 | W/O (quietly) | HALT | <ul style="list-style-type: none"> - W/O and orderly halt behind the bearer. |
| 16 | W/O (quietly) | RIGHT TURN | <ul style="list-style-type: none"> - W/O and orderly turn right. |
| 17 | Drummer | | <ul style="list-style-type: none"> - Starts fifth drum roll. |
| | Bearer | ESCORTS SHOULDER - ARMS | <ul style="list-style-type: none"> - The escorts shoulder arms. |
| 18 | Drummer | | <ul style="list-style-type: none"> - Starts sixth drum roll. |
| | Bearer | ESCORTS INWARDS TURN | <ul style="list-style-type: none"> - Escorts turn inwards. |

4.3.3 Casing the Queen's Colour/Squadron Standard

The procedure for casing the Queen's Colour/a Squadron Standard is shown in Table [4-3-2](#).

Table 4-3-2 Procedure for Casing the Queen's Colour/Squadron Standard

| Serial | Commander | Command | Action |
|--|------------------|---|--|
| All parties are to be at attention. (Orderlies are to have formed up next to their respective W/Os) | | | |
| 1 | Bearer | CASE THE QUEEN'S COLOUR OF THE ROYAL NEW ZEALAND AIR FORCE/SQUADRON STANDARD OF ___ SQUADRON | |
| 2 | Bearer | COLOUR PARTY SHUN | <ul style="list-style-type: none"> - The QCP/SqnSPs come to the attention position. |

| Table 4-3-2 Procedure for Casing the Queen's Colour/Squadron Standard (cont.) | | | |
|--|------------------|-----------------------------------|---|
| Serial | Commander | Command | Action |
| 3 | Drummer | | – Starts first drum roll |
| | Bearer | ESCORTS INWARDS - TURN | – The escorts turn inwards. |
| 4 | Drummer | | – Starts second drum roll. |
| | Bearer | ESCORTS PRESENT - ARMS | – The escorts take up the present arms position. |
| 5 | Drummer | | – Starts third drum roll. |
| | W/O (quietly) | RIGHT TURN | – The W/O's and orderlies: right turn. |
| 6 | Drummer | | – The drummer strikes 2 x 3 drum beats. |
| | W/O (quietly) | QUICK MARCH | |
| 7 | W/O (quietly) | HALT | – The W/O and orderly halt approximately 4 paces in front of QCB/SqnSB. |
| 8 | Drummer | | – Starts fourth drum roll. |
| | W/O (quietly) | LEFT TURN | – The W/O and orderly turn left. |
| 9 | Drummer | | – Starts fifth drum roll. |
| | W/O (quietly) | SALUTE | – The W/O and orderly salute. – The W/O return their sword to the carry position. |
| 10 | Drummer | | – Starts sixth drum roll. – The bearer lowers the colour to the horizontal position (to the count of five). – The bearer holds the pike under their right arm. – The W/O steps forward and assists the bearer to fold the QC/SqnS as follows— – The QC/SqnS is grasped at the corners of the fly. – The edge of the fly is placed just over the pike. – This operation is repeated twice more so that the QC/SqnS is finally folded in eight folds, resting on top of the pike. – The tassels are spiralled around the QC/SqnS three times with care being taken to not crease the QC/SqnS in any way. Refit the drape. – The W/O replaces the chamois cover over the crown at the top of the pike. – The W/O slides the case over the QC/SqnS ensuring that it is not creased. – The W/O ties off the cover. |

UNCLASSIFIED

NZAP 2.4 Manual of Ceremonial and Drill
 Part 4 - Queen's Colour and Squadron Standard Ceremonial Drill
 Chapter 3 – Colour and Standard Drill

Version 6.00
 13 June 2023

| Table 4-3-2 Procedure for Casing the Queen's Colour/Squadron Standard (cont.) | | | |
|--|------------------|-----------------------------------|---|
| Serial | Commander | Command | Action |
| 10 (cont.) | | | <ul style="list-style-type: none"> - The W/O assists the bearer to bring the cased colour to the order. - W/O steps back alongside the orderly. |
| 11 | Drummer | | <ul style="list-style-type: none"> - Starts seventh drum roll. |
| 12 | Drummer | | <ul style="list-style-type: none"> - 2 x 3 Beat rolls. - W/O and orderly— <ul style="list-style-type: none"> - step off together; - quick march back to their positions; and - halt in single file. - Orderly moves to a position off to the side rear of the party. - W/O remains facing in the single file direction. |
| 13 | Drummer | | <ul style="list-style-type: none"> - Starts eighth drum roll. |
| 14 | Drummer | | <ul style="list-style-type: none"> - Starts ninth drum roll. |
| | W/O (quietly) | ESCORTS SHOULDER ARMS | <ul style="list-style-type: none"> - Escorts shoulder arms. |
| 15 | Drummer | | <ul style="list-style-type: none"> - Starts tenth drum roll. |
| | W/O (quietly) | ESCORTS OUTWARDS TURN | <ul style="list-style-type: none"> - Escorts turn outwards. |
| 16 | W/O | TO YOUR DUTIES – DISMISSED | <ul style="list-style-type: none"> - QCP/SqnSP dismiss. |

4.3.4 Positions with the Queen's Colour/Squadron Standard

a. The order—

- (1) The pike and the QC/SqnS are held with the right hand at that part of the pike to which the lowest corner of the QC/SqnS reaches.
- (2) The pike is held perpendicular with the bottom of the pike resting on the ground in line with the right toe.
- (3) The elbow is held close to the body.
- (4) The QC/SqnS is not to be stretched taut but is allowed to hang naturally down the pike.

b. Dressing the QC/SqnS—

- (1) The QC/SqnS is to be dressed at the order.
- (2) With the left hand, the QCB/SqnSB is to distribute the folds of the QC/SqnS evenly on either side of the pike so that the pike is completely covered and the Royal Cypher readily seen.

Note: There is no drill movement but the dressing is to be carried out unobtrusively whenever the QC/SqnS becomes disturbed.

c. Stand at ease/stand easy—

- (1) The QC/SqnS is brought to the order on the command 'STAND AT – EASE'.
- (2) After the third movement with the pike, the bearer adopts the stand at ease position
 - (a) left foot placed 30 cm from the right foot without stamping;
 - (b) the left arm at the side; and
 - (c) the pike held vertical.

Note: When a QC is on parade, uncased, the parade is not to be stood at ease.

d. Carry from the order—

- (1) On the command—

COLOUR PARTY

COLOUR PARTY – SHUN

- (2) The QCB/SqnSB—
 - brings the left foot in beside the right;
 - raises the QC/SqnS to a perpendicular position in front of the body, the left hand cupping the socket and the base of the pike guided into the socket with the right forearm lowered against the pike for control;
 - brings the left hand smartly to the side; and
 - at the same time raises the right forearm to a horizontal position with the right thumb in front of the mouth, back of hand to the front.

e. The shoulder from the carry—

The QCB/SqnSB—

- raises the QC/SqnS just clear of the socket of the Colour belt, the base of the pike being controlled with the left hand and the right forearm lowered against the pike;
- lowers the QC/SqnS sharply to the right shoulder;
- holds the pike at an angle of 45 degrees to the ground;
- holds the right elbow close to the side and the right forearm parallel with the ground;
- the QC/SqnS hangs over and covers the right shoulder and arm;
- the pike should not show between the hand and the shoulder, but should be covered by the end of the QC/SqnS; and
- lowers the left hand smartly to the side.

UNCLASSIFIED

NZAP 2.4 Manual of Ceremonial and Drill
Part 4 - Queen's Colour and Squadron Standard Ceremonial Drill
Chapter 3 – Colour and Standard Drill

Version 6.00
13 June 2023

- f. Changing the QC/SqnS from right to left shoulder—
- The QCB/SqnSB—
- grasps the QC/SqnS and pike with the left hand close above the right hand;
 - carries the pike smartly across the body and places it on the left shoulder in the same position as detailed in the second movement of the shoulder from the carry; and
 - lowers the right arm smartly to the side.
- g. Carry from the shoulder—
- The QCB/SqnSB—
- raises the pike sharply off the right shoulder with the right hand to the position of the carry;
 - guides the base into the socket of the Colour belt with the left hand, right forearm lowered to the pike; and
 - lowers the left hand smartly to the side and the right forearm to horizontal.
- h. Order from the carry—
- On the command—
- STAND AT – EASE**
- The QCB/SqnSB—
 - raises the pike just clear of the socket of the Colour belt, right forearm lowered to the pike for control and the left hand cupped around the top of the socket;
 - lowers the pike to the position of the order;
 - at the same time steadying it with the left hand, which is horizontal with fingers extended and together;
 - lowers the left arm smartly to the side; and
 - places the left foot 30 cm from the right.
- i. Let fly the QC/SqnS—
- The QC/SqnS is released with the right hand, which is slid down the pike to a position just below the QC/SqnS and returned to its previous position.
- j. Catch the QC/SqnS—
- The QC/SqnS is grasped with the right hand and the position of the carry resumed.
 - The left hand may be used to help in catching the QC/SqnS in a high wind.
 - The right forearm is lowered to the pike for control.

k. Lower the QC/SqnS at the halt—

(1) On the precautionary—

ROYAL/PRESIDENTIAL SALUTE

- the QC/SqnS is let fly.

(2) On the command—

PRESENT – ARMS

- The pike is raised clear of the socket of the Colour belt.
- At the same time the base of the pike is guided with the left hand, the right forearm being lowered against the pike for control.
- The pike is carried across the body to the hollow of the right shoulder, at the same time being steadied at the base of the pike with the left hand.
- The left hand is then lowered to the side.
- The QC/SqnS is then to be carried well to the right and lowered with a sweeping motion to a position in front of and in line with the right toe.
- The head of the pike is to be just clear of the ground and the QC/SqnS is to be spread on the ground to the right of the pike.
- If a strong wind is blowing from the right, the QC/SqnS is to be carried well to the left and lowered with a sweeping motion to the position in front of and in line with the right toe and the QC/SqnS is to be spread to the left of the pike.
- The pike is to be held under the right armpit, the back of the hand being towards the ground and the right elbow close to the body.
- Care is to be taken to look straight to the front when lowering the QC/SqnS; the eyes are not to follow the QC/SqnS. (When lowered in wet weather or muddy conditions the QC/SqnS is to be held in the hand to prevent it becoming soiled).

Note: The lowering of the QC/SqnS is to coincide with the duration of the particular National Anthem being played.

l. Lower the QC/SqnS when marching past—

(1) The QC/SqnS is let fly on the command 'EYES'.

(2) On the command 'RIGHT'—

- The QC/SqnS is lowered after the check pace.
- The pike is held horizontally in front of the body and rests underneath the armpit.
- The QC/SqnS hangs straight down.

m. Carry from the lowered QC/SqnS—

(1) The QCB/SqnSB—

- (a) Raises the QC/SqnS in one smooth movement, with the right hand to the position of the carry, the pressure of the pike being borne under the right armpit, the pike being steadied at the base with the left hand.
- (b) Catches the QC/SqnS with the left hand when the position of the carry has been attained.

Note: When at the halt, the QC/SqnS is to be held only at the carry or the order. When cased, the QC/SqnS is never to be held at the carry, only the shoulder. When on the march, the QC/SqnS is always to be carried at the shoulder, except when marching on or off the parade ground, when on the saluting base, when marching past and returning and advancing in review order; at these times it is to be at the carry.

n. QCP/SqnSP pivot wheeling—

(1) To enhance the ceremonial associated with the QC/SqnS and to ease wheeling in confined spaces, the QCP/SqnSP is to pivot wheel whenever a (90 or 180 degrees) change of direction is called for. However—

- (a) When the QCP/SqnSP is part of a formation on the march, a conventional wheel (dressing by the flank as in threes) is to be used to maintain distance between flights.
- (b) Normal wheels may also be executed during less formal arrival procedures to a parade area.

(2) During all pivot wheels, dressing is to be by the centre (ie dressing on the QCB/SqnSB).

(3) The pivot wheel may be carried out on the command TO THE HALT, prefixed as required, from—

- (a) the halt to the halt;
- (b) the halt to the march;
- (c) the march to the halt; or
- (d) the march to the march.

o. Right or left fixed pivot wheels—

(1) From the halt, on the command 'LEFT (RIGHT) FIXED PIVOT – WHEEL'—

- The QCB/SqnSB and the QCP/SqnSP take eight paces to complete the wheel.
- The QCP/SqnSP pivots around (and dresses on) the QCB/SqnSB.
- One escort steps forward and the other steps back.
- The QCB/SqnSB ensures they pivot on the spot.

- The W/O takes a block pace turn on the march in the opposite direction to the wheel, then wheels around behind the QCB/SqnSB, maintaining distance and adjusting direction relative to the QCB/SqnSB toward the end of the movement.
- If the movement is to the halt, all members of the QCP/SqnSP halt together on the eighth pace; otherwise they step off together with the left foot immediately after the eight paces, starting arm swing as they do so.
- Knees are raised and the arms kept at the side throughout the movement.
- Care must be taken to point the toes of the raised foot downward and keep the lower part of the raised leg as near perpendicular to the ground as possible.
- Due to the extra distance to be covered, the W/O should not exaggerate their movement, otherwise the length of pace will be restricted.

(2) From the march—

- (a) All commands on the move are given on consecutive beats of the left foot.
- (b) The QCB/SqnSB gives the command—

LEFT (RIGHT) FIXED PIVOT – WHEEL

- Each member of the QCP/SqnSP takes a check pace with the right foot, (cutting their arms to the sides as they do so).
- They then start the eight pace wheel as described in paragraph [4.3.4o.\(1\)](#).

(3) About turn—

The movement is carried out in like manner to the right fixed pivot wheel, but sixteen marching paces are taken rather than eight.

(4) From the halt—

On the command 'ABOUT FIXED PIVOT – WHEEL'—

- The QCP/SqnSP takes sixteen paces to complete the wheel. (Due to the duration of the movement, close attention must be paid to dressing.)
- The QCP/SqnSP halts on the last pace, or steps off, as in the right fixed pivot wheel, according to the command.

(5) From the move—

The QCP/SqnSP acts as in the right fixed pivot wheel, taking sixteen marching paces.

Note: The QCP/SqnSP should have completed half the turn after eight paces.

4.3.5 Marching Queen's Colour/Squadron Standards on and off parade

a. Marching on the QC/SqnS—

- (1) The QC/SqnS is to be uncased before the main parade is joined.

UNCLASSIFIED

NZAP 2.4 Manual of Ceremonial and Drill
 Part 4 - Queen's Colour and Squadron Standard Ceremonial Drill
 Chapter 3 – Colour and Standard Drill

Version 6.00
 13 June 2023

- (2) The QCP/SqnSP brings the QC/SqnS from the place where it is normally kept and forms up 25 paces from and 6 paces forward of the left flank of the parade, facing the centre of the parade ground.
 - (3) When the parade is called to attention, or stood at ease, the QCP/SqnSP conforms to the movements.
 - (4) When the parade is fully prepared (ie at attention), the parade commander (PCDR) takes up position facing the parade, 12 paces in front of and in the centre of the formation
 - (5) The procedure in Table [4-3-3](#) is followed.
- b. Marching off the QC/SqnSs—
- (1) At the end of the parade, the PCDR orders the ORs to attention and takes up a position facing the parade, 12 paces in front and in the centre of the formation.
 - (2) The procedure in Table [4-3-4](#) is followed.

Table 4-3-3 Marching Queen's Colour/Squadron Standards onto the Parade

| Serial | Commander | Command | Action |
|--------|-----------|--|---|
| 1 | PCDR | PARADE MARCH ON THE QUEEN'S COLOUR PRESENT – ARMS | – The band plays POINT OF WAR. |
| 2 | QCB/SqnSB | COLOUR PARTY BY THE CENTRE QUICK – MARCH | – The band plays the RNZAF March. – The QCP/SqnSP, under the command of the QCB/SqnSB— – marches onto the parade; and – left pivot wheels to the halt on reaching its position in the formation. |
| 3 | PCDR | PARADE SHOULDER – ARMS | – The QCP/SqnSP— – shoulders arms; and – returns to their normal position. – The QCP/SqnSP acts as part of the parade. |

Table 4-3-4 Marching Queen's Colour/Squadron Standards Off the Parade

| Serial | Commander | Command | Action |
|---|-----------|---|---|
| 1 | PCDR | PARADE MARCH OFF THE QUEEN'S COLOUR PRESENT – ARMS | – The band plays POINT OF WAR. |
| Note: The QC/SqnS do not salute when the point of war is played. | | | |
| 2 | QCB/SqnSB | COLOUR/STANDARD PARTY LEFT FIXED PIVOT – WHEEL | <ul style="list-style-type: none"> – The band plays the RNZAF March. – Under command of the QCB/SqnSB, the QCP/SqnSP— <ul style="list-style-type: none"> – completes the wheel; – marches off across the parade in the direction from which it marched on; then – continues on to the place where the QC/SqnS is to be cased. |
| 3 | | | <ul style="list-style-type: none"> – When the QCP/SqnSP has left the parade ground, the PCDR gives the command to finalise the parade and march off the squadrons. <p>Note: Marching on and marching off is carried out with the officers in review order.</p> |

4.3.6 Procedure when on parade with a squadron

- a. Forming column of threes from line—

After the squadron has turned, the QCB/SqnSB gives the command—

COLOUR/STANDARD PARTY
AT THE HALT
RIGHT FIXED PIVOT – WHEEL

- b. Forming line from column of threes—

After the squadron has turned, the QCB/SqnSB gives the command—

COLOUR/STANDARD PARTY
AT THE HALT
LEFT FIXED PIVOT – WHEEL

- c. Forming column of route from line—

After the squadron has turned the QCB/SqnSB marches the QCP/SqnSP by a series of pivot wheels, to its position at the head of No.2 Flight facing the new direction (between No.1 Flight supernumerary officers and No 2 Flight commander).

- d. Forming line from column of route—

After the squadron has turned, the QCB/SqnSB marches the QCP/SqnSP by a series of pivot wheels, to its position between No.2 Flight commander and the PCDR.

- e. Forming column (or close column) of flights from column of route—

UNCLASSIFIED

NZAP 2.4 Manual of Ceremonial and Drill

Version 6.00

Part 4 - Queen's Colour and Squadron Standard Ceremonial Drill

13 June 2023

Chapter 3 – Colour and Standard Drill

- (1) When No.1 Flight halts, the QCP/SqnSP is to lead No.2 Flight (using conventional wheels as in squadron drill refer to Part 2, [Chapter 3](#)) to the position indicated by the squadron warrant officer (SWO).
- (2) The QCP/SqnSP is not to halt with No.2 Flight, but continues marching, using a series of pivot wheels, to its new position in centre front of No.1 Flight.

f. Turning about—

After the squadron has turned about, the QCB/SqnSB marches the QCP/SqnSP to its new position, using pivot wheels round the right flank.

Note: When in line of flights, or in review order in close column, the PCDR is to be 12 paces in front of the squadron, and not six paces as in normal drill. If other squadrons are on parade, the PCDRs are to dress by No.1 Squadron. The QCP/SqnSP is never to march in file; it is always to pivot-wheel before marching in the new direction.

4.3.7 Procedure with a guard of honour

a. Marching on the QC/SqnS

- (1) The QCP/SqnSP marches on from the flank, across the front of the guard.
- (2) On reaching the centre of the parade, the QCP/SqnSP pivot wheels into the guard, then about fixed pivot wheels to halt when the QCB/SqnSB is in line with the centre rank of the two flights. (The QCP/SqnSP is then correctly aligned with the guard for a turn to the flank.)

b. Forming column of route from line (before moving to the reception area).

After the guard has turned, the QCB/SqnSB orders a left or right fixed pivot wheel to the halt.

c. Forming line from column of route (before moving to the reception area).

- (1) After the guard has turned, the QCB/SqnSB orders a left or right fixed pivot wheel to the halt.
- (2) After the halt the QCB/SqnSB gives the command—

COLOUR PARTY**TAKE – POST**

- The QCP/SqnSP takes a pace forward to cover off the front rank of the guard.
- At the same time, the QCB/SqnSB steps forward four paces to cover off the junior officer in front of No.2 Flight.

Note: The officers are to be three paces in front of the front rank, not two as in normal drill. The W/O is to cover off the rear rank.

d. Open order march

After the guard has formed two ranks, the guard commander gives the command—

OPEN ORDER – MARCH

- The QC/SqnS W/O steps back two paces with the rear rank.

e. Inwards dress

On the command—

INWARDS – DRESS

- the QCP/SqnSP adjusts its position relative to the reviewing dais so that the guard is centrally placed.

f. Royal/presidential salutes

If the guard is to pay the compliment of a Royal/presidential salute, the QC/SqnS is lowered on each such occasion. Otherwise, the QC/SqnS is let fly.

g. Inspection

(1) Immediately before the inspection of the guard by the reviewing officer, the QCB/SqnSB is to bring the QC/SqnS from the order to the carry.

(2) The QC/SqnS is to be returned to the order on completion of the inspection.

h. Close order march

The W/O steps forward two paces with the rear rank.

i. Forming column of route (before marching off)

The QCP/SqnSP acts as in paragraph [4.3.7a](#).

j. Forming line (after arrival at the original form up area) from three ranks

(1) After the guard has formed three ranks, the QCB/SqnSB gives the command—

COLOUR PARTY

TAKE – POST

- QCP takes a pace to the rear to cover off the vacant centre rank of the guard.
- At the same time, the QCB/SqnSB steps back four paces to cover off.

(2) After the guard has turned, the QCB/SqnSB orders a left/right pivot wheel to the halt. (The QCP/SqnSP retains its position in the guard, with the QCB/SqnSB and aligned with the centre rank.)

k. Marching off the QC/SqnS

(1) The QCP/SqnSP pivot wheels out of the guard in like manner to marching on.

(2) The band plays 'Point of War' before the QC/SqnS is marched on/off as in normal procedure.

UNCLASSIFIED

NZAP 2.4 Manual of Ceremonial and Drill

Version 6.00

Part 4 - Queen's Colour and Squadron Standard Ceremonial Drill

13 June 2023

Chapter 3 – Colour and Standard Drill

- (3) When space and circumstances dictate, the guard may have to march on and off the reception area in column of threes rather than column of route. In this event, the actions of the QCP/SqnSP remain the same as for column of route.

I. Showing the QC/SqnS

- (1) Showing the QC/SqnS is a custom that is observed during ceremonial parades when a period of waiting occurs, such as when providing guards of honour or when lining a route, and may be carried out at the discretion of the PCDR.
- (2) It is performed by the QCB/SqnSB who, on being commanded to 'SHOW THE COLOUR/STANDARD' —
 - shoulders the QC/SqnS;
 - marches two paces forward from the escort;
 - turns right/left; and
 - marches in quick time along the front of the parade.
- (3) This custom is not carried out when parading for a funeral.

Chapter 4 – Presentation, Handing Over and Laying-up of Queen's Colour or Squadron Standard

Section 1 – The consecration and presentation of Queen's Colour or Squadron Standard

4.4.1 Parade formation

- a. The parade, except the escort squadron, is to be formed up in wing formation, with the front rank 14 paces from the receiving base.
- b. If the inspection is to be carried out in a car, the distance between flights and/or squadrons is to be adjusted accordingly.
- c. The escort squadron, which is to be armed, is to parade centrally on the receiving base in line of flights.
- d. The band is to be positioned with its front rank in line with the rearmost flights of the wing.
- e. Drums are to be piled centrally in the area between the march past line and the saluting base. Three side drums are to be used.

4.4.2 Parade procedure

- a. Before marching onto the main parade ground, the Queens Colour party (QCP)/ Squadron Standard party (SqnsP) is to parade with the escort squadron in accordance with paragraphs 4.4.2.b.–e.
- b. The QCB/SqnsB is to be in the supernumerary rank of officers of No.2 Flight, so that in review order they will be in the centre of the flight.
- c. The QC/SqnS escort of two senior non-commissioned officers (SNCOs) is to be on the right of the supernumerary rank of non-commissioned officers (NCOs) of No.2 Flight.
- d. The warrant officer (W/O), with the QC/SqnS cased and carried at the slope, is to be on the left of the QC/SqnS escort.
- e. When the parade has been marched on (escort squadron last) and handed over to the parade commander (PCDR), the parade is to be prepared as shown in Table [4-4-1](#).

UNCLASSIFIED

NZAP 2.4 Manual of Ceremonial and Drill

Version 6.00

Part 4 - Queen's Colour and Squadron Standard Ceremonial Drill

13 June 2023

Chapter 4 – Presentation, Handing Over and Laying-up of Queen's Colour or Squadron Standard

Table 4-4-1 Presentation of the Queen's Colour/Squadron Standard

| Serial | Commander | Command | Action |
|--------|---|--|--|
| 1 | PCDR | ORDER THE OFFICERS TO TAKE POST IN REVIEW ORDER STAND THE PARADE AT EASE | <ul style="list-style-type: none"> – The W/O marches directly to the piled drums, where the cased QC/SqnS is placed against the drums, pike to the right, and returns to their previous position. – The padre/chaplains take up their positions facing the parade a few paces to the right of the pile of drums and to the rear of the saluting base. (The senior padre/chaplain is to be on the left.) – Two junior officers are positioned at Points A and B respectively (refer to Figure 4-4-1). These officers are to act on words of command of the PCDR. |
| 2 | PCDR | MARCH ON THE CASED COLOUR | – Refer to paragraph 4.3.5 . |
| 3 | Reception of the very important person (VIP) presenting the QC/SqnS | | |
| | <ul style="list-style-type: none"> – As the VIP approaches the parade ground, the parade is brought to attention. – When the VIP is in position on the dais, the Royal/general salute is given. – After the salute has been given and the parade has shouldered arms, the PCDR reports to the VIP and asks them if they would like to inspect the parade. – The VIP then inspects the parade. | | |
| 4 | Preparation for consecration and presentation. | | |
| | – At the end of the inspection, the PCDR requests permission of the VIP to proceed with the ceremony. | | |
| 5 | PCDR | ESCORT SQUADRON COMMANDER PREPARE YOUR SQUADRON FOR THE PRESENTATION OF THE QUEEN'S COLOUR | – The escort squadron commander (ESCDR) (resumes position in the centre of the squadron). |
| 6 | Bandmaster | BAND READY | |
| 7 | ESCDR | ESCORT SQUADRON FORM HOLLOW SQUARE NUMBERS 1 AND 3 FLIGHTS LEFT AND RIGHT WHEEL QUICK – MARCH | <ul style="list-style-type: none"> – The flights are to complete the wheels and halt. – The band are to advance and halt together with Nos.1 and 3 flights. |
| 8 | ESCDR | ESCORT SQUADRON FLIGHTS INWARDS – TURN RIGHT AND LEFT – DRESS EYES – FRONT | <ul style="list-style-type: none"> – The QC/SqnS is uncased. – The ESCDR takes up position in front of No.1 Flight. |
| 9 | PCDR | PARADE STAND AT – EASE | – The PCDR takes up position on the right of the VIP. |

UNCLASSIFIED

NZAP 2.4 Manual of Ceremonial and Drill

Version 6.00

Part 4 - Queen's Colour and Squadron Standard Ceremonial Drill

13 June 2023

Chapter 4 – Presentation, Handing Over and Laying-up of Queen's Colour or Squadron Standard

| Table 4-4-1 Presentation of the Queen's Colour/Squadron Standard (cont.) | | | |
|---|------------------|---------------------------------------|--|
| Serial | Commander | Command | Action |
| 10 | The ceremony | | |
| | | | <ul style="list-style-type: none"> – The VIP moves forward to a position behind the piled drums. – The Principal Chaplain moves to a position in front of the drums, facing the VIP, and the assisting padres/chaplains form a line in order of seniority on the left of the Principal Chaplain, facing the drums. – The PCDR addresses the Principal Chaplain as follows— – ‘Reverend Sir/Ma’am, on behalf of the Royal New Zealand Air Force, we ask you to bid God’s blessing on their Colour.’ – The Principal Chaplain replies— ‘We are ready to do so’, – The Principal Chaplain then proceeds with the Service of Consecration. <p>Note: Before the actual prayer of consecration the parade is to be brought to attention, and stood at ease on its completion.</p> <ul style="list-style-type: none"> – At the end of the service the padre/chaplains move to their left front and form a line on the right of the drums. |
| 11 | PCDR | PARADE PARADE – SHUN | <ul style="list-style-type: none"> – The QCP/SqnSP moves to its position without further word of command. – The QCB/SqnSB marches forward to the position where they will receive the QC/SqnS, and there return their sword. – The W/O orders the QCP/SqnSP to turn right, and marches them round the right flank of No.2 Flight to their position six paces in front of No.2 Flight. – The VIP moves round to the left in front of the drums and is handed the QC/SqnS by the PCDR. – The QCB/SqnSB— <ul style="list-style-type: none"> – moves forward; – sinks on to the right knee; – receives the QC/SqnS; – rises; and – steps backwards. – The VIP gives an address. – The PCDR thanks the VIP and requests permission to carry on. |
| 12 | PCDR | PARADE | <ul style="list-style-type: none"> – The QCB/SqnSB turns about. |

UNCLASSIFIED

NZAP 2.4 Manual of Ceremonial and Drill

Version 6.00

Part 4 - Queen's Colour and Squadron Standard Ceremonial Drill

13 June 2023

Chapter 4 – Presentation, Handing Over and Laying-up of Queen's Colour or Squadron Standard

| Table 4-4-1 Presentation of the Queen's Colour/Squadron Standard (cont.) | | | |
|---|------------------|--|--|
| Serial | Commander | Command | Action |
| 13 | PCDR | GENERAL SALUTE PRESENT – ARMS | <ul style="list-style-type: none"> – On the second movement of the 'PRESENT', simultaneously— – all officers salute; – the band starts playing the New Zealand National Anthem; and – the QCB/SqnSB— <ul style="list-style-type: none"> – steps off in slow time; – halts; – turns about; and – takes position between the QC/SqnS. |
| 14 | PCDR | PARADE SHOULDER – ARMS | <ul style="list-style-type: none"> – The VIP returns to the dais on the saluting base accompanied by the PCDR, who requests permission for the escort squadron to march past in review. – At the same time the ESCDR moves to the centre of the hollow square. |
| 15 | ESCDR | ESCORT SQUADRON FORM LINE OF FLIGHTS ON THE RECEIVING BASE NO'S.1 AND 3 FLIGHTS ABOUT – TURN | |
| 16 | Bandmaster | BAND READY | |
| 17 | ESCDR | FLIGHTS RIGHT AND LEFT WHEEL QUICK – MARCH HALT ABOUT – TURN ESCORT SQUADRON (INCLUDING COLOUR PARTY) OFFICERS TAKE POST LEFT – TURN QUICK – MARCH INWARDS – TURN | |
| 18 | PCDR | WING STAND AT – EASE ESCORT SQUADRON COMMANDER MARCH PAST YOUR SQUADRON IN REVIEW ORDER | |

UNCLASSIFIED

NZAP 2.4 Manual of Ceremonial and Drill

Version 6.00

Part 4 - Queen's Colour and Squadron Standard Ceremonial Drill

13 June 2023

Chapter 4 – Presentation, Handing Over and Laying-up of Queen's Colour or Squadron Standard

- f. Review of the escort squadron
- (1) The escort squadron marches in column of threes to Point 2, where it is to form close column of flights (refer to Figure [3-1-1](#)).
 - (2) The QCP/SqnSP moves with No.2 Flight.
 - (3) The squadron dresses by the right.
 - (4) The wing is called to attention.
 - (5) The escort squadron marches past by flights in column in slow time.
 - (6) The QCP/SqnSP follows No.1 Flight at column distance and is followed by No.2 Flight at column distance.
 - (7) On arrival at Point 3 (refer to Figure [3-1-1](#)), the escort squadron halts in close column of flights, turns about and dresses by the left.
 - (8) The wing is stood at ease.
 - (9) The wing is called to attention as the escort squadron marches past in close column of flights in quick time.
 - (10) On arrival at Point 2 (refer to Figure [3-1-1](#)), the escort squadron halts and turns about.
 - (11) The wing is stood at ease.
 - (12) The escort squadron marches to the receiving base in column of threes and halts, facing right in line of flights.
 - (13) The squadron is dressed and brought to review order.
- g. Advance in review order
- (1) The PCDR brings the wing to attention and takes up position in front of the escort squadron.
 - (2) The escort squadron, led by the PCDR, advances in review order, and the Royal Salute is given.
 - (3) At the end of the salute the parade is brought to the Shoulder.
 - (4) Three cheers for HIS MAJESTY THE KING are given.
 - (5) The PCDR reports to the VIP and requests permission to march off.
- Note:** The method of giving three cheers for HIS MAJESTY THE KING is outlined in Table [4-5-6](#).
- h. Dispersal of parade
- (1) After the escort squadron has left the parade area, squadrons/wings are to march off independently in column of route for dismissal.
 - (2) If a march past in column of route is ordered, the escort squadron leads.
 - (3) The band plays during the dispersal/march past, and then marches off.

*Section 2 – Ceremony for handing over Queen's Colour/Squadron Standard***4.4.3 Parade formation**

The strength of the squadron to carry out the ceremony is to be—

- (1) PCDR.
- (2) Receiving QCP/SqnSP—
 - (a) One flight lieutenant (FLTLT) - QCB/SqnSB.
 - (b) One W/O - QC/SqnS W/O.
 - (c) Two flight sergeants (F/Ss) - escorts to the QC/SqnS.
 - (d) One sergeant (SGT) - QC/SqnS orderly.
- (3) Three flights. The strength of each flight is to be—
 - (a) One FLTLT - FLTCDR.
 - (b) 30 other ranks (ORs) (minimum). SNCOs may be used as guides and markers.
- (4) Retiring QCP/SqnSP—
 - (a) One FLTLT - QCB/SqnSB.
 - (b) One W/O - QC/SqnS W/O.
 - (c) Two F/Ss - escorts to the QC/SqnS.
 - (d) One SGT - QC/SqnS orderly.

Note: A parade adjutant (PADJ) and squadron warrant officer (SWO) are in attendance until after the falling in of the parade. (Refer to paragraph [4.4.4b.](#))

4.4.4 Preliminary procedure at assembly area**a. General—**

- (1) The squadron is to be fallen in on the assembly area in close column of flights as space permits, otherwise it can be fallen in as a squadron in line on a roadway with the band on the right flank.
- (2) The procedure is to be the same as for a normal squadron fall in, but with the following additions—
 - (a) The receiving QCP/SqnSP escorts fall in five paces to the right of No.2 Flight, facing the front with a four pace interval between them.
 - (b) The retiring QCP/SqnSP escorts fall in five paces to the left of the last flight, facing the front with a four pace interval between them.

UNCLASSIFIED

NZAP 2.4 Manual of Ceremonial and Drill

Version 6.00

Part 4 - Queen's Colour and Squadron Standard Ceremonial Drill

13 June 2023

Chapter 4 – Presentation, Handing Over and Laying-up of Queen's Colour or Squadron Standard

- (c) The receiving and retiring QCB/SqnSBs march on with the escort squadron officers, following the last flight's supernumerary officer, and take up position (between the QC/SqnS escorts) by the shortest route, halt and turn about with the squadron officers.
 - (d) The retiring QCB/SqnSB carries the cased QC/SqnS onto the parade at the shoulder.
 - (e) The band falls in 10 paces to the right of No. 2 Flight.
- b. Fall-in procedure—
- (1) After falling the squadron in, the SWO hands the squadron over to the PADJ and retires from the parade.
 - (2) The fall-in procedure continues as shown in Table [4-4-2](#).

Table 4-4-2 Fall-in Procedure for Handover of Queens Colour/Squadron Standard

| Serial | Commander | Command | Action |
|--------|-----------|--|--|
| 1 | PADJ | OFFICERS WILL DRAW SWORDS DRAW – SWORDS FALL IN THE – OFFICERS | <ul style="list-style-type: none"> – Officers carry out the normal procedure laid down for squadron drill. – The adjutant hands over to the PCDR and retires from the parade. |
| 2 | PCDR | PARADE PARADE – SHUN MOVE TO THE RIGHT IN COLUMN OF THREES RIGHT – TURN | <ul style="list-style-type: none"> – The squadron, led by the band, moves off as in squadron drill. – The receiving QCP/SqnSP steps off with the last flights. – The retiring QCP/SqnSP steps off with No.3 Flight. |

- c. Procedure on arrival at the parade ground—
- (1) When the squadron approaches the parade ground, the retiring QCP/SqnSP disengages and moves to a position on the right hand side of the parade ground in line with the saluting base facing the parade. Normal wheels may be executed.
 - (2) When the squadron has reached the position it is to occupy on the parade ground, the procedure for handing over the QC/SqnS continues as is shown in Table [4-4-3](#).

UNCLASSIFIED

NZAP 2.4 Manual of Ceremonial and Drill

Version 6.00

Part 4 - Queen's Colour and Squadron Standard Ceremonial Drill

13 June 2023

Chapter 4 – Presentation, Handing Over and Laying-up of Queen's Colour or Squadron Standard

Table 4-4-3 Procedure for the Handover of Queens Colour/Squadron Standard

| Serial | Commander | Command | Action |
|--------|------------------------------------|--|--|
| 1 | PCDR | SQUADRON – HALT SQUADRON WILL ADVANCE LEFT – TURN | <ul style="list-style-type: none"> – The receiving QCP/SqnSP, on the command 'LEFT – TURN' – – executes a normal wheel to face the front; – marches out in quick time; and – takes up position six paces in front of and in the centre of No.1 Flight, facing the saluting base. – The QCP/SqnSP (receiving or retiring) may execute all restricted turns by normal wheels, including march to a place of parade. – All other turns after the form up and positioning are carried out using pivot wheels. – The pivot wheel is to be carried out in eight paces starting with the left foot. – If halted after a wheel, this is done on the eighth pace, but if moving forward in a new direction the party steps out with the left foot. – The knees are to be raised as for marking time and the arms are to be held by the side during wheels. |
| 2 | PCDR | OFFICERS WILL TAKE POST IN REVIEW ORDER OUTWARDS – TURN QUICK – MARCH | |
| 3 | When the officers are in position— | | |
| | PCDR | LEFT – TURN SQUADRON FORM TWO – RANKS WITHOUT INTERVAL IN OPEN ORDER RIGHT – DRESS EYES – FRONT STAND AT – EASE | <ul style="list-style-type: none"> – The squadron is now formed up as a squadron in line at open order. – The band, after leading the squadron onto the parade ground— <ul style="list-style-type: none"> – takes up a position ten paces to the rear of the squadron, directly behind No.2 Flight; and – stands at ease. |

UNCLASSIFIED

NZAP 2.4 Manual of Ceremonial and Drill

Version 6.00

Part 4 - Queen's Colour and Squadron Standard Ceremonial Drill

13 June 2023

Chapter 4 – Presentation, Handing Over and Laying-up of Queen's Colour or Squadron Standard

| Table 4-4-3 Procedure for the Handover of Queens Colour/Squadron Standard (cont.) | | | |
|--|--|---|--|
| Serial | Commander | Command | Action |
| 4 | PCDR | SQUADRON SQUADRON – SHUN RECEIVING AND RETIRING COLOUR PARTIES – TAKE POST | <ul style="list-style-type: none"> – The receiving QCP/SqnSP, under the orders of the receiving QCB/SqnSB, marches out to a position 15 paces from the saluting base facing left. – The retiring QCP/SqnSP, under the orders of the retiring QCB/SqnSB, marches out to a position seven paces from the receiving QCP/SqnSP and halts facing them. – Movements of both receiving and retiring QCP/SqnSPs are coordinated, using drum beats. – At the same time the QC/SqnS orderly takes up position at Point A (refer to Figure 3-1-1). |
| 5 | PCDR | UNCASE THE QUEEN'S COLOUR SQUADRON PRESENT – ARMS | <ul style="list-style-type: none"> – The QC/SqnS escorts of both QCP/SqnSPs make a three quarter about turn alternatively left and right so that they face outwards from the QC/SqnS. – At the same time the QC/SqnS escorts of both QCP/SqnSPs bring their rifles to the position of 'on guard'. – The receiving QCB/SqnSB salutes with the sword. – As soon as the last movement of the 'PRESENT' is completed, the QC/SqnS W/O moves by the left flank of the receiving QCP/SqnSP and assists in uncasing the QC/SqnS. – After the QC/SqnS has been uncased and the QCB/SqnSB has brought the QC/SqnS to order, the QC/SqnS W/O salutes, turns right, moves to a position one pace from the QC/SqnS orderly, halts and hands the case to the orderly, then resumes their original position, where, after halting, they draw their sword. – The QC/SqnS orderly, on receiving the case, turns about and marches off the parade ground. |
| 6 | Immediately the QC/SqnS orderly has marched off and the QC/SqnS W/O has drawn their sword— | | |
| | PCDR | SQUADRON SHOULDER ARMS | <ul style="list-style-type: none"> – The QC/SqnS escorts— <ul style="list-style-type: none"> – turn to face inwards; and – assume the position of shoulder arms |

UNCLASSIFIED

UNCLASSIFIED

NZAP 2.4 Manual of Ceremonial and Drill

Version 6.00

Part 4 - Queen's Colour and Squadron Standard Ceremonial Drill

13 June 2023

Chapter 4 – Presentation, Handing Over and Laying-up of Queen's Colour or Squadron Standard

| Table 4-4-3 Procedure for the Handover of Queens Colour/Squadron Standard (cont.) | | | |
|--|---------------------|--|--|
| Serial | Commander | Command | Action |
| 7 | PCDR | HAND OVER THE QUEEN'S COLOUR | <ul style="list-style-type: none"> - The receiving QCB/SqnSB— - returns their sword; then - reports— <i>'Flight Lieutenant..... and Colour Party of RNZAF Base</i> - The retiring QCB/SqnSB— - takes four paces forward; and - brings the QC/SqnS to the carry. - The receiving QCB/SqnSB— - moves forward; and - grasps the QC/SqnS pike. - The retiring QCB/SqnSB says— <i>'I give into your safe keeping the Queen's QC/SqnS of the Royal New Zealand Air Force, I charge you to guard and defend it.'</i> - The receiving QCB/SqnSB replies— <i>'I will do so.'</i> - The retiring QCB/SqnSB relinquishes hold of the QC/SqnS. - The receiving QCB/SqnSB— - resumes their original position by stepping back three paces; then - brings the QC/SqnS to order. - The retiring QCB/SqnSB— - takes four paces to the rear; - draws their sword; and - salutes. |
| 8 | PCDR | MARCH ON THE QUEEN'S COLOUR SQUADRON PRESENT – ARMS | <ul style="list-style-type: none"> - The receiving QCB/SqnSB brings the QC/SqnS to the carry. - The band plays Point of War. |
| 9 | Receiving QCB/SqnSB | COLOUR PARTY LEFT WHEEL QUICK – MARCH | <ul style="list-style-type: none"> - The receiving QCB/SqnSB, in quick time by a series of wheels— - moves to a position six paces in front of and in centre of No.2 Flight; - halts; - turns about; and - faces the saluting base. - As the receiving QCB/SqnSB steps off, the band plays the RNZAF March. |

UNCLASSIFIED

NZAP 2.4 Manual of Ceremonial and Drill

Version 6.00

Part 4 - Queen's Colour and Squadron Standard Ceremonial Drill

13 June 2023

Chapter 4 – Presentation, Handing Over and Laying-up of Queen's Colour or Squadron Standard

| Table 4-4-3 Procedure for the Handover of Queens Colour/Squadron Standard (cont.) | | | |
|--|---|--|---|
| Serial | Commander | Command | Action |
| 10 | As the receiving QCP/SqnSP moves clear— | | |
| | Retiring QCB/ SqnSB | RETIRING COLOUR PARTY QUICK – MARCH | <ul style="list-style-type: none"> – The retiring QCP/SqnSP— – steps off (in step with the receiving QCP/SqnSP); – marches straight ahead until clear of the right flank of the escort squadron; – wheels off the parade ground; and – is dismissed by the retiring QCB/SqnSB. |
| 12 | PCDR | SQUADRON SHOULDER – ARMS SQUADRON WILL MOVE TO THE LEFT/RIGHT IN THREES LEFT/RIGHT TURN BY THE LEFT/RIGHT QUICK – MARCH | <ul style="list-style-type: none"> – The QC/SqnS is marched by the escort squadron to the officers mess and lodged with due ceremony or to the designated area where the QC/SqnS is normally secured. |

*Section 3 – Laying-up of the Queen's Colour/Squadron Standard***4.4.5 Order of service**

- a. The following order of service for the laying up of QC/SqnSs can be incorporated in the Service of Matins or Evensong and, if the authorities of the church concerned agree, should follow the Third Collect.
- b. During the service preceding the ceremony, the QCP/SqnSP is to remain at the back of the church.
- c. The senior officer detailed to hand over the QC/SqnS is to be seated at the inside end of the right hand front pew.
 - (1) At the beginning of the last verse of the hymn preceding the ceremony, the QCP/SqnSP, under arms and wearing headdress, forms up with the QC/SqnS at the west end of the church.
 - (2) At the end of the hymn, the RNZAF band plays the RNZAF March and the QCP/SqnSP, with the QC/SqnS at the carry, move forward in slow time and halts two paces from the chancel steps.
 - (3) The senior officer, without headdress, moves to the foot of the chancel steps, facing the QCP/SqnSP.
 - (4) When the QCP/SqnSP reaches their position, the dignitary or incumbent comes to the chancel steps and says—

'It is an ancient and laudable custom to lay up in the House of God the consecrated emblems of a person's duty and service, there to remain for all time as a reminder of duty well done and of the strength that God supplies.'

- (5) The senior officer is then to takes the QC/SqnS and, turning about, says to the dignitary or incumbent—

'*..... Sir/Ma'am, I ask you to receive the Queen's Colour/Squadron Standard for +..... for safe lodging in the House of God until such time as it shall rest like those whose courage and devotion are enshrined in its story.'

* Very Reverend, Reverend, or Venerable

+ Unit

- (6) The dignitary or incumbent replies—

'We receive their QC/SqnS into the safe keeping of God's House, here to hang for all time as a reminder to those who pass by their duty to God, to their Sovereign, and to their country.'

- (7) The QCP/SqnSP is to presents arms, the officer saluting.

- (8) The dignitary or incumbent, followed by the senior officer, proceeds to the altar rails where they receive the QC/SqnS from the officer and lay it upon the Holy Table.

- (9) The senior officer is then to turns about to resumes their seat.

- (10) As they turn about the QCP/SqnSP is to shoulders arms.

- (11) The dignitary or incumbent will then say the following prayer—

'Almighty and Everlasting God, giver of all strength and grace, and Captain of our Salvation, we offer in this Thy House the symbol of faithfulness. May Thy blessing rest on those who have borne it unsullied through the years, and may it ever remain a sign of that unity which springs from the acceptance of Thy grace, who are with the Son and the Holy Ghost, one God, world without end. Amen.'

- (12) After their prayer the National Anthem is to be played and the QCP/SqnSP is to present and shoulder arms on the first and last notes respectively.

- (13) The QCP/SqnSP is to move to a side aisle before the choir and clergy leave the chancel.

- (14) While the clergy are leaving it would be suitable for the hymn 'He Who Would Valiant Be' to be sung.

*Section 4 – Alternative procedure for the ceremony of parading the Queens
Colour/Squadron Standard*

4.4.6 General

- a. This procedure may be carried out indoors in the event of wet weather.
- b. The strength of the parade to carry out their ceremony is to be of a minimum of—
 - (1) one PCDR;
 - (2) three FLTCDRs; and
 - (3) three flights of 33 SNCOs/junior ranks (JRs).

4.4.7 Parade form up

QCP/SqnSP

- (1) The squadron is to be paraded at a predetermined location, sized and inspected as for normal squadron drill. (Refer to Part 2, [Chapter 3](#).)
- (2) When the inspection is completed, the squadron, led by the band—
 - (a) marches on to the review parade ground;
 - (b) forms up in line of flights; and
 - (c) stands at ease.
- (3) The band takes up position in the centre and to the rear of the parade.

4.4.8 Parade procedure.

- a. The alternative wet weather procedure for parading the QC/SqnS is shown in Table [4-4-4](#).

UNCLASSIFIED

NZAP 2.4 Manual of Ceremonial and Drill

Version 6.00

Part 4 - Queen's Colour and Squadron Standard Ceremonial Drill

13 June 2023

Chapter 4 – Presentation, Handing Over and Laying-up of Queen's Colour or Squadron Standard

Table 4-4-4 Procedure for Indoor Handover of Queen's Colour/Squadron Standard

| Serial | Commander | Command | Action |
|--------|--|---|--|
| 1 | PCDR | PARADE PARADE – SHUN FORM – TWO RANKS WITHOUT INTERVALS IN OPEN ORDER – RIGHT – DRESS EYES – FRONT OFFICERS TAKE POST IN REVIEW ORDER RIGHT – TURN QUICK – MARCH LEFT – TURN | <ul style="list-style-type: none"> – Officers act as detailed in the review of a wing. – The QC/SqnS, which is positioned at the extreme left flank of the parade, is marched on. |
| 2 | PCDR | MARCH ON THE QUEEN'S COLOUR PRESENT – ARMS | <ul style="list-style-type: none"> – The QC/SqnS is marched on under orders of the QCB/SqnSB. |
| 3 | When the QC/SqnS is in position in front of No.2 Flight of the squadron— | | |
| | PCDR | SHOULDER – ARMS STAND AT – EASE | <ul style="list-style-type: none"> – The parade is now ready to receive the reviewing officer. |
| 4 | When the reviewing officer and their party approach the parade ground— | | |
| | PCDR | PARADE PARADE – SHUN | |
| 5 | The reviewing officer, escorted by the Chief of Air Force (CAF) or their representative and the base commander (BCDR), mount the dais where they will take up position to the centre front of the dais with the attending party at the rear. | | |
| 6 | When the reviewing officer has taken up their position— | | |
| | PCDR | ROYAL/GENERAL SALUTE PRESENT – ARMS | <ul style="list-style-type: none"> – The band plays the appropriate salute. |
| 78 | PCDR | SHOULDER – ARMS | <ul style="list-style-type: none"> – The PCDR marches out to the saluting base and reports to the reviewing officer— <i>'Parade ready for your inspection, Sir/ Ma-am'</i> – The reviewing officer inspects the parade. – The reviewing officer will be accompanied on the inspection by the PCDR and followed by CAF or their representative and the BCDR. – During the inspection, the band plays appropriate music. – At the conclusion of the inspection the inspecting party will return to the saluting base, where the PCDR requests permission to carry on. |

UNCLASSIFIED

NZAP 2.4 Manual of Ceremonial and Drill

Version 6.00

Part 4 - Queen's Colour and Squadron Standard Ceremonial Drill

13 June 2023

Chapter 4 – Presentation, Handing Over and Laying-up of Queen's Colour or Squadron Standard

| Table 4-4-4 Procedure for Indoor Handover of Queen's Colour/Squadron Standard (cont.) | | | |
|--|------------------|--|--|
| Serial | Commander | Command | Action |
| 8 | PCDR | PARADE THE QUEEN'S COLOUR COLOUR PARTY TAKE – POST | <ul style="list-style-type: none"> – The QCP/SqnSP, under the orders of the QCB/SqnSB— – marches out five paces towards the saluting base; – wheels left; and – marches along the front of the line of flights. – When the QCP/SqnSP reaches a position equal to the frontage of half a flight from the left of the line, they left wheel. – On reaching a position in line with the officers in the line of flights, the QCP/SqnSP— – executes a further left wheel; and – halts when seven paces from the left flank of the last flight. |
| 9 | QCB/SqnSB | TAKE – POST | <ul style="list-style-type: none"> – The QCP/SqnSP— – takes one pace to the rear, right; – turns; and – moves to position as follows— <ul style="list-style-type: none"> – QC/SqnS W/O. In rear of rear rank opposite left file. – QC/SqnS. Between front and rear rank in line with left file. – QCB/SqnSB. Between officer rank and front rank opposite left file. |
| 10 | PCDR | PARADE PRESENT – ARMS COLOUR PARTY BY THE CENTRE SLOW – MARCH | <ul style="list-style-type: none"> – The band plays a slow march. – The QCP/SqnSP marches through the line of flights. – When the QC/SqnS has cleared the right flank of No.1 Flight— <ul style="list-style-type: none"> – the band ceases playing; and – the QCP/SqnSP halts. |
| 11 | PCDR | PARADE SHOULDER – ARMS | |
| 12 | QCB/SqnSB | ESCORTS TAKE – POST | <ul style="list-style-type: none"> – The escorts reform on the QC/SqnS. |
| 13 | QCB/SqnSB | COLOUR PARTY BY THE CENTRE QUICK – MARCH CHANGE DIRECTION LEFT LEFT – WHEEL | <ul style="list-style-type: none"> – When the QCP/SqnSP reaches a designated march past line, they wheel left. |

UNCLASSIFIED

NZAP 2.4 Manual of Ceremonial and Drill

Version 6.00

Part 4 - Queen's Colour and Squadron Standard Ceremonial Drill

13 June 2023

Chapter 4 – Presentation, Handing Over and Laying-up of Queen's Colour or Squadron Standard

| Table 4-4-4 Procedure for Indoor Handover of Queen's Colour/Squadron Standard (cont.) | | | |
|--|-------------------------------------|---|---|
| Serial | Commander | Command | Action |
| 14 | QCB/SqnSB | COLOUR PARTY BREAK INTO SLOW TIME SLOW – MARCH | <ul style="list-style-type: none"> – The QCP/SqnSP marches past in slow time. – On the command 'SLOW – MARCH' the band is starts to play a slow march. – When the QCP/SqnSP reaches Point C, the QCB/SqnSB is to let fly (or lower) the QC/SqnS, as appropriate. – When the QCP/SqnSP reaches Point D the QCB/SqnSB is to catch (or raise) the QC/SqnS. – When the QCP/SqnSP reaches a position fifteen paces from Point D, the band stops playing. |
| 15 | QCB/SqnSB | COLOUR PARTY – HALT BY THE CENTRE QUICK – MARCH CHANGE DIRECTION LEFT LEFT – WHEEL | <ul style="list-style-type: none"> – The QCP/SqnSP marches towards the line of flights, and when they reach a point in line with their original position, they wheel left and take up their position ten paces in front of the centre of the line. |
| 16 | After the QCP/SqnSP is in position— | | |
| | PCDR | SQUADRON WILL ADVANCE IN REVIEW ORDER BY THE CENTRE QUICK – MARCH | <ul style="list-style-type: none"> – On the command, the entire parade marches forward 15 paces (seven paces if in a hangar) and halts. – The band plays the Advance in Review Order. |
| 17 | PCDR | GENERAL/ROYAL SALUTE PRESENT – ARMS SHOULDER – ARMS | <ul style="list-style-type: none"> – The reviewing officer addresses the parade. – At the conclusion of the address, the official car(s) draws up to the dais. – The squadron is brought to attention. – As the wheels of the official car(s) begin to roll, the squadron will accord the reviewing officer a Royal/general salute. <p>Note: If the parade is being held in a hangar, the squadron salutes as the reviewing officer leaves the parade on foot.</p> |

Chapter 5 – King's Birthday Parade with Queen's Colour Handover

Section 1 – Outdoor parade procedures

4.5.1 Introduction

- a. The parade is to consist of
 - (1) an armed escort squadron;
 - (2) retiring Queens' Colour party (QCP);
 - (3) receiving QCP;
 - (4) unarmed support squadrons; and
 - (5) the base band.
- b. The parade will follow the following format—
 - (1) Assembly and march on of support squadrons.
 - (2) Assembly and march on of escort squadron and receiving/retiring QCPs.
 - (3) Reception of reviewing officer.
 - (4) Inspection of escort squadron.
 - (5) Hand over of the QC.
 - (6) Showing of the QC.
 - (7) Advance in review order.
 - (8) Honouring of the Sovereign's birthday.
 - (9) March past of the escort squadron and dismissal.
 - (10) Ceremony of Beating Retreat.
 - (11) Departure from the parade ground of the reviewing officer and party.
 - (12) March off and dismissal of the support squadrons.
 - (13) Lodging of the QC by No.1 Flight of the escort squadron, accompanied by the band.

UNCLASSIFIED

NZAP 2.4 Manual of Ceremonial and Drill
 Part 4 - Queen's Colour and Squadron Standard Ceremonial Drill
 Chapter 5 – King's Birthday Parade with Queen's Colour Handover

Version 6.00
 13 June 2023

4.5.2 Parade form up procedure

a. Table [4-5-1](#) gives an outline of the parade form up procedure.

Table 4-5-1 Form Up for King's Birthday Parade with Queen's Colour Handover

| Serial | Commander | Command | Action |
|--|-----------|--|--|
| Assembly and march on of support squadrons | | | |
| 1 | | | Support squadrons fall in at their predetermined squadron assembly areas and march onto the parade ground independently in column of route. |
| 2 | PCDR | NO... SQUADRON HALT SQUADRON WILL ADVANCE LEFT – TURN RIGHT DRESS | |
| Assembly and march on of escort squadron | | | |
| 3 | | | <ul style="list-style-type: none"> – The escort squadron is to fall in on the squadron assembly area with the base band on the right flank. The normal squadron fall in procedure is to be used (refer to paragraph 2.4.2), with the following additions— – The receiving QCP escorts fall in five paces to the left of No.1 Flight, facing the front, with a four pace interval between them. – The QC W/O falls in, in line with the rear rank and one pace behind the escorts. – The retiring QCP escorts fall in five paces to the left of last flight facing the front, with a four pace interval between them. – The retiring QC W/O falls in, in line with the rear rank and one pace behind the escorts. – The receiving and retiring QCBs march out with the escort squadron officers following the last flight's supernumerary officers. – When the officers fall in, the receiving and retiring QCBs march to their respective positions between the QCP escorts by the shortest route. – The band falls in 10 paces to the right of No.1 Flight. – The retiring QCB carries the cased QC onto the parade ground at the shoulder. – After falling the squadron in, the squadron warrant officer SWO hands over to the SADJ in the normal way. |

UNCLASSIFIED

NZAP 2.4 Manual of Ceremonial and Drill

Version 6.00

Part 4 - Queen's Colour and Squadron Standard Ceremonial Drill

13 June 2023

Chapter 5 – King's Birthday Parade with Queen's Colour Handover

| Tables 4-5-1 Form Up for King's Birthday Parade with Queen's Colour Handover (cont.) | | | |
|---|------------------|--|---|
| Serial | Commander | Command | Action |
| 4 | SADJ | OFFICER WILL DRAW SWORDS DRAW – SWORDS FALL IN THE OFFICERS | <ul style="list-style-type: none"> – The officers carry out the normal fall in procedure (refer to paragraph 2.4.2). – When the QCBs are in their respective positions, the SADJ— <ul style="list-style-type: none"> – hands over to the PCDR; – then turns right: and – marches into position in front of No.1 Flight marker. – The escort squadron, led by the base band, marches on in column of route. – As the squadron approaches the parade ground, the retiring QCP— <ul style="list-style-type: none"> – disengages and – moves to a position on the right hand side of the parade ground, in line with the saluting base and facing the parade. – As the squadron approaches the position it is to occupy on the parade ground, the band— <ul style="list-style-type: none"> – wheels right; and – counter marches into its position centrally behind the escort squadron. |
| 5 | ESCDR | ESCORT SQUADRON – HALT SQUADRON WILL ADVANCE LEFT – TURN | <ul style="list-style-type: none"> – On the command 'LEFT – TURN', the receiving QCP— <ul style="list-style-type: none"> – pivot wheels to face the front; and – marches out in quick time to take up a position six paces in front of, and in the centre of No.1 Flight, facing the saluting base. <p>Note: The QCP executes all restricted turns by pivot wheeling. All other turns are carried out using the normal wheel.</p> |
| 6 | ESCDR | IN OPEN ORDER – RIGHT DRESS EYES – FRONT STAND AT – EASE | <ul style="list-style-type: none"> – The PADJ takes up position. |
| 7 | PADJ | PARADE PARADE – SHUN | <ul style="list-style-type: none"> – Escort and support squadrons act as the rest of the parade. – The PADJ hands over to the PCDR. |
| 8 | PCDR | OFFICERS WILL TAKE POST IN REVIEW ORDER OUTWARDS – TURN QUICK MARCH | <ul style="list-style-type: none"> – Officers— <ul style="list-style-type: none"> – march out; and – take up their respective positions. |

UNCLASSIFIED

NZAP 2.4 Manual of Ceremonial and Drill
 Part 4 - Queen's Colour and Squadron Standard Ceremonial Drill
 Chapter 5 – King's Birthday Parade with Queen's Colour Handover

Version 6.00
 13 June 2023

| Tables 4-5-1 Form Up for King's Birthday Parade with Queen's Colour Handover (cont.) | | | |
|---|---|---|--|
| Serial | Commander | Command | Action |
| 9 | When the officers of all squadrons are in position— | | |
| | PCDR | LEFT – TURN PARADE RIGHT DRESS | – All squadrons act in together. |
| 10 | PCDR | EYES – FRONT STAND AT – EASE | <ul style="list-style-type: none"> – The PADJ's position is two paces to the right rear of the PCDR for their parade only. – The SWOs are to dress each rank of their own squadrons. |
| <p>The parade is now formed up as a hollow square of support squadrons in line at close order, around an escort squadron formed up as a squadron in line at open order.</p> <ul style="list-style-type: none"> a. Personnel constraints may dictate that only two support squadrons are feasible. b. The band is positioned 10 paces in rear and centre of the escort squadron and is to be stood at ease. c. The ESCDR is positioned 10 paces in front centre of the squadron. d. The PCDR is six paces in front of the ESCDR. | | | |

4.5.3 Reception of the reviewing officer

The procedure for the reception of the reviewing officer is shown in Table [4-5-2](#).

Table 4-5-2 Procedure for the Reception of the Reviewing Officer

| Serial | Commander | Command | Action |
|---------------|--|--|--------------------------------------|
| 1 | When the reviewing officer approaches— | | |
| | PCDR | PARADE PARADE – SHUN | |
| 2 | When the reviewing officer is in position on the dais— | | |
| | PCDR | GENERAL SALUTE PRESENT – ARMS | – The band plays the general salute. |
| 3 | PCDR | SHOULDER – ARMS | |

4.5.4 Inspection of the escort squadron

- a. The PCDR approaches the dais and invites the reviewing officer to inspect the escort squadron.
- b. After the inspection, the inspection party returns to the saluting base and the PCDR requests permission from the reviewing officer to hand over the QC.
- c. On receiving permission, the PCDR salutes and returns to their position.

4.5.5 Handing over the Queen's Colour

The procedure for handing over the QC is shown in Table [4-5-3](#).

Table 4-5-3 Procedure for Handover of the Queen's Colour/Squadron Standard

| Serial | Commander | Command | Action |
|--------|-----------|--|---|
| 1 | PCDR | RECEIVING AND RETIRING COLOUR PARTIES TAKE POST | <ul style="list-style-type: none"> – The receiving QCP, under the orders of the receiving QCB, marches out to a position 15 paces from the saluting base, facing left. – The retiring QCP, under the orders of the retiring QCB, marches out to a position seven paces from the receiving QCP and halts facing them. – Movements of both QCPs are coordinated using drum beats. – The QCO takes up position independently. |
| 2 | PCDR | UNCASE THE QUEEN'S COLOUR PARADE – PRESENT – ARMS | <ul style="list-style-type: none"> – The QC escorts of both QCPs— <ul style="list-style-type: none"> – make a three quarter about turn alternative left and right, so that they face outwards from the QC; and – at the same time, bring their rifles to the 'on guard' position. – The receiving QCB salutes with the sword. – As soon as the last movement of the 'PRESENT' is completed, the retiring QC W/O moves via the right flank of the retiring QCP and assists in the uncasing of the QC. They drape the case over the left arm. – At the same time the QCO moves into position to await the case. – After the QC has been uncased and the QCB has brought the QC to order, the retiring QC W/O— <ul style="list-style-type: none"> – salutes; – turns right; – moves to a position one pace from the QCO; – halts; – hands the case to the QCO; – - turns; – takes up their original position; – halts; and – draws their sword. – The receiving QC W/O draws their sword at the same time as the retiring QC W/O draws theirs. – The QCO, on receiving the case— <ul style="list-style-type: none"> – salutes; – turns; and – marches off the parade ground. |

UNCLASSIFIED

NZAP 2.4 Manual of Ceremonial and Drill
 Part 4 - Queen's Colour and Squadron Standard Ceremonial Drill
 Chapter 5 – King's Birthday Parade with Queen's Colour Handover

Version 6.00
 13 June 2023

| Table 4-5-3 Procedure for Handover of the Queen's Colour/Squadron Standard (cont.) | | | |
|---|------------------|--|--|
| Serial | Commander | Command | Action |
| 3 | PCDR | PARADE SHOULDER – ARMS | <ul style="list-style-type: none"> – The QC escorts— <li style="padding-left: 20px;">– turn and face inwards; and <li style="padding-left: 20px;">– at the same time, assume the position of shoulder arms. – The receiving QCB brings the QC to the carry on the command 'SHOULDER ARMS'. |
| 4 | PCDR | HAND OVER THE QUEEN'S COLOUR | <p>The receiving QCB—</p> <ul style="list-style-type: none"> – returns their sword; and – reports— <i>'Flight Lieutenant and Queen's Colour party of RNZAF Base</i>' – The retiring and receiving QCBs each take three paces forward. – The QC is brought to the carry. – The receiving QCB— <ul style="list-style-type: none"> – - moves forward; and – - grasps the QC pike. – The retiring QCB says— <i>'I give into your safe keeping the Queen's Colour of the Royal New Zealand Air Force.'</i> <i>'I charge you to guard and defend it.'</i> – The receiving QCB responds— <i>'I will do so.'</i> – The retiring QCB relinquishes their hold on the QC. – The receiving QCB— <ul style="list-style-type: none"> – - resumes their original position by stepping back three paces; and – - brings the QC to order. – At the same time, the retiring QCB— <ul style="list-style-type: none"> – - takes three paces to the rear; – - draws their sword; and – - salutes. |
| 5 | PCDR | MARCH ON THE QUEEN'S COLOUR PARADE PRESENT – ARMS | <ul style="list-style-type: none"> – The band plays Point of War on the command 'PRESENT ARMS'. |

UNCLASSIFIED

NZAP 2.4 Manual of Ceremonial and Drill

Version 6.00

Part 4 - Queen's Colour and Squadron Standard Ceremonial Drill

13 June 2023

Chapter 5 – King's Birthday Parade with Queen's Colour Handover

| Table 4-5-3 Procedure for Handover of the Queen's Colour/Squadron Standard (cont.) | | | |
|---|---|---|---|
| Serial | Commander | Command | Action |
| 6 | At the conclusion of the playing of Point of War— | | |
| | Receiving QCB | COLOUR PARTY LEFT WHEEL QUICK – MARCH | <ul style="list-style-type: none"> – The QCP move in quick time, by a series of wheels, to a position six paces in front of the centre of the escort squadron, facing the dais. – The band plays the RNZAF March. – The retiring QCP— <ul style="list-style-type: none"> – presents arms with the parade; and – holds the present until the receiving QCP has passed their front. |
| 7 | When the receiving QCP has passed the retiring QCP— | | |
| | Retiring QCB | RETIRING COLOUR PARTY SHOULDER – ARMS QUICK MARCH | <ul style="list-style-type: none"> – The retiring QCP— <ul style="list-style-type: none"> – marches in step with the receiving QCP, moving straight ahead until they are clear of the parade ground; then – halt; and – is dismissed by the retiring QCB. |
| 8 | When the receiving QCP is in position— | | |
| | PCDR | PARADE SHOULDER – ARMS PARADING THE QUEEN'S COLOUR | |

UNCLASSIFIED

4.5.6 Parading the Queen's Colour

The procedure for parading the QC is shown in Table [4-5-4](#).

Table 4-5-4 Procedure for Parading the Queen's Colour

| Serial | Commander | Command | Action |
|--------|--|---|--|
| 1 | PCDR | PARADE | |
| 2 | When the reviewing officer is in position on the dais— | | |
| | PCDR | PARADE THE QUEEN'S COLOUR COLOUR PARTY TAKE POST | <ul style="list-style-type: none"> – The QCP, under the command of the QCB— – executes a fixed pivot left wheel; and – marches along the front of the flights. – When the QC clears the left flank of the escort squadron, the QCP again— – executes a left fixed pivot wheel; – on reaching a position in line with the officers in the line of flights, executes a further left fixed pivot wheel; and – halts. |
| 3 | QCB | COLOUR PARTY TAKE POST | <ul style="list-style-type: none"> – The QCP— – takes one pace to the rear; – turns right; and – moves to the following positions— – QC W/O - to the rear of rear rank in line with left file. – QC - between centre front and centre rear ranks respectively in line with the left file. – QCB - between the officer rank and front rank, in line with left file. |
| 4 | PCDR | ESCORT SQUADRON PRESENT – ARMS | <ul style="list-style-type: none"> – Officers of the support squadron pay compliments. |
| 5 | QCB | COLOUR PARTY BY THE LEFT SLOW – MARCH | <ul style="list-style-type: none"> – The band plays a suitable march – The QCP— – marches through the line of flights; – halts when the QCP is clear of the right flank of No.1 Flight; – reforms on the QCB; and – marches along the front of the support squadron, facing the dais. |
| 6 | PCDR | ESCORT SQUADRON SHOULDER – ARMS | <ul style="list-style-type: none"> – Support squadron officers act on this command. |

UNCLASSIFIED

UNCLASSIFIED

4.5.7 Advance in review order

The procedure for the advance in review order is shown in Table [4-5-5](#).

Table 4-5-5 Procedure for the Advance in Review Order

| Serial | Commander | Command | Action |
|--------|-----------|---|--|
| 1 | PCDR | ESCORT SQUADRON IN CLOSE ORDER – RIGHT – DRESS EYES – FRONT ESCORT SQUADRON WILL ADVANCE IN REVIEW ORDER BY THE CENTRE – QUICK – MARCH | <ul style="list-style-type: none"> – The squadron— – moves forward 15 paces; and – halts. |
| 2 | PCDR | GENERAL SALUTE PRESENT – ARMS SHOULDER – ARMS | |

4.5.8 Honouring the Sovereign's birthday

The procedure for honouring the sovereign's birthday is shown in Table [4-5-6](#).

Table 4-5-6 Procedure for Honouring the Sovereign's Birthday

| Serial | Commander | Command | Action |
|--------|---|--|---|
| 1 | | | – The reviewing officer and their party move from the dais to a position in front, of the parade, turn about and face the dais. |
| 2 | PCDR | ROYAL SALUTE PRESENT – ARMS | <ul style="list-style-type: none"> – The band plays the first verse of British Nation Anthem. – At the same time the sovereign's personal flag for New Zealand is broken at the masthead above the dais. |
| 3 | PCDR | PARADE SHOULDER – ARMS PARADE WILL REMOVE HEADDRESS REMOVE – HEADDRESS | <p>Notes—</p> <ol style="list-style-type: none"> 1. The QCP is not to act on this command. 2. Officers and other ranks are to remove their headdress with their left hand. 3. Bands people remove their headdress with their right hand. |
| 4 | The PCDR leads three cheers for His Majesty The King— | | |
| | PCDR | THREE CHEERS FOR HIS/HER MAJESTY THE KING/QUEEN HIP, HIP – HURRAY HIP, HIP – HURRAY HIP, HIP – HURRAY | Note: Hats are to be raised to their full extent of the arm with each cheer. |

UNCLASSIFIED

UNCLASSIFIED

NZAP 2.4 Manual of Ceremonial and Drill
 Part 4 - Queen's Colour and Squadron Standard Ceremonial Drill
 Chapter 5 – King's Birthday Parade with Queen's Colour Handover

Version 6.00
 13 June 2023

| Table 4-5-6 Procedure for Honouring the Sovereign's Birthday (cont.) | | | |
|---|--|---|--|
| Serial | Commander | Command | Action |
| 5 | PCDR | PARADE WILL REPLACE HEADDRESS REPLACE HEADDRESS PARADE STAND AT – EASE | <ul style="list-style-type: none"> – The reviewing officer moves back to the dais. – The PCDR takes position beside the dais. – The reviewing officer addresses the parade. |
| 6 | At the conclusion of the address, the PCDR resumes position on the parade. | | |
| | PCDR | PARADE PARADE – SHUN OFFICERS WILL TAKE POST LEFT TURN QUICK MARCH INWARDS – TURN | |

4.5.9 March past of the escort squadron

The procedure for the march past of the escort squadron is shown in Table [4-5-7](#).

Table 4-5-7 March Past of the Escort Squadron

| Serial | Commander | Command | Action |
|---------------|---|--|---------------|
| 1 | PCDR | ESCORT SQUADRON WILL MARCH PAST MOVE TO THE RIGHT IN COLUMN OF ROUTE RIGHT – TURN | |
| 2 | When all personnel are in column of route— | | |
| | PCDR | ESCORT SQUADRON BY THE LEFT QUICK – MARCH | |
| 3 | As the squadron approaches the first saluting point— | | |
| | PCDR | BY THE RIGHT COMPLIMENTS WILL BE PAID BY FLIGHTS | |
| 4 | As each FLTCDR arrives abreast of the first saluting point— | | |
| | FLTCDR | NO.... FLIGHT EYES – RIGHT | |

UNCLASSIFIED

NZAP 2.4 Manual of Ceremonial and Drill
 Part 4 - Queen's Colour and Squadron Standard Ceremonial Drill
 Chapter 5 – King's Birthday Parade with Queen's Colour Handover

Version 6.00
 13 June 2023

Table 4-5-7 March Past of the Escort Squadron (cont.)

| Serial | Commander | Command | Action |
|--------|---------------------------------------|---------------------------------------|---|
| 5 | When each flight has passed the dais— | | |
| | FLTCDR | NO.... FLIGHT EYES – FRONT | <ul style="list-style-type: none"> – The escort squadron— <li style="padding-left: 20px;">– marches clear of the parade ground; and <li style="padding-left: 20px;">– halts. – All flights, except No. 1 Flight, march off the parade ground to their respective assembly areas, from where they are dismissed. – No.1 Flight is stood at ease to await the lodging of the QC. |

4.5.10 Beating retreat (optional)

- a. The ceremonial beating retreat is to be carried out by the band and the retreat party as laid down in Part 4, [Chapter 11](#).
- b. The reviewing officer and party dismount the dais at the conclusion of the first verse of *Abide with Me*.
- c. They move on to the parade ground and face the Sovereign's personal flag for New Zealand.

4.5.11 Departure of the reviewing officer.

The procedure for the departure of the reviewing officer is shown in Table [4-5-8](#).

Table 4-5-8 Procedure for the Departure of the Reviewing Officer

| Serial | Commander | Command | Action |
|--------|--|---|--------|
| 1 | At the conclusion of Abide with Me— | | |
| | PCDR | RETREAT PARTY SHOULDER – ARMS | |
| 2 | <ul style="list-style-type: none"> – The reviewing officer's car draws up and the reviewing officer gets in. – As the car doors close— | | |
| | PCDR | RETREAT PARTY GENERAL SALUTE PRESENT – ARMS SHOULDER – ARMS RETREAT PARTY MOVE TO THE LEFT IN FILE LEFT – TURN BY THE CENTRE QUICK – MARCH | |

UNCLASSIFIED

NZAP 2.4 Manual of Ceremonial and Drill
 Part 4 - Queen's Colour and Squadron Standard Ceremonial Drill
 Chapter 5 – King's Birthday Parade with Queen's Colour Handover

Version 6.00
 13 June 2023

4.5.12 March off and dismissal.

- a. The PCDR gives orders for support PCDRs to march their squadrons to their respective assembly areas and to dismiss them.
- b. A period of time must be allowed for invited guests to make their way to the officers' mess for the lodging ceremony.

4.5.13 Lodging the Queen's Colour

- a. **General.** At a convenient time after the parade, the QC will be lodged. This is effected in the officers' mess using the QCP, an escort flight and the band. The actual formation used outside the venue will depend on the ground layout in front of the main entrance of the officers' mess and some flexibility in format must be expected. The parade will form up in column of route in the assembly area and, preceded by the band, will march to the officers' mess where it will be halted adjacent to the main entrance and turned to the front. Once halted, the QCP takes up position in front of the escort flight and opposite the main entrance.
- b. **Lodging procedure.** The procedure for lodging the QC is shown in Table [4.5.9](#).

Table 4-5-9 Procedure for Lodging the Queen's Colour

| Serial | Commander | Command | Action |
|--------|---------------|---|--|
| 1 | Escort FLTCDR | RIGHT – DRESS EYES FRONT MARCH OFF THE QUEEN'S COLOUR PRESENT – ARMS | – The band plays Point of War |
| 2 | QCB | COLOUR PARTY BY THE CENTRE QUICK – MARCH | <ul style="list-style-type: none"> – The QC is carried with the Crown on the Shaft forward. – On entering the foyer, the QCB halts the QCP five paces from the wall bracket. – The QCB— <ul style="list-style-type: none"> – moves forward; – positions the QC in the bracket; – steps back five paces; and – draws their sword. |

UNCLASSIFIED

NZAP 2.4 Manual of Ceremonial and Drill

Version 6.00

Part 4 - Queen's Colour and Squadron Standard Ceremonial Drill

13 June 2023

Chapter 5 – King's Birthday Parade with Queen's Colour Handover

| Table 4-5-9 Procedure for Lodging the Queen's Colour (cont.) | | | |
|---|------------------|----------------------------|--|
| Serial | Commander | Command | Action |
| 3 | QCB | ESCORTS TAKE – POST | <ul style="list-style-type: none"> – The QC escorts— – take three paces forward; – halt; and – inwards about turn. – When they are positioned, the QCB and QC W/O salute. – The QCB— – turns about; and – steps off moving to the right/left of the QC W/O. – The QC W/O wheels around behind the bearer. – The QCB & QC W/O leave the building. – On the last movement of the QCB's about turn, the QC escorts automatically— – order arms; and – stand at ease. |
| 4 | | | <ul style="list-style-type: none"> – When the QC is positioned in the bracket, the escort flight— – shoulder arms; and – proceed together with the band to the assembly area where they are dismissed. |

4.5.14 Sentry change

- (1) On prolonged tours of duty it may be necessary to relieve the QC escorts.
- (2) The QC W/O is to effect any changes.
- (3) The procedure for a sentry change at the Queen's Colour lodging place is shown in Table [4-5-10](#).

Table 4-5-10 Procedure for Changing the Queen's Colour Sentries

| Serial | Commander | Command | Action |
|--------|-----------|---|--|
| 1 | | | <ul style="list-style-type: none"> - The QC W/O and the relieving escorts— - march through the main entrance to the foyer in the same formation as for the QCP; and - halt five paces from the QC. - On their approach, the retiring escorts automatically— - come to attention; and - shoulder arms. - The QC W/O salutes. |
| 2 | QC W/O | RELIEVING ESCORTS TAKE – POST | <ul style="list-style-type: none"> - The relieving escorts— - take three paces forward; - halt; and - inwards about turn. - At the same time, the retiring escorts take one pace left/right close march respectively. - The QC W/O salutes. |
| 3 | QC W/O | RETIRING ESCORTS QUICK – MARCH | <ul style="list-style-type: none"> - The retiring escorts march off. - The QC W/O about turns and steps off when the retiring escorts have passed them. - The relieving escorts— - order arms; and - stand at ease as the retiring escort party quit the area. |

4.5.15 Dislodging the QC.

The procedure for dislodging the QC is shown in Table [4-5-11](#).

Table 4-5-11 Procedure for Dislodging the Queen's Colour

| Serial | Commander | Command | Action |
|--------|-----------|---------------------------------------|---|
| 1 | | | <ul style="list-style-type: none"> - The QCB and the QC W/O— - enter the foyer; and - halt five paces from the QC. - As the QCB and QC W/O halt, the QC escorts automatically— - come to attention; and - shoulder arms. - The QCB and QC W/O salute the QC. - The QCB— - replaces their sword; - moves forward; - removes the QC from the bracket; - dresses the QC at the order; then - turns about. |
| 2 | QCB | COLOUR PARTY QUICK – MARCH | <ul style="list-style-type: none"> - The QC W/O also— - steps off on this command; - passes to the right of the QCB, between the QCB and sentry; and - wheels into position. |
| 3 | | | <ul style="list-style-type: none"> - The QCP marches to the assembly area where the QC is to be cased in the normal manner. - If necessary, once clear of the building the QCB may bring the QC to the carry. |

Section 2 – Alternative Procedures for the Queen's Colour handover parade

4.5.16 Introduction

- a. The alternative parade consists of—
 - (1) an armed escort squadron;
 - (2) receiving QCP;
 - (3) retiring QCP; and
 - (4) the band.
- b. The escort squadron parades with its flights in line on the receiving base.
- c. The band is positioned centrally to the rear of the squadron.
- d. The receiving QCP is positioned centrally in front of No.1 Flight.
- e. The retiring QCP on the left front of the escort squadron.

UNCLASSIFIED

NZAP 2.4 Manual of Ceremonial and Drill
 Part 4 - Queen's Colour and Squadron Standard Ceremonial Drill
 Chapter 5 – King's Birthday Parade with Queen's Colour Handover

Version 6.00
 13 June 2023

4.5.17 Assembly and march on

- a. If weather permits, the escort squadron, receiving QCP and band form up as for the outdoor ceremony.
- b. The retiring QCP does not fall in or march on until the squadron is in position on the receiving base.
- c. The procedure for assembly an march on is shown in Table [4-5-12](#).

Table 4-5-12 Assembly and March on for the Alternative Queen's Colour Parade

| Serial | Commander | Command | Action |
|--------|-----------|---|--|
| 1 | | <ul style="list-style-type: none"> - The PADJ takes over from the PWO. - The PADJ— <ul style="list-style-type: none"> - commands the officers draw swords; - falls the officers in; and - hands the parade over to the PCDR. | |
| 2 | PCDR | MOVE TO THE RIGHT IN COLUMN OF THREES RIGHT – TURN | - The squadron, led by the band, marches onto the parade area. |
| 3 | | On reaching the receiving base— | |
| | PCDR | SQUADRON – HALT SQUADRON WILL ADVANCE LEFT – TURN OFFICERS WILL TAKE POST IN REVIEW ORDER OUTWARDS – TURN QUICK – MARCH OFFICERS LEFT – TURN RIGHT – DRESS EYES – FRONT | |

4.5.18 Wet weather form up

- a. If the weather conditions are such that the forming up outdoors is impossible, the following procedure is adopted.
- b. Flights are initially formed up in line at the predetermined area.
- c. The PWO calls for markers and places them out in line.

4.5.19 Alternative parade procedure

An alternative parade procedure for handing over the Queen's Colour is shown in Table [4-5-13](#).

UNCLASSIFIED

NZAP 2.4 Manual of Ceremonial and Drill
 Part 4 - Queen's Colour and Squadron Standard Ceremonial Drill
 Chapter 5 – King's Birthday Parade with Queen's Colour Handover

Version 6.00
 13 June 2023

Table 4-5-13 Alternative procedure for handing over the Queen's Colour

| Serial | Commander | Command | Action |
|---------------------------------------|---|---|--------|
| 1 | Once the markers are in position— | | |
| | W/O | MARCH ON | |
| 2 | F/Ss, acting independently, march their flights straight to their marker as follows— | | |
| | F/Ss | NO.... FLIGHT NO.... FLIGHT – SHUN BY THE RIGHT QUICK – MARCH NO.... FLIGHT HALT FLIGHT WILL ADVANCE LEFT – TURN | |
| 3 | When all flights are in position— | | |
| | PWO | PARADE RIGHT – DRESS EYES – FRONT | |
| 4 | PWO— – turns about; and – hands over to the PADJ. | | |
| 5 | PADJ— – orders swords to be drawn; – falls in the officers; and – hands the parade over to the PCDR. | | |
| 6 | PCDR | OFFICERS WILL TAKE POST IN REVIEW ORDER OUTWARDS – TURN QUICK – MARCH OFFICERS LEFT – TURN PARADE IN OPEN ORDER RIGHT – DRESS EYES – FRONT STAND AT – EASE | |
| Reception of reviewing officer | | | |
| 7 | As the reviewing officer approaches the parade— | | |
| | PCDR | PARADE PARADE – SHUN | |
| 8 | When the reviewing officer is in position on the dais— | | |
| | PCDR | GENERAL SALUTE PRESENT – ARMS SHOULDER – ARMS | |

UNCLASSIFIED

UNCLASSIFIED

NZAP 2.4 Manual of Ceremonial and Drill

Version 6.00

Part 4 - Queen's Colour and Squadron Standard Ceremonial Drill

13 June 2023

Chapter 5 – King's Birthday Parade with Queen's Colour Handover

| Table 4-5-13 Alternative procedure for handing over the Queen's Colour (cont.) | | | |
|---|---|--|---|
| Serial | Commander | Command | Action |
| Inspection of the parade | | | |
| 9 | The PCDR— <ul style="list-style-type: none"> – approaches the dais; – salutes; and – invites the reviewing officer to inspect the parade. After the inspection, the party returns to the dais. The PCDR— <ul style="list-style-type: none"> – requests permission to hand over the QC; – salutes; and – returns to their position. | | |
| Handing over the QC | | | |
| 10 | PCDR | RECEIVING AND RETIRING COLOUR PARTIES TAKE – POST | <ul style="list-style-type: none"> – Both QCPs step off together. – The receiving QCP marches out to a position in front of the dais (a distance to be determined by the area of the parade ground) and halts facing the left flank of the parade ground. – The retiring QCP marches out and halts facing the receiving QCP at seven paces distance. – Movements of both QC parties are to be coordinated, using drum beats. – The QC orderly takes up position independently. |
| 11 | PCDR | UNCASE THE QUEEN'S COLOUR PARADE PRESENT – ARMS | |

UNCLASSIFIED

NZAP 2.4 Manual of Ceremonial and Drill

Version 6.00

Part 4 - Queen's Colour and Squadron Standard Ceremonial Drill

13 June 2023

Chapter 5 – King's Birthday Parade with Queen's Colour Handover

| Table 4-5-13 Alternative procedure for handing over the Queen's Colour (cont.) | | | |
|---|------------------|-------------------------------------|--|
| Serial | Commander | Command | Action |
| 12 | | | <p>The QC escorts of both QCPs—</p> <ul style="list-style-type: none"> – make a three quarter about turn alternatively left/right, so that they face outwards from the QC; – at the same time they are to bring their rifles to the 'On Guard' position. <p>The receiving QCB salutes with the sword.</p> <p>As soon as the last movement of the 'Present' is completed, the retiring QC W/O—</p> <ul style="list-style-type: none"> – moves via the right flank of the retiring QCP; and – assists in the uncasing of the QC. (The case is to be draped over the left arm.) <p>At the same time, the QCO moves into position to await the case.</p> <p>After the QC has been uncased and the QCB has brought the QC to the order, the QC W/O—</p> <ul style="list-style-type: none"> – salutes; – turns right; – moves to a position one pace from the QCO; – halts; – hands the case to the QCO; – turns right again; – moves to their original position; – halts; – draws their sword in unison with the receiving QC W/O. <p>The QCO, on receiving the case—</p> <ul style="list-style-type: none"> - salutes; - turns; and - marches off the parade ground. |
| 13 | PCDR | SHOULDER – ARMS | |
| 14 | PCDR | HAND OVER THE QUEEN'S COLOUR | |

UNCLASSIFIED

NZAP 2.4 Manual of Ceremonial and Drill

Version 6.00

Part 4 - Queen's Colour and Squadron Standard Ceremonial Drill

13 June 2023

Chapter 5 – King's Birthday Parade with Queen's Colour Handover

| Table 4-5-13 Alternative procedure for handing over the Queen's Colour (cont.) | | | |
|---|------------------|--|---|
| Serial | Commander | Command | Action |
| 15 | | | <ul style="list-style-type: none"> - The receiving QCB returns the sword and reports— <i>'Flight Lieutenant and Queen's Colour Party of RNZAF Base</i>' - The retiring and receiving QCBs each take three paces forward. - The QC is brought to the carry. - The receiving QCB— <ul style="list-style-type: none"> - moves forward; and - grasps the QC pike. - The retiring QCB then says— <i>'I give into your safe keeping the Queen's Colour of the Royal New Zealand Air Force. I charge you to guard and defend it.'</i> - The receiving QCB responds— <i>'I will do so.'</i> - The retiring QCB relinquishes their hold on the QC. - The receiving QCB— <ul style="list-style-type: none"> - resumes their original position by stepping back three paces; and - brings the QC to order. - At the same time the retiring QCB— <ul style="list-style-type: none"> - takes three paces to the rear; - draws their sword; and - salutes. |
| 16 | PCDR | MARCH ON THE QUEEN'S COLOUR PARADE PRESENT – ARMS | <ul style="list-style-type: none"> - The receiving QCB brings the QC to the carry on the 'SHOULDER ARMS' - The band plays POINT OF WAR. |
| 17 | | | At the conclusion of the music— |
| | Receiving QCB | COLOUR PARTY – LEFT WHEEL – QUICK – MARCH | <ul style="list-style-type: none"> - The QCP— <ul style="list-style-type: none"> - moves in quick time by a series of pivot wheels to a position six paces in front of No.2 Flight of the escort squadron; and - halts facing the dais. - The band plays the RNZAF March. - The retiring QCP— <ul style="list-style-type: none"> - presents arms with the parade; and - holds the present until the receiving QCP has passed their front. |
| 18 | Retiring QCB | RETIRING COLOUR PARTY SHOULDER – ARMS BY THE CENTRE QUICK MARCH | <ul style="list-style-type: none"> - The retiring QCP marches in step with the receiving QCP, moving straight ahead until clear of the parade ground where they are dismissed. |

UNCLASSIFIED

NZAP 2.4 Manual of Ceremonial and Drill

Version 6.00

Part 4 - Queen's Colour and Squadron Standard Ceremonial Drill

13 June 2023

Chapter 5 – King's Birthday Parade with Queen's Colour Handover

| Table 4-5-13 Alternative procedure for handing over the Queen's Colour (cont.) | | | |
|---|------------------|--|---|
| Serial | Commander | Command | Action |
| 19 | PCDR | PARADE THE QUEEN'S COLOUR COLOUR PARTY TAKE – POST | <ul style="list-style-type: none"> – The QCP, under the command of the QCB— – executes a fixed pivot wheel; and – marches along the front of the squadron to a position 10 paces to the left flank of the last flight. – On reaching their position, the QCP— – wheels left; – wheels left again when in line between front and centre rank; and – halts seven paces from the left flank of the last flight, with the QCB in line with the front rank. |
| 20 | QCB | COLOUR PARTY TAKE – POST | <ul style="list-style-type: none"> – QCP— – takes one pace to the rear; – turns right with the W/O; and – moves to the following positions— – QC W/O - to the rear of rear rank. – QCP – to the rear of front and centre ranks. – QCB - between the officer rank and front rank. – turns left; and – takes one pace forward to be opposite and in line with the QCB. |
| 21 | PCDR | PARADE PRESENT – ARMS | |
| 22 | QCB | COLOUR PARTY BY THE LEFT SLOW – MARCH | <ul style="list-style-type: none"> – The QCP slow marches through the line of flights. – The band plays a slow march – When the QCP has cleared the right flank of No.1 Flight, the band stops playing. |
| 23 | QCB | COLOUR PARTY – HALT COLOUR PARTY TAKE – POST | <ul style="list-style-type: none"> – The QCP reforms back onto the QCB by using the reverse procedure for getting there. |
| 24 | QCB | COLOUR PARTY LEFT WHEEL BY THE CENTRE QUICK – MARCH | <ul style="list-style-type: none"> – By a series of pivot wheels the QCP march straight back to their position in the front centre of the squadron facing the dais. |

UNCLASSIFIED

NZAP 2.4 Manual of Ceremonial and Drill

Version 6.00

Part 4 - Queen's Colour and Squadron Standard Ceremonial Drill

13 June 2023

Chapter 5 – King's Birthday Parade with Queen's Colour Handover

| Table 4-5-13 Alternative procedure for handing over the Queen's Colour (cont.) | | | |
|---|------------------|---|--|
| Serial | Commander | Command | Action |
| 25 | PCDR | PARADE SHOULDER – ARMS IN CLOSE ORDER – RIGHT DRESS EYES – FRONT PARADE WILL ADVANCE IN REVIEW ORDER BY THE CENTRE QUICK – MARCH (SEVEN PACES) GENERAL SALUTE PRESENT – ARMS SHOULDER – ARMS | <ul style="list-style-type: none"> – The reviewing officer and their party move from the dais to a position in front of the parade. |
| 26 | PCDR PCDR | ROYAL SALUTE PRESENT – ARMS | <ul style="list-style-type: none"> – The band plays the first verse of British Nation Anthem. – At the same time the Sovereign's personal flag for New Zealand is broken at the masthead. |
| 27 | PCDR | PARADE SHOULDER – ARMS PARADE WILL REMOVE HEADDRESS REMOVE – HEADDRESS | <ul style="list-style-type: none"> – The QCP does not act on this command. – Officers and other ranks are to remove their headdress with their left hand. – Band remove their headdress with their right hand. |
| 28 | PCDR | THREE CHEERS FOR HIS MAJESTY THE KING HIP-HIP-HURRAY HIP-HIP-HURRAY HIP-HIP-HURRAY | <ul style="list-style-type: none"> – Headdress is to be raised to the full extent of the arm with each cheer. |
| 29 | PCDR | PARADE WILL REPLACE HEADDRESS REPLACE – HEADDRESS ROYAL SALUTE PRESENT – ARMS | <ul style="list-style-type: none"> – The band plays the first verse of British Nation Anthem. – The Sovereign's personal flag for New Zealand is lowered in time with the music. |
| 30 | PCDR | SHOULDER – ARMS | |
| 31 | | | <ul style="list-style-type: none"> – The reviewing officer and their party move back to the dais. – The PCDR reports to the reviewing officer and states— <i>'That completes this part of the ceremony, Sir/Ma'am.'</i> <i>'Do you wish to address the parade?'</i> – If in the affirmative, the PCDR— <ul style="list-style-type: none"> – stands the parade at ease; and – moves to a position beside the dais. – After the address, the PCDR— <ul style="list-style-type: none"> – brings the parade to attention; and – requests permission to carry on. |

UNCLASSIFIED

NZAP 2.4 Manual of Ceremonial and Drill

Version 6.00

Part 4 - Queen's Colour and Squadron Standard Ceremonial Drill

13 June 2023

Chapter 5 – King's Birthday Parade with Queen's Colour Handover

| Table 4-5-13 Alternative procedure for handing over the Queen's Colour (cont.) | | | |
|---|------------------|---|--|
| Serial | Commander | Command | Action |
| 32 | PCDR | OFFICERS TAKE POST – LEFT – TURN QUICK – MARCH INWARDS – TURN PARADE MOVE TO THE RIGHT IN COLUMN OF ROUTE RIGHT – TURN BY THE LEFT – QUICK – MARCH | <ul style="list-style-type: none"> – The squadron marches from the venue, led by the band. – Lodging arrangements as dictated by the weather will then follow. |

Chapter 6 – Squadron Standards

4.6.1 General

- a. Except as specified in this chapter, the procedure for Squadron Standards (SqnSs) should conform to that for the Queen's Colour (QC), whenever paraded for ceremonial purposes.
- b. SqnSs are awarded to operational squadrons that have been in existence for twenty five years. SqnSs may also be awarded to squadrons that have been in existence for a shorter period, but that have earned the Sovereign's appreciation for outstanding operational service.
- c. SqnSs are to be carried, attended and escorted, only by officers, a warrant officer (W/O) and other ranks (ORs). The SqnSB should hold the rank of Pilot Officer (PLTOFF) or Flying Officer (FGOFF) and be of an Aircrew trade.

4.6.2 Occasions on which Squadron Standards may be paraded

SqnSs may be paraded—

- (1) on ceremonial parades;
- (2) with guards of honour;
- (3) with route lining detachments; and
- (4) at Service funerals.

4.6.3 Position of Squadron Standards on parade

- a. When the QC is paraded with a SqnS on a wing parade, No.1 Squadron is to escort the QC and the squadron with the SqnS is to be No.2 Squadron on the parade. The SqnS is to be marched on first and, when in position, the QC is to be marched on from the left flank across the front of the parade. The SqnS is to be lowered in salute.

Note: This procedure does not apply when a Royal Guard of Honour is mounted.

- b. When the QC is paraded by a squadron to which a SqnS has been awarded, the QC party is to be as shown in Figure [4-6-1](#) as follows—
 - (1) Two junior officers.
 - (2) Three senior non-commissioned officers (SNCOs).
 - (3) Two W/Os.

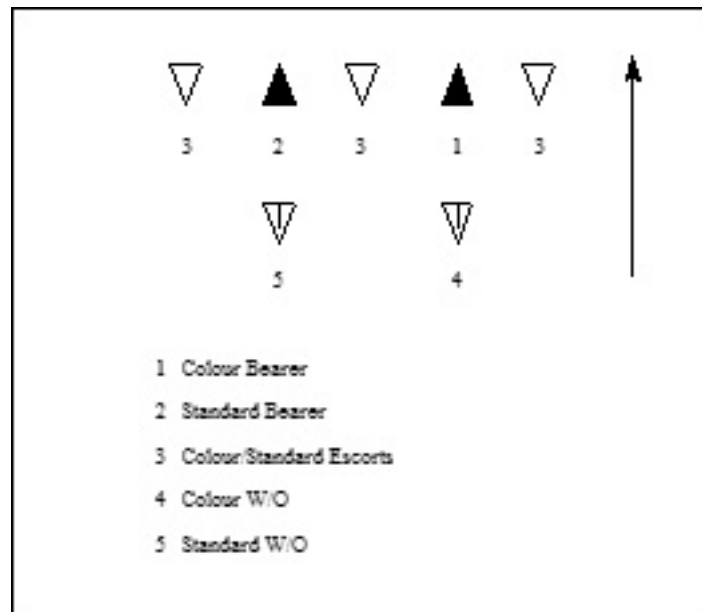

Figure 4-6-1 Composition of Combined Queen's Colour/Squadron Standard Party

c. Marching on

- (1) The QC party, commanded by the QC bearer, marches to the rear of the royal guard and wheels into position in the centre.
- (2) Forming column of route from line. Under the orders of the QC bearer the QC party turns about and takes up position by wheeling left/right and halting on the tenth pace without further word of command.
- (3) Forming line from column of route. The QC party takes position on the command of the QC bearer.

Note: At all times the QC is to be on the right.

4.6.4 Compliments to be paid

- a. Individuals are always to salute an uncased SqnS when passing or being passed by it.
- b. An individual carrying a rifle is to give a butt salute when passing an uncased SqnS. They to halt and present arms if the SqnS passes them.
- c. Where an uncased passes an unarmed party on the march, the unarmed party is to halt, turn into line and salute, and the SqnS, if at the shoulder, is to be brought to the carry. If the SqnSP is armed it is to halt, turn into line and present arms.
- d. When a party on the march passes an armed party at the halt with an uncased SqnS at the order, the party at the halt is to be brought to attention, the SqnS to the carry. The marching party is to give eyes right/left.
- e. Parties with a cased SqnS are always to pay compliments to an uncased SqnS.

UNCLASSIFIED

NZAP 2.4 Manual of Ceremonial and Drill
Part 4 - Queen's Colour and Squadron Standard Ceremonial Drill
Chapter 6 – Squadron Standards

Version 6.00
13 June 2023

- f. When two parties pass, each carrying a cased or uncased SqnS, no compliments are to be exchanged.

4.6.5 The salute by lowering the Squadron Standard

The SqnS is lowered in salute to the following—

- (1) Members of the Royal Family;
- (2) The Governor General;
- (3) Marshals of the Royal Air Force;
- (4) Admirals of the Fleet;
- (5) Field Marshals;
- (6) Chief of Defence Force (CDF); and
- (7) New Zealand Defence Force (NZDF) single Service Chiefs.

4.6.6 The Royal Standard and other personal standards

Instructions for flying the sovereign's personal flags are contained in [AFGO](#) *Air Force General Orders*.

4.6.7 Roles of SqnSPs

- a. Royal New Zealand Air Force (RNZAF) SqnSPs are configured as a complete unit of five personnel. Each component of the party is integral to the unit as a whole.
- b. There are no occasions when the SqnS is to be separated from its various components.
- c. The W/O's role is to support the SqnSB at any time the SqnS is to be attended to and/or dressed as appropriate.
- d. The role of the RNZAF SqnSPs is to protect the SqnS at all times. To achieve this there will be significant times when members of the SqnSP will not salute as to do so would render the SqnS vulnerable. Royal/general salutes are the only exceptions to this rule.

Note: Under no circumstances is the SqnS is to be used for rehearsals. A practice standard is to be maintained for this purpose.

Chapter 7 – Presentation of a Squadron Standard

4.7.1 Introduction

The parade is to consist of an armed Squadron Standard (Sqns) escort squadron (two flights), a Squadron Standard party (SqnsP), two support squadrons and the Royal New Zealand Air Force (RNZAF) Band. The format is as follows—

- (1) Assembly and march on of support squadrons, followed by the escort squadron with SqnsP and the RNZAF Band.
- (2) Reception of the reviewing officer.
- (3) Inspection of the parade.
- (4) Dedication of the Sqns.
- (5) Presentation of the Sqns.
- (6) Address by the Reviewing Officer.
- (7) Reply by Parade Commander (PCDR).
- (8) Parading the Sqns.
- (9) Three cheers for His Majesty the King.
- (10) Lodging the Sqns.

4.7.2 Assembly and march on of support squadrons and padres/chaplains

- a. Each support squadron forms up in line on the parade ground at attention before the march on of the escort squadron.
- b. Before the parade, the padres/chaplains take up a position to the right of the dais facing the parade with the Principal Chaplain nearest to the dais.

4.7.3 Assembly of the Squadron Standard escort squadron and Squadron Standard party

The procedure for the assembly and falling in of the escort squadron and the SqnsP is shown in Table [4-7-1](#).

UNCLASSIFIED

NZAP 2.4 Manual of Ceremonial and Drill
 Part 4 - Queen's Colour and Squadron Standard Ceremonial Drill
 Chapter 7 – Presentation of a Squadron Standard

Version 6.00
 13 June 2023

Table 4-7-1 Assmeby and Fall in of Escort Squadron and Squadron Standard Party

| Serial | Commander | Command | Action |
|--------|--|--|---|
| 1 | | | <ul style="list-style-type: none"> – The escort squadron falls in on the predetermined assembly area with the SqnSP and the band. The squadron falls in as normal. – The SqnS W/O brings the cased SqnS on parade, at the shoulder. – The SqnSP on the right of the supernumerary ranks of No.2 Flight (SqnS W/O to the left) covering two, three and four files. – The SqnSB parades as a supernumerary officer covering the right file of No.2 Flight. – The band falls in 10 paces to the right flank of No.1 Flight of the escort squadron. – The SWO falls in the escort squadron and SqnSP, then hands over the parade to the PADJ. |
| 2 | PADJ | OFFICERS WILL DRAW SWORDS DRAW – SWORDS FALL IN THE OFFICERS | <ul style="list-style-type: none"> – The officers carry out the normal fall in procedure. – When the officers are in position, the APDJ hands the parade over to the PCDR. |
| 3 | PCDR | STANDARD ESCORT SQUADRON MOVE TO THE RIGHT IN COLUMN OF THREES RIGHT – TURN BY THE LEFT QUICK – MARCH | <ul style="list-style-type: none"> – The escort squadron, led by the band marches on in column of threes. – As the squadron approaches the position it is to occupy on the parade ground, the band wheels right and counter marches into its position centrally behind the escort squadron. |
| 4 | As the squadron reaches the position it is to occupy on the parade ground— | | |
| | PCDR | ESCORT SQUADRON HALT SQUADRON WILL ADVANCE LEFT TURN | |
| 5 | PCDR | PARADE OFFICERS TAKE POST IN REVIEW ORDER OUTWARDS TURN QUICK MARCH | <ul style="list-style-type: none"> – The escort squadron supernumerary NCO and F/S)— – turn left and right respectively; and – march to their new positions in the front rank and stand next to the left and right hand guides of No.1 and No.2 flights. |
| 6 | When the officers are in position— | | |
| | PCDR | INWARDS TURN ESCORT SQUADRON FORM TWO RANKS ESCORT SQUADRON OPEN ORDER MARCH PARADE RIGHT DRESS | <ul style="list-style-type: none"> – The Escort squadron inwards dress without intervals. |
| 7 | PCDR | EYES – FRONT | |

UNCLASSIFIED

| Table 4-7-1 Assmebly and Fall in of Escort Squadron and Squadron Standard Party (cont.) | | | |
|--|------------------|--|---|
| Serial | Commander | Command | Action |
| 8 | PCDR | MARCH ON THE CASED STANDARD | <ul style="list-style-type: none"> - The SqnS W/O— - shoulders the cased SqnS; - turns about; - marches between Nos.1 and 2 Flights; - lays the SqnS against the piled drums, with the pike to the left; - returns to their position by the same route; - draws their sword, on arrival at their position. |
| 9 | PCDR | STANDARD PARTY TAKE POST RIGHT – TURN | <ul style="list-style-type: none"> - The SqnSP turns right |
| 10 | PCDR | STANDARD PARTY QUICK MARCH | <ul style="list-style-type: none"> - The SqnSB leads off wheeling into position between Nos.1 and 2 Flights and two paces centrally in front of the squadron. - At the same time, the SqnS escort— <ul style="list-style-type: none"> - opens out to three paces interval; - halts in line with the front rank of the squadron; and - without further command, orders arms. - The SqnS W/O takes up position centrally and in line with the rear rank of the squadron. - The SqnSP halt together. |
| 11 | PCDR | PARADE STAND AT – EASE | |

UNCLASSIFIED

UNCLASSIFIED

NZAP 2.4 Manual of Ceremonial and Drill
 Part 4 - Queen's Colour and Squadron Standard Ceremonial Drill
 Chapter 7 – Presentation of a Squadron Standard

Version 6.00
 13 June 2023

4.7.4 Reception of the reviewing officer

The procedure for the reception of the reviewing officer is shown in Table [4-7-2](#).

Table 4-7-2 Procedure for Receiving the Reviewing Officer

| Serial | Commander | Command | Action |
|--------|--|---|---|
| 1 | As the reviewing officer approaches— | | |
| | PCDR | PARADE PARADE – SHUN | |
| 2 | When the reviewing officer is in position on the dais— | | |
| | PCDR | PARADE GENERAL SALUTE PRESENT – ARMS SHOULDER – ARMS | <ul style="list-style-type: none"> – The PCDR— – approaches the dais; – salutes; and – invites the reviewing officer to inspect the parade. – After the inspection, they return to the saluting base where the PCDR— – requests permission to carry on with the parade; – salutes; and – moves to a position to the left of the piled drums facing the SqnSP escort squadron. |

4.7.5 Dedication of the Squadron Standard

The procedure for the dedication of a SqnS is shown in Table [4-7-3](#).

Table 4-7-3 Procedure for the Dedication of a Squadron Standard

| Serial | Commander | Command | Action |
|--------|---|---|--|
| 1 | PCDR | PARADE STAND AT – EASE | <ul style="list-style-type: none"> – Two officers, so detailed, and the QCO— – march forward; and – uncase the SqnSP. – The case is handed to the QCO, who marches off the parade. – The silk is draped over the drums facing the parade, pike to the left. – The two officers return to their original positions. |
| 2 | After the SqnS has been uncased— | | |
| | <ul style="list-style-type: none"> – the reviewing officer and the BCDR move into position to the right and rear of the piled drums facing the parade and, – the padres/chaplains move to a position in front of and facing the piled drums with the Principal Chaplain on the right. | | |

| Table 4-7-3 Procedure for the Dedication of a Squadron Standard (cont.) | | | |
|---|--|---------------------------------------|---|
| Serial | Commander | Command | Action |
| 3 | When the padres/chaplains are in position— | | |
| | PCDR | PARADE PARADE – SHUN | <ul style="list-style-type: none"> – The PCDR— – turns left; – faces the Principal Chaplain; and – salutes. |
| 4 | <p>– PCDR says to the Principal Chaplain— <i>‘Reverend Sir/Ma’am, on behalf of No ... Squadron we ask you to bid God’s blessing on this Standard.’</i></p> <p>– The Principal Chaplain replies— <i>‘We are ready to do so.’</i></p> <p><i>‘We are gathered here to dedicate this Standard, the solemn symbol of our loyalty and with it ourselves, our Service and our life. May this Standard never be unfurled save in the cause of justice, righteousness and truth.’</i></p> <p>– The Principal Chaplain and the PCDR (on behalf of the parade) then say—</p> <p>Principal Chaplain— <i>‘We are required to dedicate ourselves—</i> <i>to the service of God in the honour of Their Holy name;</i> <i>to the love of our Sovereign and Country;</i> <i>to the welfare of humankind;</i> <i>to the protection of all those who go about their legitimate purposes; and</i> <i>to the preservation of order and good government.’</i></p> <p>PCDR— <i>‘To those ends we dedicate ourselves.’</i></p> <p>Principal Chaplain— <i>‘We are also required to dedicate this Standard to the memory of our comrades, whose courage and endurance add undying lustre to the emblems.</i> <i>In continual remembrance of our solemn oath and in token of our resolve, do you pledge to guard and honour this Standard faithfully.’</i></p> <p>PCDR— <i>‘We so dedicate ourselves to our Standard.’</i></p> <p>Three padres/chaplains say in unison— <i>‘Our help is in the name of the Lord who made heaven and earth.</i> <i>To the glory of God and as a symbol of our duty to Him and of our service to our Sovereign, we dedicate this Standard in the name (extending their hands over the Standard) of the Father and of the Son and of the Holy Spirit.’</i></p> <p>Note: The term Him is not to be taken out of context as a gender reference as the wording of this prayer follows Scriptural language.</p> <p>All— <i>‘Amen.’</i></p> <p>Note: A microphone (if required) will be prepositioned for the PCDR and padres/chaplains.</p> | | |

UNCLASSIFIED

NZAP 2.4 Manual of Ceremonial and Drill
 Part 4 - Queen's Colour and Squadron Standard Ceremonial Drill
 Chapter 7 – Presentation of a Squadron Standard

Version 6.00
 13 June 2023

| Table 4-7-3 Procedure for the Dedication of a Squadron Standard (cont.) | | | |
|--|---|-----------------------------------|---------------|
| Serial | Commander | Command | Action |
| 5 | PCDR | PARADE STAND AT – EASE | |
| 6 | Chaplain— <i>‘Lord God Almighty, before whom the nations of the earth rise and fall, watch over our nation. Guide, strengthen and teach us so that we may make this land a place where people walk in the freedom of Your truth, and live in the light of Your knowledge. Grant that all who serve beneath our Standard not forget the cost of those who went before us. May we work for peace, dignity and hope for all people according to the example of Him who died upon a cross in the service of mankind.’</i> All— <i>‘Amen.’</i> Chaplain— <i>‘Merciful Father, in Your great goodness be present to all who shall follow this Standard now committed to our care. May our courage rest in our confidence in You. May we show self-control in the hour of success, patience in the time of adversity. May we know Your guidance in time of doubt, Your protection in danger and Your comfort in sorrow. May our honour lie in seeking the honour and glory of Your great Name through Jesus Christ our Lord.’</i> All— <i>‘Amen.’</i> Principal Chaplain— <i>‘Remember always, that this Standard, which we have here dedicated to God, represents to us, our duty to our King and country — which is to serve him, his realm and our fellow citizens to the utmost of our power; to maintain as much as we are able the gift of honour; to protect all those who go about their legitimate purposes; to preserve order and good government, after the example of our comrades who were prepared to sacrifice themselves, so that others might live in peace.’</i> All— <i>‘Amen.’</i> | | |
| 7 | – The padres/chaplains return to their original position on the right of the saluting base. | | |

UNCLASSIFIED

4.7.6 Presentation of the Squadron Standard

The procedure for the presentation of a SqnS is shown in Table [4-7-4](#).

Table 4-7-4 Procedure for the Presentation of a Squadron Standard

| Serial | Commander | Command | Action |
|--------|-----------|--|---|
| 1 | PCDR | PARADE PARADE – SHUN | <ul style="list-style-type: none"> - The SqnSB— - marches straight forward to a position three paces from the piled drums; - replaces their sword; and - sinks forward onto the right knee. - The BCDR— - takes the SqnS from the piled drums; and - hands it to the reviewing officer. - The SqnSB— - receives the SqnS from the reviewing officer; - rises; and - takes one step back. |
| 2 | | | <ul style="list-style-type: none"> - The reviewing officer gives their address. <p>Note: The microphone is to be repositioned alongside the reviewing officer.</p> <ul style="list-style-type: none"> - The PCDR makes the reply. |
| 3 | | | <ul style="list-style-type: none"> - The PCDR marches to a position in front of the left flank of No.1 Flight. - At the same time— - the reviewing officer and BCDR return to the dais; and - the microphone is removed from the parade ground. - The SqnSB turns about. |
| 4 | PCDR | MARCH ON THE SQUADRON STANDARD PRESENT – ARMS | <ul style="list-style-type: none"> - The band plays the New Zealand Nation Anthem. - The SqnSB— - marches 42 paces in slow time to a position in the centre of the parade two paces in front of the escort squadron; - turns about; and - halts (on the last note of the New Zealand National Anthem). |
| 5 | PCDR | ESCORT SQUADRON SHOULDER – ARMS | <ul style="list-style-type: none"> - The PCDR returns to their original position in front of the escort squadron. |

UNCLASSIFIED

| Table 4-7-4 Procedure for the Presentation of a Squadron Standard (cont.) | | | |
|--|------------------|--|---|
| Serial | Commander | Command | Action |
| 6 | PCDR | ESCORT SQUADRON – CLOSE – ORDER – MARCH PARADE OFFICERS TAKE POST – LEFT – TURN QUICK – MARCH INWARDS – TURN | <ul style="list-style-type: none"> – The F/Ss and supernumerary NCOs move back to their original positions. – The knee stool is removed from the parade area by an orderly. |
| 7 | PCDR | ESCORT SQUADRON FORM THREE – RANKS | |
| 8 | SqnSB | ESCORT SQUADRON FORM THREE – RANKS | <ul style="list-style-type: none"> – The escort squadron dress inwards. |
| 9 | SqnSB | EYES FRONT | |

4.7.7 Parading the Squadron Standard

The procedure for parading the SqnS is shown in Table [4-7-5](#).

Table 4-7-5 Procedure for parading a Squadron Standard

| Serial | Commander | Command | Action |
|---|------------------|--|--|
| 1 | PCDR | ESCORT SQUADRON MOVE TO THE RIGHT IN THREES RIGHT – TURN | <ul style="list-style-type: none"> – The SqnSP acts on the command of the PCDR. |
| Note: At all times when on the march the SqnS escorts are to be on either side of the SqnSB. | | | |
| 2 | PCDR | ESCORT SQUADRON BY THE LEFT QUICK... | <ul style="list-style-type: none"> – The Band plays drums only. – On the third beat of the second drum sequence— <ul style="list-style-type: none"> – No.1 Flight wheels at Point 1; – the SqnSP wheels 14 paces further on; – No.2 Flight wheels at a further 14 paces. |
| 3 | | – As the squadron approaches the dais— | |
| | PCDR | AT THE HALT FACING LEFT, FORM CLOSE COLUMN OF FLIGHTS | <ul style="list-style-type: none"> – FLTCDRs— <ul style="list-style-type: none"> – halt their flights independently; and – left turn into line. – The SqnSP— <ul style="list-style-type: none"> – left wheels into position; – halts; then – turns left by a fixed pivot wheel. |
| 4 | PCDR | ESCORT SQUADRON RIGHT – DRESS EYES – FRONT | |

UNCLASSIFIED

UNCLASSIFIED

NZAP 2.4 Manual of Ceremonial and Drill
 Part 4 - Queen's Colour and Squadron Standard Ceremonial Drill
 Chapter 7 – Presentation of a Squadron Standard

Version 6.00
 13 June 2023

| Table 4-7-5 Procedure for parading a Squadron Standard (cont.) | | | |
|---|--|--|--|
| Serial | Commander | Command | Action |
| 5 | PCDR | ESCORT SQUADRON WILL MARCH PAST BY FLIGHTS IN CLOSE COLUMN IN SLOW TIME AT 14 PACES DISTANCE BY THE RIGHT SLOW... | <ul style="list-style-type: none"> - On the third beat of the second drum sequence the parade steps off - The band plays marching music. |
| 6 | - As No. 1 flight reaches a predetermined point— | | |
| | FLTCDR | NO.... FLIGHT EYES – RIGHT | |
| 7a | - As the rear rank of the flight passes another predetermined point— | | |
| | FLTCDR | NO.... FLIGHT EYES – FRONT | |
| 7b | - The SqnSP acts on the orders of the SqnSB. | | |
| 7c | - FLTCDRs of subsequent flights command their flights as for No 1 Flight (serials 6 and 7a). | | |
| 8 | - The parade marches back to their original positions. | | |
| 9 | PCDR | ESCORT SQUADRON HALT ABOUT – TURN | <ul style="list-style-type: none"> - Supernumerary officers and NCOs— <ul style="list-style-type: none"> - turn about; - turn left; and - take up position at the rear of their flights. - FLTCDRs— <ul style="list-style-type: none"> - turn about; - turn right; and - take up position in front of their flights. |
| 10 | PCDR | ESCORT SQUADRON RIGHT – DRESS EYES – FRONT | <ul style="list-style-type: none"> - Compliments are paid by PCDR and SqnSB. - Supernumerary officers do not salute. - The band plays music. |
| 11 | PCDR | ESCORT SQUADRON – WILL MARCH PAST IN CLOSE COLUMN OF FLIGHTS IN QUICK TIME BY THE LEFT QUICK – MARCH | |
| 12 | - As the escort squadron reaches a predetermined point— | | |
| | PCDR | SQUADRON EYES – LEFT | |
| 13 | - As the rear rank of No.1 Flight passes, the Squadron commander(PCDR)— | | |
| | PCDR | SQUADRON EYES – FRONT | |

UNCLASSIFIED

NZAP 2.4 Manual of Ceremonial and Drill
 Part 4 - Queen's Colour and Squadron Standard Ceremonial Drill
 Chapter 7 – Presentation of a Squadron Standard

Version 6.00
 13 June 2023

| Table 4-7-5 Procedure for parading a Squadron Standard (cont.) | | | |
|---|--|---|---|
| Serial | Commander | Command | Action |
| 14 | As the rear rank of No.1 Flight comes in line with the SqnS— | | |
| | PCDR | ESCORT SQUADRON HALT ABOUT – TURN | – Supernumerary officers and NCOs carry out the same drill. |
| 15 | PCDR | MOVE TO THE LEFT IN COLUMN OF THREES LEFT – TURN | |
| 16a | No. 2 FLTCDR | NO.... 2 FLIGHT BY THE RIGHT QUICK – MARCH | |
| 16b | – The SqnSP acts on the orders of the SqnSB. | | |
| 16c | – FLTCDRs of subsequent flights command their flights as for No 2 Flight (serials 12–16a). | | |
| 17 | PCDR | ESCORT SQUADRON HALT ESCORT SQUADRON WILL ADVANCE RIGHT – TURN | |

4.7.8 Advance in review order

The procedure for the advance in review order is shown in Table [4-7-6](#).

Table 4-7-6 Procedure for Advance in Review Order

| Serial | Commander | Command | Action |
|---------------|------------------|--|---|
| 1 | PCDR | PARADE OFFICERS TAKE POST IN REVIEW ORDER OUTWARDS – TURN QUICK – MARCH OFFICERS – LEFT – TURN PARADE RIGHT – DRESS EYES – FRONT ESCORT SQUADRON WILL ADVANCE IN REVIEW ORDER BY THE CENTRE QUICK MARCH | – The band plays a tune that signifies the 'Advance in Review Order'. |
| 2 | PCDR | SQUADRON ROYAL SALUTE PRESENT – ARMS | – The band plays a tune that signifies the 'Royal Salute' |

UNCLASSIFIED

UNCLASSIFIED

NZAP 2.4 Manual of Ceremonial and Drill
 Part 4 - Queen's Colour and Squadron Standard Ceremonial Drill
 Chapter 7 – Presentation of a Squadron Standard

Version 6.00
 13 June 2023

4.7.9 Three Cheers for the Sovereign

The procedure for honouring the Sovereign is shown in Table [4-7-7](#).

Table 4-7-7 Procedure for Honouring the Sovereign

| Serial | Commander | Command | Action |
|--------|--|--|---|
| 1 | PCDR | ESCORT SQUADRON SHOULDER – ARMS PARADE WILL REMOVE HEADDRESS REMOVE – HEADDRESS | Note: The SqnSP do not act on this command. |
| 2 | PCDR | THREE CHEERS FOR HIS MAJESTY THE KING HIP-HIP-HURRAY HIP-HIP-HURRAY HIP-HIP-HURRAY | |
| 3 | PCDR | PARADE WILL REPLACE HEADDRESS REPLACE – HEADDRESS | |
| 4 | After the parade has replaced headdresses— | | |
| | PCDR | ROYAL SALUTE – PRESENT ARMS | <ul style="list-style-type: none"> – The band plays the first six bars of British Nation Anthem. – The Sovereign's personal flag for New Zealand is lowered in time with the music. |

4.7.10 Departure of the reviewing officer

On completion of the Royal Salute the reviewing officer leaves the dais, escorted by the Chief of Air Force (CAF)/the BCDR (as appropriate).

4.7.11 March off

The procedure for marching off and dispersal is shown in Table [4-7-8](#).

Table 4-7-8 Procedure for March off and Dispersal of a Squadron Standard Presentation Parade

| Serial | Commander | Command | Action |
|--------|--|---|--|
| 1 | – When the official party is clear of the parade ground— | | |
| | PCDR | PARADE – OFFICERS WILL TAKE POST LEFT – TURN QUICK – MARCH INWARDS – TURN ESCORT SQUADRON – MOVE TO THE RIGHT IN COLUMN OF ROUTE RIGHT – TURN | <ul style="list-style-type: none"> – The support squadrons stand fast. – The band plays off the escort squadron. |

UNCLASSIFIED

UNCLASSIFIED

| Serial | Commander | Command | Action |
|--------|------------------------------------|--|---|
| 2 | PCDR | ESCORT SQUADRON BY THE LEFT QUICK – MARCH (MUSIC) | |
| 3 | – The SqnS marches off the parade— | | |
| 4 | PCDR | ESCORT SQUADRON WILL ADVANCE LEFT – TURN RIGHT – DRESS EYES – FRONT | – No.1 Flight reforms into two sections with a gap to accommodate the SqnS. |
| 5 | PCDR | STANDARD PARTY – TAKE POST | – The SqnSP pivot wheels to halt in the gap, facing the front. |
| 6 | SqnSB | STANDARD PARTY BY THE CENTRE QUICK – MARCH | – The SqnSP marches off and is dismissed. |

4.7.12 Lodging a Squadron Standard

The procedure for lodging the SqnS is shown in Table [4-7-9](#).

4.7.13 Lodging of the Squadron Standard in the squadron hangar by the escort flight

The procedure for lodging the SqnS in the squadron hangar by the escort flight is shown in Table [4-7-10](#).

Table 4-7-9 Procedure for Quitting the Parade Ground before Lodging a Squadron Standard

| Serial | Commander | Command | Action |
|--------|-------------|---|--------|
| 1 | PCDR | STANDARD ESCORT SQUADRON NO.1 FLIGHT COMMANDER LODGE THE STANDARD SQUADRON PRESENT – ARMS | |
| 2 | No.1 FLTCDR | NO.1 FLIGHT MOVE TO THE RIGHT IN COLUMN OF ROUTE RIGHT – TURN ESCORT FLIGHT AND BAND BY THE LEFT QUICK – MARCH | |
| 3 | PCDR | SQUADRON SHOULDER – ARMS STAND AT – EASE FALL OUT THE OFFICERS WARRANT OFFICER (DISMISS FLIGHT) | |

UNCLASSIFIED

UNCLASSIFIED

NZAP 2.4 Manual of Ceremonial and Drill
 Part 4 - Queen's Colour and Squadron Standard Ceremonial Drill
 Chapter 7 – Presentation of a Squadron Standard

Version 6.00
 13 June 2023

Table 4-7-10 Procedure for Lodging a Squadron Standard in a Squadron Hangar

| Serial | Commander | Command | Action |
|--------|---------------|--|---|
| 1 | | | – On arrival at the No Squadron hangar, No.1 Flight marches into position centrally opposite the main door of the hangar. |
| 2 | Escort FLTCDR | ESCORT FLIGHT HALT ESCORT FLIGHT WILL ADVANCE LEFT –TURN | – The band acts on this command of the FLTCDR. |
| 3 | Escort FLTCDR | ESCORT FLIGHT INWARDS – DRESS | – The escort flight dresses on the Sqns centrally between two divisions of the flight. |
| 4 | Escort FLTCDR | EYES – FRONT ESCORT FLIGHT MARCH OFF THE SQUADRON STANDARD PRESENT – ARMS | – On command of the bandmaster the band plays 'Point of War'. |
| 5 | | | – At the conclusion of the music— |
| | SqnSB | STANDARD PARTY BY THE CENTRE QUICK – MARCH | – The band plays the 'RNZAF March'. – The SqnSP marches forward into the hangar. |
| 6 | | | – When the SqnSP has moved into the hangar (or other location) and positioned the Sqns in the bracket— |
| | Escort FLTCDR | ESCORT FLIGHT SHOULDER – ARMS MOVE TO THE RIGHT IN COLUMN OF ROUTE RIGHT – TURN | – On this command the band takes up position at the head of the column. |
| 7 | Escort FLTCDR | ESCORT FLIGHT BY THE RIGHT/ LEFT QUICK – MARCH | – The escort flight— – adjusts to normal dressing on the march; and – proceeds to the assembly area where they are dismissed. |

Posting escorts

- a. On entering the hangar the SqnSB—
- (1) halts the SqnSP five paces from the bracket;
 - (2) moves forward;
 - (3) positions the Sqns in the bracket;
 - (4) steps back five paces; and
 - (5) draws their sword.

UNCLASSIFIED

NZAP 2.4 Manual of Ceremonial and Drill
 Part 4 - Queen's Colour and Squadron Standard Ceremonial Drill
 Chapter 7 – Presentation of a Squadron Standard

Version 6.00
 13 June 2023

- b. The SqnSB gives the command—

ESCORTS TAKE POST

- the escorts take three paces forward, halt and inwards about turn.

c. When the escorts are positioned, the SqnSB and SqnS W/O salute.

d. The SqnSB turns about, steps off moving to the right/left of the SqnS W/O.

e. The SqnS W/O wheels around behind the SqnSB and leaves the building.

f. When the SqnSB and the SqnS W/O clear the area, SqnS escorts automatically stand at ease.

4.7.14 Sentry change

- a. On prolonged tours of duty it may be necessary to relieve the SqnS escorts.
- b. The SqnS W/O effects any necessary sentry changes.
- c. The SqnS W/O and the relieving escorts march through the main entrance to the foyer in the same formation as for the SqnSP and halt five paces from the SqnS.
- d. On their approach, the retiring escorts automatically come to attention.
- e. The SqnS W/O salutes the SqnS then gives the command—
RETIRING ESCORTS – QUICK MARCH
 – The retiring escorts march off.
- f. The SqnS W/O turns about and steps off when the retiring escorts have passed.
- g. The relieving escorts stand at ease as the party quits the area.

4.7.15 Dislodging the Squadron Standard

- a. When the time comes for the SqnS to be dislodged, the SqnSB and the SqnS W/O enter the foyer and halt five paces from the SqnS.
- b. As they halt, the SqnS escorts automatically come to attention.
- c. The SqnSB and SqnS W/O salute the SqnS.
- d. The SqnSB replaces their sword, moves forward, removes the SqnS from the bracket, dresses it at the order and then turns about.
- e. The SqnS W/O draws their sword and takes post behind the SqnSB.
- f. When in position the SqnSB gives the command—

STANDARD PARTY**BY THE CENTRE****QUICK – MARCH**

UNCLASSIFIED

NZAP 2.4 Manual of Ceremonial and Drill
Part 4 - Queen's Colour and Squadron Standard Ceremonial Drill
Chapter 7 – Presentation of a Squadron Standard

Version 6.00
13 June 2023

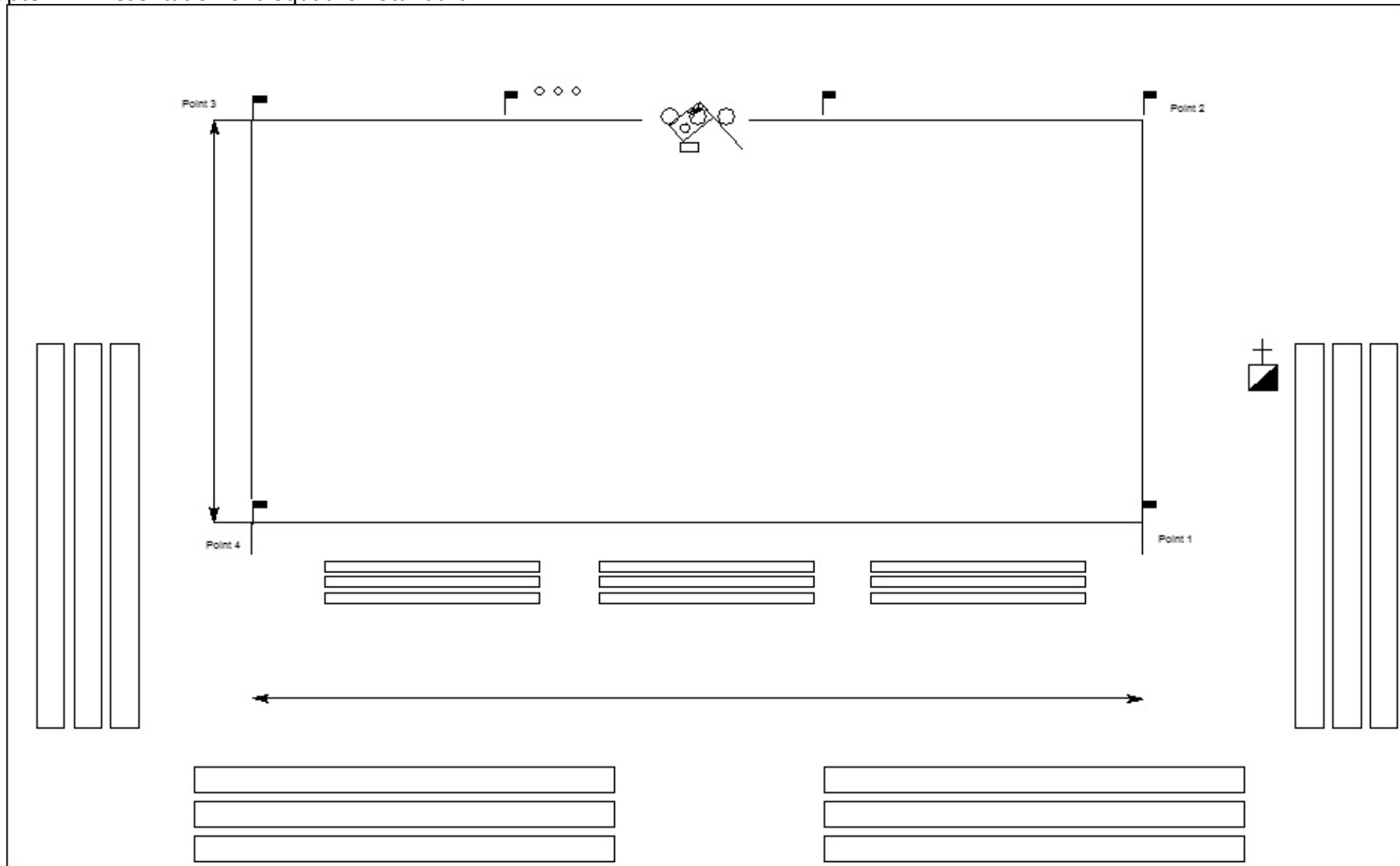

Figure 4-7-1 Parade Positions and Markers A

UNCLASSIFIED

UNCLASSIFIED

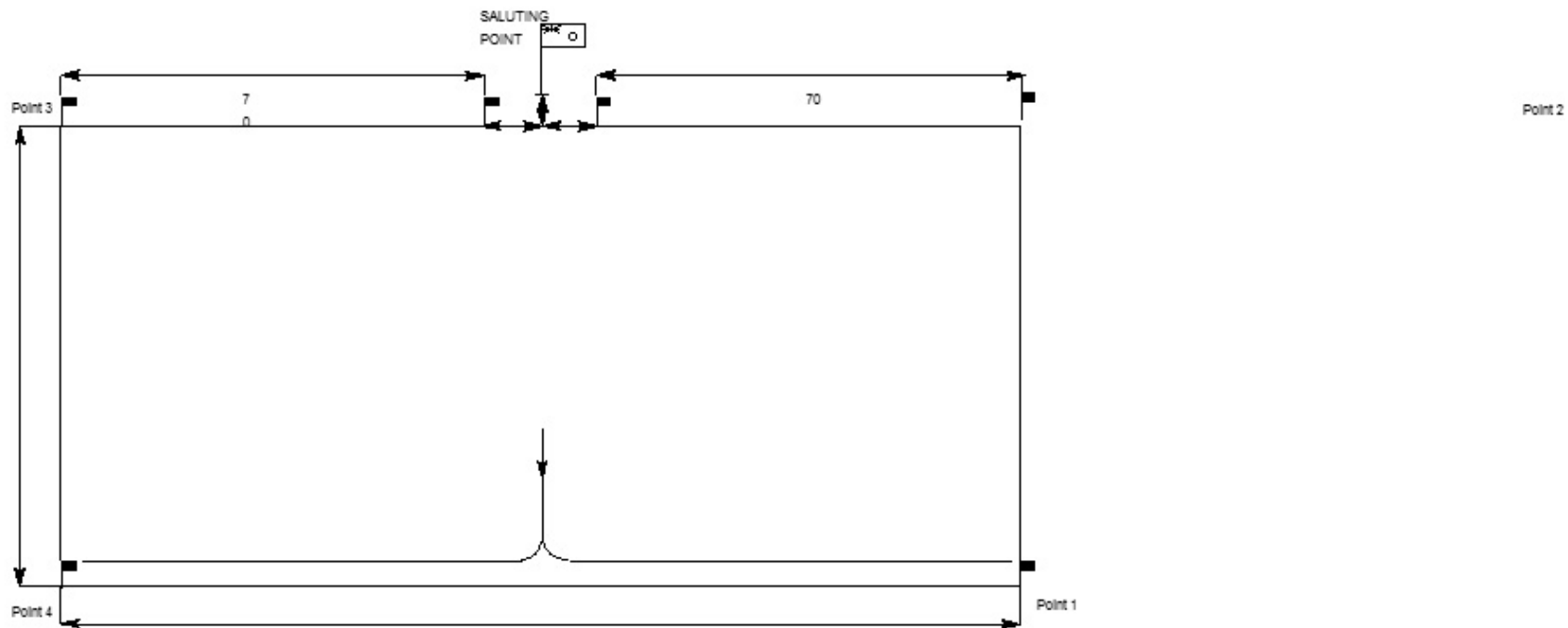

Figure 4-7-2 Parade Positions and Markers B

UNCLASSIFIED

UNCLASSIFIED

NZAP 2.4 Manual of Ceremonial and Drill
Part 4 - Queen's Colour and Squadron Standard Ceremonial Drill
Chapter 7 – Presentation of a Squadron Standard

Version 6.00
13 June 2023

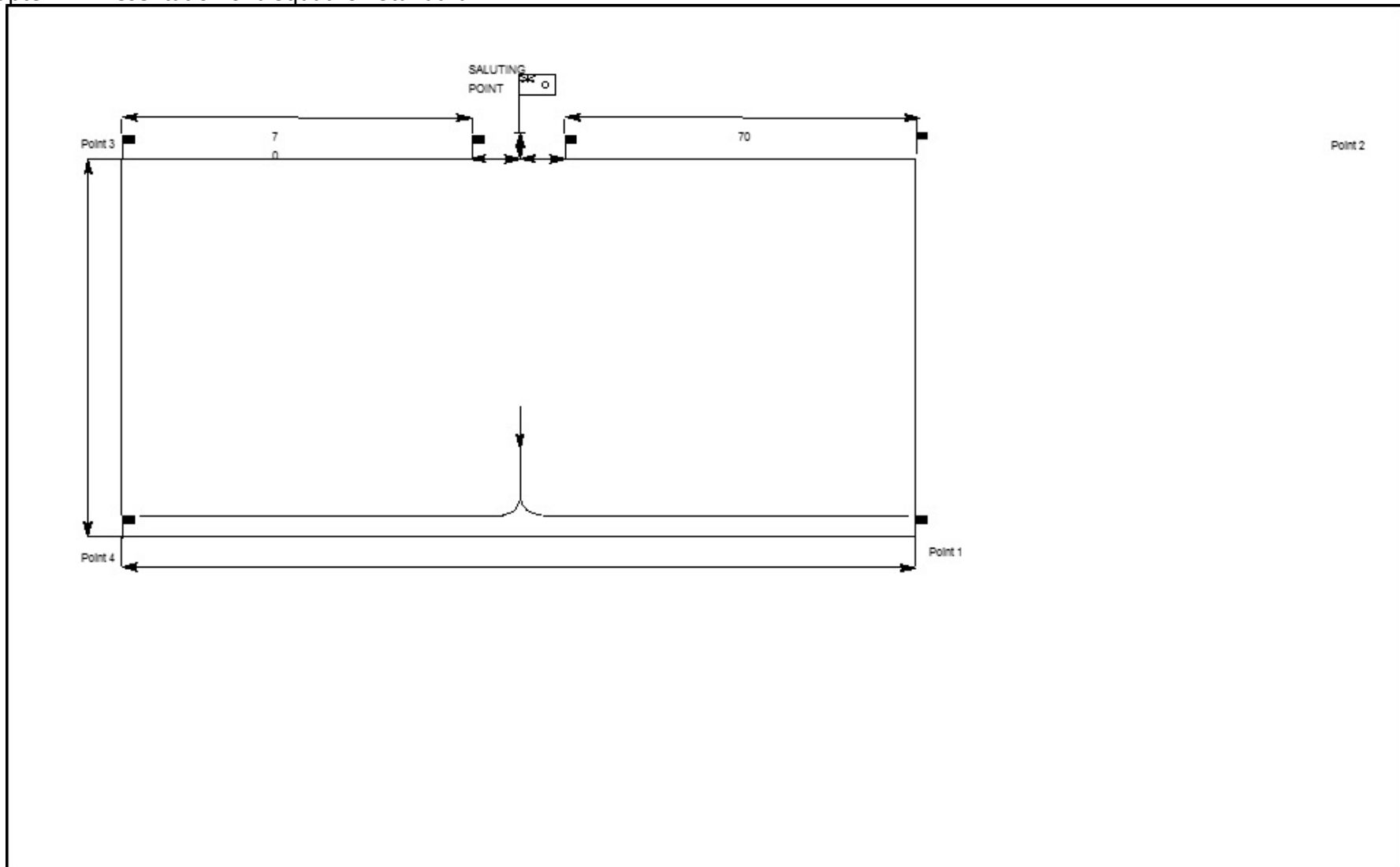

Figure 4-7-3 Parade Positions and Markers C

UNCLASSIFIED

Chapter 8 – King's Birthday Parade without Queen's Colour

4.8.1 King's birthday parade

- a. Squadrons are to be formed up on their own predetermined assembly area where they are to be sized and inspected as for squadron drill (refer to Part 2, [Chapter 3](#)).
- b. The procedure for the Sovereign's Birthday parade without the Queen's Colour (QC) is shown in Table [4-8-1](#).

Table 4-8-1 Procedure for the Sovereign's Birthday Parade without the Queen's Colour

| Serial | Commander | Command | Action |
|--------|-----------|--|---|
| 1 | | | <ul style="list-style-type: none"> – When the advance is sounded, SCDRs march their squadrons onto the parade ground from the reverse flank. – As each squadron advances onto the parade ground |
| 2 | SCDR | AT THE HALT FACING LEFT FORM CLOSE COLUMN OF FLIGHTS | |
| 3 | FLTCDRs | NO..... FLIGHT – HALT (IN LINE WITH THE MARKER). NO..... FLIGHT WILL ADVANCE LEFT – TURN | – Each FLTCDR does the same at the appropriate time. |
| 4 | | – When each squadron is in position— | |
| | SCDR | SQUADRON STAND AT – EASE | |
| 5 | | – PADJ takes up their position 15 paces in the front centre of the wing | |
| | PADJ | PARADE PARADE – SHUN OFFICERS WILL TAKE POST IN REVIEW ORDER OUTWARDS – TURN QUICK – MARCH INWARDS – TURN PARADE IN OPEN ORDER – RIGHT DRESS (ACTIONS TO BE AS FOR NORMAL WING PARADE) EYES – FRONT | |
| 6 | | <ul style="list-style-type: none"> – The PADJ— – turns about; – hands the parade over to the PCDR; and – takes up their position. | |
| 7 | PCDR | PARADE STAND AT EASE | |

UNCLASSIFIED

NZAP 2.4 Manual of Ceremonial and Drill
 Part 4 - Queen's Colour and Squadron Standard Ceremonial Drill
 Chapter 8 – King's Birthday Parade without Queen's Colour

Version 6.00
 13 June 2023

| Table 4-8-1 Procedure for the Sovereign's Birthday parade without the Queen's Colour (cont.) | | | |
|---|--|--|---|
| Serial | Commander | Command | Action |
| 8 | – As the reviewing officer arrives— | | |
| | PCDR | PARADE PARADE – SHUN | |
| 9 | – When the reviewing officer is in position on the dais— | | |
| | PCDR | GENERAL SALUTE PRESENT – ARMS SHOULDER – ARMS | |
| 10 | – Inspection (refer to Table 3-3-1). | | |
| 11 | – After the inspection by the reviewing officer— | | |
| | PCDR | PARADE CLOSE ORDER – MARCH OFFICERS WILL TAKE POST LEFT TURN QUICK MARCH INWARDS TURN PARADE WILL MARCH PAST BY SQUADRONS IN COLUMN OF ROUTE AND PAY COMPLIMENTS BY FLIGHTS MOVE TO THE RIGHT IN THE COLUMN OF ROUTE RIGHT – TURN | <ul style="list-style-type: none"> – All officers, warrant officers (W/Os) and supernumerary officers take up their positions. – When the PCDR is in position, No.1 Flight commander of No.1 Squadron steps their flight off. |
| 12 | – As the parade approaches the saluting area— | | |
| | PCDR | BY THE RIGHT SQUADRON WILL PAY COMPLIMENTS BY FLIGHTS | |
| 13 | – Just before each flight reaches the saluting area— | | |
| | FLTCDR | NO.... FLIGHT EYES – RIGHT | – No.1 Flight commander allows for distance of personnel in front. |
| 14 | – When supernumerary officers of each flight have passed the saluting area— | | |
| | FLTCDR | NO.... FLIGHT EYES – FRONT | – Succeeding squadrons and flights are to act similarly. |
| 15 | <ul style="list-style-type: none"> – The PCDR leads the parade back to the original position on the parade ground by executing two left wheels. – The PCDR breaks formation and resumes their position in the centre of the parade ground. | | |
| 16 | – As squadrons approach their original positions on the parade ground— | | |
| | PCDR | AT THE HALT FACING LEFT FORM CLOSE COLUMN OF FLIGHTS | – Flights act as in squadron drill. |

UNCLASSIFIED

UNCLASSIFIED

NZAP 2.4 Manual of Ceremonial and Drill
 Part 4 - Queen's Colour and Squadron Standard Ceremonial Drill
 Chapter 8 – King's Birthday Parade without Queen's Colour

Version 6.00
 13 June 2023

| Table 4-8-1 Procedure for the Sovereign's Birthday parade without the Queen's Colour (cont.) | | | |
|---|---|--|--|
| Serial | Commander | Command | Action |
| 17 | – When the parade is reformed— | | |
| | PCDR | PARADE OFFICERS WILL TAKE POST IN REVIEW ORDER OUTWARDS TURN – QUICK MARCH INWARDS – TURN PARADE RIGHT – DRESS EYES FRONT PARADE WILL ADVANCE IN REVIEW ORDER BY THE CENTRE QUICK – MARCH | |
| 18 | – When the parade is halted— | | |
| | PCDR | GENERAL SALUTE PRESENT – ARMS SHOULDER – ARMS | |
| 19 | – The reviewing officer and others in attendance move onto the parade ground. | | |
| 20 | PCDR | ROYAL SALUTE PRESENT – ARMS | |
| 21 | PCDR | SHOULDER – ARMS PARADE WILL REMOVE HEADDRESS REMOVE – HEADDRESS | – The left hand grasps the peak of the headdress between thumb and forefingers |
| 22 | PCDR | THREE CHEERS FOR HIS MAJESTY THE KING HIP-HIP-HURRAY HIP-HIP-HURRAY HIP-HIP-HURRAY | – The headdress is placed over the chest and is raised to full arms' length as each cheer is given |
| 23 | PCDR | PARADE WILL REPLACE HEADDRESS REPLACE – HEADDRESS PARADE ROYAL SALUTE PRESENT ARMS | – During the salute the sovereign's personal flag for New Zealand is lowered in time with the playing of the first verse of British Nation Anthem. |
| 24 | PCDR | SHOULDER – ARMS | |
| 25 | – There are options for what follows the lowering of the Sovereign's personal flag for New Zealand. Actions and commands are, therefore, to be adapted to suit requirements, for example— <ul style="list-style-type: none"> – medal presentations and address (refer to serials 26 and 27 of this table); – medal presentation but no address; – address but no medal presentation; or – neither medal presentation nor address. | | |

UNCLASSIFIED

UNCLASSIFIED

NZAP 2.4 Manual of Ceremonial and Drill

Version 6.00

Part 4 - Queen's Colour and Squadron Standard Ceremonial Drill

13 June 2023

Chapter 8 – King's Birthday Parade without Queen's Colour

| Table 4-8-1 Procedure for the Sovereign's Birthday parade without the Queen's Colour (cont.) | | | |
|---|--|---|---|
| Serial | Commander | Command | Action |
| 26 | – When the reviewing officer has returned to the dais— | | |
| | PCDR | PARADE STAND AT – EASE MARCH ON THE RECIPIENTS | <ul style="list-style-type: none"> – Commanded by the senior recipient, the medal recipients— <ul style="list-style-type: none"> – march on; – halt; – advance; – dress; and – stand at ease. – After the presentation the recipients remain in front of the dais for the address by the reviewing officer. |
| 27 | When the address concludes— | | |
| | PCDR | PARADE PARADE – SHUN MARCH OFF THE RECIPIENTS | <ul style="list-style-type: none"> – The recipients march off commanded by the senior recipient. |
| 28 | <ul style="list-style-type: none"> – The reviewing officer retires from the parade ground to their waiting vehicle. – When the vehicle door is closed— | | |
| | PCDR | GENERAL SALUTE PRESENT – ARMS | <ul style="list-style-type: none"> – Other VIPs leave the parade area in turn. |
| 29 | When all the VIPs' vehicles have left the parade area | | |
| | PCDR | SHOULDER – ARMS SQUADRON COMMANDERS MARCH YOUR SQUADRONS TO YOUR PARADE GROUND AND DISMISS | <ul style="list-style-type: none"> – SCDRs— <ul style="list-style-type: none"> – salute; – march their squadrons off the parade ground independently; and – dismiss their squadron as in normal drill. |

4.8.2 Wet weather format

The wet weather format is as follows—

- (1) Escort squadron (if Sqns is present) is reduced to two flights.
- (2) Support squadrons are reduced to personnel flanking the indoor venue in single rank.
- (3) Escort squadron falls in on its predetermined position.
- (4) Sqns forms up on the right flank and marches on.

Note: Where there is more than one Sqns to consider and the QC, then space will dictate composition and whether or not all will parade.

- (5) Reviewing officer is received.
- (6) Inspection.

UNCLASSIFIED

NZAP 2.4 Manual of Ceremonial and Drill
Part 4 - Queen's Colour and Squadron Standard Ceremonial Drill
Chapter 8 – King's Birthday Parade without Queen's Colour

Version 6.00
13 June 2023

- (7) Abbreviated Advance in Review Order.
- (8) Sovereign's personal flag for New Zealand broken at masthead.
- (9) Three cheers for His/Her Majesty.
- (10) Presentation of awards, if any.
- (11) Address by reviewing officer, if given.
- (12) Departure of reviewing officer.
- (13) SqnS is marched off.
- (14) Escort squadron is dismissed.
- (15) Support personnel are dismissed.

Chapter 9 – Parading the Queen's Colour on His Majesty's Official Birthday with Support Squadrons

Section 1 – Support squadrons armed

4.9.1 Sequence of parade

- a. The support squadrons march on.
- b. The escort squadron marches on.
- c. The Queen's Colour (QC) is marched on.
- d. The parade presents arms.
- e. The reviewing officer arrives.
- f. General/Royal salute.
- g. Inspection by the reviewing officer.
- h. The QC is paraded by No.2 Flight of the escort squadron through the ranks of the support squadrons.
- i. The escort squadron prepares for the ceremonial of the review.
- j. Ceremonial by the band.
- k. Ceremonial review of the QC by the escort squadron—
 - (1) squadron marches past, by the flights, in slow time;
 - (2) squadron marches past in quick time; then
 - (3) squadron advances in review order (Royal Salute).
- l. The reviewing officer leaves the dais and stands to the right of the flagpole, and salutes when the sovereign's personal flag for New Zealand is broken at the masthead.
- m. The parade gives three cheers for His Majesty the King.
- n. The British National Anthem is played. (Royal Salute)
- o. The sovereign's personal flag for New Zealand is lowered;
- p. Reviewing officer returns to dais.
- q. March past by the entire parade.
- r. March past by the band.

UNCLASSIFIED

NZAP 2.4 Manual of Ceremonial and Drill

Version 6.00

Part 4 - Queen's Colour and Squadron Standard Ceremonial Drill

13 June 2023

Chapter 9 – Parading the QC on His Majesty's Official Birthday with Support Squadrons

4.9.2 Parade composition

The parade comprises—

- (1) parade commander (PCDR).
- (2) parade adjutant (PADJ) (takes post in front of No.1 support squadron).
- (3) Parade warrant officer (PWO).
- (4) an escort squadron, comprising—
 - (a) one SCDR;
 - (b) three FLTCDRs;
 - (c) one QCP; and
 - (d) three flights, each of four SNCO guides and markers, with corporals (CPLs) and ORs in the ranks.
- (5) support squadrons, each comprising—
 - (a) one SCDR per squadron;
 - (b) one squadron adjutant (SADJ) per squadron;
 - (c) three FLTCDRs per squadron;
 - (d) one supernumerary officer per flight; and
 - (e) three flights per squadron, each of four non-commissioned officer (NCO) guides and markers, with ORs in the ranks.

4.9.3 Dress

- a. Officers/warrant officers (W/Os) wear No.1A Service Dress, medals, swords and white gloves.
- b. Support squadrons wear No.1A Service Dress, orders, decorations and medals.
- c. Other ranks (ORs) wear No.1A Service Dress, medals, rifles fitted with white slings, bayonets and white gloves.
- d. The Queen's Colour Party (QCP), all wearing white gloves, consists of—
 - (1) the Queen's Colour bearer (QCB);
 - (2) the QC W/O (QCB and QC W/O both wear swords); and
 - (3) two senior non-commissioned officers (SNCOs) armed with rifles with bayonets fitted and with white slings.

UNCLASSIFIED

NZAP 2.4 Manual of Ceremonial and Drill

Version 6.00

Part 4 - Queen's Colour and Squadron Standard Ceremonial Drill

13 June 2023

Chapter 9 – Parading the QC on His Majesty's Official Birthday with Support Squadrons

4.9.4 Parade formation

The parade consists of—

- (1) one escort squadron of three flights; and
- (2) up to four support squadrons each of three flights.

Note: Personnel constraints can make the above a difficult formation to achieve. More commonly, and more practically, the best option is two support squadrons with flights in line, each squadron marking the right and left flanks of the parade ground.

4.9.5 Parade form up

- a. Squadrons are paraded on their own predetermined assembly areas, where they are sized and inspected as for squadron drill (refer to Part 2, [Chapter 3](#)).
- b. Squadron markers are positioned on the ceremonial parade ground by the PWO before the parade.
- c. The escort squadron forms up in line of flights on the receiving base.
- d. The support squadrons form up in line of squadrons in close column of flights 14 paces behind the receiving base.
- e. The band takes up position in the centre and to the rear of the parade.
- f. The procedure for forming up the parade is as shown in Table [4-9-1](#).

| Serial | Commander | Command | Action |
|--------|-----------|---|--|
| 1 | | | <ul style="list-style-type: none"> – When the SCDRs have inspected their respective squadrons— – command their officers to draw swords; – march their squadrons onto their markers in column of route on the ceremonial parade ground from the reverse flank. |
| 2 | SCDR | PARADE STAND AT – EASE ESCORT SQUADRON TAKE POST | <ul style="list-style-type: none"> – The parade stands at ease – The escort squadron— – marches on to the marker in column of route; and – forms a line of flights on the receiving base. |
| 3 | SCDR | STAND AT – EASE | <ul style="list-style-type: none"> – The escort squadron stands at ease |

UNCLASSIFIED

NZAP 2.4 Manual of Ceremonial and Drill

Version 6.00

Part 4 - Queen's Colour and Squadron Standard Ceremonial Drill

13 June 2023

Chapter 9 – Parading the QC on His Majesty's Official Birthday with Support Squadrons

| Serial | Commander | Command | Action |
|--------|---|---|---|
| 4 | – When all the squadrons are in position— | | |
| | PADJ | PARADE PARADE – SHUN FORM TWO – RANKS WITHOUT INTERVALS – IN OPEN ORDER RIGHT – DRESS EYES – FRONT STAND AT – EASE | |
| 5 | – As the PCDR arrives— | | |
| | PADJ | PARADE PARADE – SHUN | – PADJ reports to the PCDR— <i>'Parade present, Sir/Ma'am'</i> |

4.9.6 Ceremonial

The procedure for the sovereign's official birthday celebration with parading the Queen's Colour is shown in Table [4-9-2](#).

Table 4-9-2 Procedure for Parading the Queen's Colour on the Sovereign's Official Birthday

| Serial | Commander | Command | Action |
|--------|--|--|---|
| 1 | PCDR | OFFICERS TAKE POST IN REVIEW ORDER OUTWARDS – TURN QUICK – MARCH OFFICERS LEFT – TURN | – Officers are to act as detailed in Part 2, Chapter 4 <i>Review of a Wing</i> . – The QC, which is positioned at the extreme left flank of the parade, is marched on. |
| 2 | PCDR | PARADE PARADE – SHUN MARCH ON THE QUEEN'S COLOUR PRESENT – ARMS | – The QC is marched on under the command of the QCB. – All officers and W/Os salute. |
| 3 | – When the QC is in position in front of No.2 Flight of the escort squadron— | | |
| | PCDR | PARADE SHOULDER – ARMS STAND AT – EASE | – Officers and W/Os complete the salute. – The parade is now ready to receive the reviewing officer. |
| 4 | – When the reviewing officer reaches a position about 45 m from the saluting base— | | |
| | PCDR | PARADE PARADE – SHUN | |
| 5 | – When the reviewing officer has taken up position on the dais— | | |
| | PCDR | GENERAL SALUTE PRESENT – ARMS | Note: If the parade is being inspected by a Royal personage the command is to be— <i>'ROYAL SALUTE, PRESENT – ARMS'</i> |

UNCLASSIFIED

UNCLASSIFIED

NZAP 2.4 Manual of Ceremonial and Drill

Version 6.00

Part 4 - Queen's Colour and Squadron Standard Ceremonial Drill

13 June 2023

Chapter 9 – Parading the QC on His Majesty's Official Birthday with Support Squadrons

| Table 4-9-2 Procedure for Parading the Queen's Colour on the Sovereign's Official Birthday (cont.) | | | |
|---|--|---|---|
| Serial | Commander | Command | Action |
| 6 | – After the band has played the appropriate salute— | | |
| | PCDR | PARADE SHOULDER – ARMS | – The PCDR reports to the reviewing officer that the parade is ready for inspection. |
| 7 | PCDR | ESCORT SQUADRON STAND FAST SUPPORT SQUADRONS STAND AT – EASE | – The escort squadron is normally inspected on foot and the support squadrons in an open vehicle. |
| 8 | – After the inspection of the escort squadron, as the reviewing officer's approaches each support squadron— | | |
| | Each support squadron commander (SSqncDR) | NO.... SQUADRON NO.... SQUADRON – SHUN | – The respective SSqn comes to attention while they are inspected. |
| 9 | – After each support squadron has been inspected and the reviewing officer has moved on to inspect the next support squadron— | | |
| | Each SSqncDR | NO.... SQUADRON STAND AT – EASE | – Each SSqn returns to the 'at ease' position. |
| 10 | – At the end of the inspection, the PCDR— – requests permission to parade the QC; then – returns to their original position. | | |
| Parading the QC | | | |
| Where appropriate, the QC can be paraded along the front ranks of the escort squadron and support squadrons returning to its place in front of the escort squadron. | | | |
| Note: Parading the QC is not mandatory. | | | |
| – If the QC is to be paraded— | | | |
| 11 | PCDR | PARADE PARADE – SHUN ESCORT SQUADRON COMMANDER PARADE THE QUEEN'S COLOUR | – The QC is paraded by the QCP acting independently and marching along the front ranks of support squadrons and returning to their position in the escort squadron. (Refer to Table 4-5-4) |
| The review (including the march past in column of flights and the advance in review order) | | | |
| 12 | PCDR | ESCORT SQUADRON COMMANDER PREPARE YOUR SQUADRON FOR THE REVIEW | |

UNCLASSIFIED

UNCLASSIFIED

NZAP 2.4 Manual of Ceremonial and Drill

Version 6.00

Part 4 - Queen's Colour and Squadron Standard Ceremonial Drill

13 June 2023

Chapter 9 – Parading the QC on His Majesty's Official Birthday with Support Squadrons

| Table 4-9-2 Procedure for Parading the Queen's Colour on the Sovereign's Official Birthday (cont.) | | | |
|---|---|--|---|
| Serial | Commander | Command | Action |
| 13 | PCDR | OFFICERS TAKE POST LEFT – TURN QUICK – MARCH INWARDS – TURN ESCORT SQUADRON CLOSE ORDER – MARCH FORM THREE – RANKS RIGHT – DRESS EYES – FRONT FORM CLOSE COLUMN OF FLIGHTS MOVE TO THE RIGHT IN COLUMN OF THREES RIGHT – TURN | <ul style="list-style-type: none"> – The QCP, under the orders of the QCB, takes up position between No.1 and No. 2 flights. – The PCDR turns to the left. |
| 14 | PCDR | BY THE LEFT QUICK – MARCH | <ul style="list-style-type: none"> – The PCDR— – marches forward; – takes post opposite the left flank of No.2 Squadron; and – turns to the left. |
| 15 | – When the leading flight of the escort squadron is abreast of Point 1— | | |
| | Escort SCDR | CHANGE DIRECTION LEFT LEFT WHEEL AT THE HALT FACING LEFT FORM CLOSE COLUMN OF FLIGHTS | <ul style="list-style-type: none"> – No. 1 flight left wheels at Point 1, – The QCP left wheels seven paces beyond Point 1. – No. 2 Flight left wheels a further seven paces beyond the QCP. <p>Note: If a SqnS is also being paraded, the SqnSP left wheels seven paces beyond No. 2 Flight.</p> <p>Note: If multiple SqnSs are being paraded, their escort flights are to left wheel at further 7 pace intervals.</p> <ul style="list-style-type: none"> – FLTCDRs halt their flights independently at Point 2 and turn into line. – The QCP, under the orders of the QCB, wheels into position centrally between No. 1 and No. 2 flights. |
| 16 | Escort SCDR | ESCORT SQUADRON RIGHT – DRESS EYES – FRONT | |
| 17 | PCDR | PARADE STAND AT – EASE | <ul style="list-style-type: none"> – On the last word of the command, the band performs a musical troop. – On the completion of the troop, the band takes post with their front rank in line with the front ranks of the support squadrons. |

UNCLASSIFIED

UNCLASSIFIED

NZAP 2.4 Manual of Ceremonial and Drill

Version 6.00

Part 4 - Queen's Colour and Squadron Standard Ceremonial Drill

13 June 2023

Chapter 9 – Parading the QC on His Majesty's Official Birthday with Support Squadrons

| Table 4-9-2 Procedure for Parading the Queen's Colour on the Sovereign's Official Birthday (cont.) | | | |
|---|--|--|--|
| Serial | Commander | Command | Action |
| 18 | – When the band is in position, the PCDR is to returns to their original position— | | |
| | PCDR | PARADE PARADE – SHUN | |
| 19 | PCDR | ESCORT SQUADRON SHOULDER ARMS ESCORT SQUADRON WILL MARCH PAST BY FLIGHTS IN COLUMN IN SLOW TIME AT 25 PACES DISTANCE BY THE RIGHT | |
| 20 | No.1 FLTCDR | NO. 1 FLIGHT BY THE RIGHT SLOW – MARCH | – The QCP with No. 2 Flight follow at 25 paces distance, followed by any remaining flights at further 25 pace intervals. |
| 21 | – When the flights are in position— | | |
| | FLTCDRs | EYES – RIGHT EYES – FRONT | – The QCP acts on the orders of No. 2 FLTCDR. |
| 22 | – When the leading flight approaches their predetermined mark— | | |
| | PCDR | PARADE AT THE HALT FORM CLOSE COLUMN OF FLIGHTS | |
| 23 | – When the right marker of No. 1 Flight arrives at a predetermined mark— | | |
| | No. 1 FLTCDR | NO. 1 FLIGHT – HALT | – The remaining flights are halted to form close column of flights on the leading flight. |
| 24 | – When the formation is completed— | | |
| | PCDR | ESCORT SQUADRON ABOUT – TURN | <ul style="list-style-type: none"> – Escort squadron officers— <ul style="list-style-type: none"> – turn about; and – take up their position in quick time. – The QCP, under the orders of the QCB, marches to its position beyond No.2 Flight. – PCDR takes up position in front of the squadron. |
| 25 | PCDR | ESCORT SQUADRON LEFT – DRESS EYES – FRONT | <ul style="list-style-type: none"> – Officers take post as before. – The QCP remains between No. 1 and No. 2 flights. <p>Note: If there are more than two flights being paraded, the QC is positioned to the rear of No. 2 Flight.</p> |

UNCLASSIFIED

NZAP 2.4 Manual of Ceremonial and Drill

Version 6.00

Part 4 - Queen's Colour and Squadron Standard Ceremonial Drill

13 June 2023

Chapter 9 – Parading the QC on His Majesty's Official Birthday with Support Squadrons

| Table 4-9-2 Procedure for Parading the Queen's Colour on the Sovereign's Official Birthday (cont.) | | | |
|---|--|---|---|
| Serial | Commander | Command | Action |
| 26 | PCDR | SUPPORT SQUADRONS STAND AT – EASE SUPPORT SQUADRONS SUPPORT SQUADRONS – SHUN | |
| 27 | PCDR | ESCORT SQUADRON WILL MARCH PAST IN CLOSE COLUMN OF FLIGHTS BY THE LEFT QUICK – MARCH | |
| 28 | – When the leading flight approaches the predetermined mark— | | |
| | FLTCDR | SQUADRON, EYES – LEFT | |
| 29 | – As the rear rank of the rear flight approaches the predetermined mark— | | |
| | FLTCDR | EYES – FRONT | |
| 30 | – When the rear rank of the rear flight approaches the predetermined mark— | | |
| | FLTCDR | SQUADRON – HALT ABOUT – TURN | <ul style="list-style-type: none"> – Officers take post as before. – The QCP remains between Nos.1 and 2 flights. <p>Note: If there are more than two flights being paraded, the QC is positioned to the rear of No. 2 Flight.</p> |
| 31 | Escort SCDR | SQUADRON FORM LINE OF FLIGHTS ON THE RECEIVING BASE MOVE TO THE LEFT IN COLUMN OF THREES LEFT – TURN | <ul style="list-style-type: none"> – The QCP, under the orders of the QCB, takes up position by left wheeling beyond No.2 Flight. |
| 32 | FLTCDRs of subsequent flights | NO... FLIGHT BY THE RIGHT QUICK – MARCH | |
| 33 | – As the leading guide of each flight approaches the predetermined mark— | | |
| | FLTCDR | NO ___ FLIGHT CHANGE DIRECTION RIGHT RIGHT WHEEL | <ul style="list-style-type: none"> – The QCP acts on the command of the QCB. |
| 34 | – As a squadron arrives at its original position on the receiving base— | | |
| | PCDR | ESCORT SQUADRON – HALT SQUADRON WILL ADVANCE RIGHT – TURN | <ul style="list-style-type: none"> – The QCP takes up position on the orders of the QCB. |

UNCLASSIFIED

UNCLASSIFIED

NZAP 2.4 Manual of Ceremonial and Drill

Version 6.00

Part 4 - Queen's Colour and Squadron Standard Ceremonial Drill

13 June 2023

Chapter 9 – Parading the QC on His Majesty's Official Birthday with Support Squadrons

| Table 4-9-2 Procedure for Parading the Queen's Colour on the Sovereign's Official Birthday (cont.) | | | |
|---|---------------------------------|--|---|
| Serial | Commander | Command | Action |
| 35 | PCDR | ESCORT SQUADRON RIGHT – DRESS EYES – FRONT OFFICERS TAKE POST IN REVIEW ORDER OUTWARDS – TURN QUICK – MARCH OFFICERS LEFT – TURN | |
| 36 | PCDR | PARADE STAND AT – EASE | |
| 37 | After an interval of 30 seconds | | |
| | PCDR | PARADE PARADE – SHUN | |
| 38 | PCDR | PARADE SHOULDER – ARMS | <ul style="list-style-type: none"> – The reviewing officer— – leaves the dais; and – takes up position standing to the left and facing the flagpole. |
| 40 | PCDR | PARADE WILL ADVANCE IN REVIEW ORDER BY THE CENTRE QUICK – MARCH | |
| 41 | PCDR | PARADE ROYAL SALUTE PRESENT – ARMS | |
| 42 | PCDR | PARADE WILL REMOVE HEADDRESS REMOVE – HEADDRESS | |
| 43 | PCDR | THREE CHEERS FOR HIS MAJESTY THE KING HIP-HIP-HURRAY HIP-HIP-HURRAY HIP-HIP-HURRAY | |
| 44 | PCDR | PARADE WILL REPLACE HEADDRESS REPLACE – HEADDRESS | |
| 45 | PCDR | ESCORT SQUADRON ROYAL SALUTE PRESENT – ARMS SHOULDER – ARMS | |
| The march past | | | |

UNCLASSIFIED

UNCLASSIFIED

NZAP 2.4 Manual of Ceremonial and Drill

Version 6.00

Part 4 - Queen's Colour and Squadron Standard Ceremonial Drill

13 June 2023

Chapter 9 – Parading the QC on His Majesty's Official Birthday with Support Squadrons

| Table 4-9-2 Procedure for Parading the Queen's Colour on the Sovereign's Official Birthday (cont.) | | | |
|---|--|--|--|
| Serial | Commander | Command | Action |
| 46 | <ul style="list-style-type: none"> - The PCDR requests permission from the reviewing officer for the parade to march past. - Having received permission— | | |
| | PCDR | OFFICERS TAKE POST LEFT – TURN QUICK – MARCH OFFICERS INWARDS – TURN | |
| 47 | PCDR | SUPPORT SQUADRONS CLOSE ORDER – MARCH FORM THREE – RANKS RIGHT – DRESS EYES – FRONT | |
| 48 | PCDR | ESCORT SQUADRON WILL MARCH PAST BY FLIGHTS IN COLUMN AT 25 PACES DISTANCE ESCORT SQUADRON LEADING WILL MOVE TO THE RIGHT IN COLUMN OF THREES RIGHT – TURN | <ul style="list-style-type: none"> - The QCP on the orders of the QCB, takes up position between Nos.1 and 2 flights of the escort squadron. - The PCDR, PADJ and PWO position themselves in front of the escort party CDR, facing right, with the PADJ and PWO in front of the PCDR, so that, on turning into line, they are correctly aligned for the march past. - The PCDR, PADJ and PWO are to march past then fall out. |
| 49 | PCDR | ESCORT SQUADRON BY THE LEFT QUICK – MARCH | |
| 50 | FLTCDRs, in succession | NO.... FLIGHT BY THE LEFT QUICK – MARCH | |
| 51 | <ul style="list-style-type: none"> - As each flight approaches the predetermined mark— | | |
| | FLTCDR | NO.... FLIGHT CHANGE DIRECTION LEFT LEFT WHEEL | |
| 52 | <ul style="list-style-type: none"> - As each flight approaches the predetermined mark— | | |
| | FLTCDR | FLIGHT WILL ADVANCE LEFT – TURN BY THE RIGHT | |
| 53 | <ul style="list-style-type: none"> - As each flight approaches the predetermined mark— | | |
| | FLTCDR | NO.... FLIGHT EYES – RIGHT | |

UNCLASSIFIED

UNCLASSIFIED

NZAP 2.4 Manual of Ceremonial and Drill

Version 6.00

Part 4 - Queen's Colour and Squadron Standard Ceremonial Drill

13 June 2023

Chapter 9 – Parading the QC on His Majesty's Official Birthday with Support Squadrons

| Serial | Commander | Command | Action |
|---------------|---|--------------------------------------|--|
| 54 | As each flight approaches the predetermined mark— | | |
| | FLTCDR | NO... FLIGHT EYES – FRONT | <ul style="list-style-type: none"> – The parade marches past the reviewing officer – The squadrons march independently to their respective assembly areas, where they are dismissed. |

*Section 2 – Support squadrons unarmed***4.9.7 Sequence of parade**

The sequence for the unarmed parade is as for the armed parade as listed in paragraph [4.9.1f.–r.](#)

4.9.8 Parade composition

The composition of the unarmed parade is as for the armed parade as described in paragraph [4.9.2.](#)

Note: SADJs take post as supernumerary officers with No.1 Flight of their squadron.

4.9.9 Dress

- a. The dress of an unarmed parade is as for the armed parade as described in paragraph [4.9.3](#) except that—Officers and W/O's wear black gloves.
- b. Support squadrons wear No.1A Service Dress do not carry rifles.

4.9.10 Parade formation

The formation for an unarmed parade is as for the armed parade as described in paragraph [4.9.4.](#)

4.9.11 Parade form up

The form up for an unarmed parade is as described in Table [4-9-1.](#)

4.9.12 Ceremonial

The Ceremonial for the unarmed parade is as for the armed parade except that:

- (1) Only the Escort Squadron advances in review order at Table [4-9-2](#), Serial 39.
- (2) Only the Escort Squadron presents and shoulders arms at Table [4-9-2](#), serials 40 and 41 respectively.

Chapter 10 – Freedom of Entry to a City or Town

4.10.1 Introduction

Paragraphs [4.10.2](#) and [4.10.3](#) provide a brief historical background to the ancient custom whereby a City may formally grant a unit certain privileges and a guide for unit action. These privileges often referred to as the Freedom of the City, and include, as a rule, the right to march ceremonially through the city with Colours flying, drums beating and bayonets fixed to rifles without further formal permission from the municipal authorities. The absence of such special privileges in no way abrogates the power or right of a unit or formation of His Majesty's Forces to enter any city with bayonets fixed, if necessitated by operations or civil disturbances.

4.10.2 Historical background

- a. In the United Kingdom certain cities/boroughs have a statutory right to admit as 'Honorary Freemen', persons of distinction and persons who have rendered eminent service to the city/borough. Associated with their right, but authorised by statute, is the right of 'Freedom of Entry' occasionally granted to units, which has been widely followed throughout the Commonwealth. It provides a dignified and satisfactory means of enabling a municipal authority to honour a distinguished unit, thereby affecting a very desirable liaison between the local authority and the Armed Forces.
- b. The granting of Freedom by a City/Borough is a privilege that should not be given or accepted lightly. While the honour of such privilege is recognised, nevertheless it is desirable that the privilege should be restricted to a unit/base, the base commander (BCDR) of which is of the rank of Group Captain (GPCAPT), having a close association with a local body. It is also desirable that the local body granting the privilege should be of at least a city or borough status.

4.10.3 Granting of freedom

- a. While the granting and acceptance of the Freedom of the City is a domestic matter to be resolved between the local authority and the unit concerned, nevertheless, the custom involves obligation as well as privileges. Therefore acceptance of freedom privileges by any unit or establishment will be subject to approval by Air Staff. Their approval will be based on—
 - (1) the length of association of the unit within the community; and
 - (2) the degree to which the unit has been supported by the local body and community.
- b. As soon as a unit is approached by a local body, the BCDR should prepare a submission, giving the outline of the proposal with supporting background information, and forward the submission through normal channels to Air Staff for approval-in-principle to conduct further discussions with the local body.

UNCLASSIFIED

NZAP 2.4 Manual of Ceremonial and Drill
Part 4 - Queen's Colour and Squadron Standard Ceremonial Drill
Chapter 10 – Freedom of Entry to a City or Town

Version 6.00
13 June 2023

- c. Once approval has been received and the local body council has passed the required resolution, the unit is to submit a formal proposal to Air Staff for approval by Chief of Air Force (CAF). Their proposal should include the formal invitation from the local body to confer the freedom. The form of Charter to be presented to the unit is shown in Figure [4-10-1](#).

4.10.4 General

- a. It is difficult to lay down a fixed pattern for a Freedom of Entry parade given that the parade area and number of personnel involved will vary considerably. The following instructions are to be adhered to as closely as reasonably practicable and have been drafted to include—
 - (1) The Queen's Colour (QC) and a Squadron Standard (SqnS) being paraded together.
 - (2) An aircraft fly past.
- b. The parade is to be sized and inspected before departure.
- c. Depending on the venue, the parade is to be marched on to the parade area, escort squadron leading, so that—
 - (1) the completed parade is formed up with support squadrons in close column of flights and the escort squadron in front, in line of flights;
 - (2) the squadron parading the SqnS is to be No.1 Squadron;
 - (3) the Queen's Colour party (QCP), Squadron Standard party (SqnSP) and Scroll party are formed up 20 paces from the left flank and facing the centre, in a line, with the—
 - (a) QCP on the right;
 - (b) SqnSP in the centre; and
 - (c) Scroll party on the left.
 - (4) the band on the right flank facing the centre.

4.10.5 Forming up

- a. Squadrons are to be paraded on their own assembly areas where they are sized, dressed and inspected as for squadron drill. (Refer to Part 2, [Chapter 3](#).)
- b. Bayonets are to be fixed informally before falling in.
- c. Squadron markers are to be prepositioned on the ceremonial parade ground by the parade warrant officer (PWO).
- d. The PADJ is to order the trumpeters to sound the 'Advance'.
- e. Squadrons are to be marched on to the ceremonial parade ground and stood at ease.

UNCLASSIFIED

4.10.6 Parade ceremony

The procedure for the Freedom of the City parade is shown in Table [4-10-1](#).

Table 4-10-1 Procedure for the Freedom of the City Parade

| Serial | Commander | Command | Action |
|-------------------|--|--|---|
| 1 | – When all of the squadrons are in position— | | |
| | PADJ | PARADE PARADE – SHUN RIGHT – DRESS EYES – FRONT STAND AT – EASE | – Parade stands at ease awaiting the arrival of the PCDR. |
| 2 | – On the arrival of the PCDR— | | |
| | PADJ | PARADE PARADE – SHUN | – Parade comes to attention – The PADJ reports for the PCDR <i>‘Sir/Ma’am, parade present.’</i> – The PADJ moves to their position in line with the Escort SCDR. |
| 3 | PCDR | OFFICERS DRAW SWORDS OFFICERS TAKE POST IN REVIEW ORDER OUTWARDS – TURN QUICK – MARCH OFFICERS LEFT – TURN PARADE IN OPEN ORDER RIGHT – DRESS EYES – FRONT PARADE STAND AT – EASE | – The parade stands at ease as it awaits the arrival of the Mayor. |
| Ceremonial | | | |
| 4 | – As the Mayor approaches— | | |
| | PCDR | PARADE PARADE – SHUN | |
| 5 | – When the Mayor is in position on the dais— | | |
| | PCDR | GENERAL SALUTE PRESENT – ARMS | – The band plays the general salute. |
| 6 | PCDR | SHOULDER – ARMS | – The PCDR then goes forward and presents the parade to the Mayor for inspection. – While the Mayor is inspecting the parade, the band plays appropriate music. |
| 7 | – On completion of the inspection— | | |
| | PCDR | PARADE STAND AT – EASE | – The freedom ceremony begins. – The Mayor addresses the parade. |

UNCLASSIFIED

UNCLASSIFIED

NZAP 2.4 Manual of Ceremonial and Drill
 Part 4 - Queen's Colour and Squadron Standard Ceremonial Drill
 Chapter 10 – Freedom of Entry to a City or Town

Version 6.00
 13 June 2023

| Table 4-10-1 Procedure for the Freedom of the City Parade (cont.) | | | |
|--|------------------|---|--|
| Serial | Commander | Command | Action |
| 8 | | | – At the conclusion of the Mayors address and before the Title Deed of Freedom is handed to the BCDR— |
| | PCDR | PARADE PARADE – SHUN | |
| 9 | | | – Before the BCDR addresses the assembly— |
| | PCDR | PARADE STAND AT – EASE | |
| 10 | | | – After the BCDR has addressed the assembly— |
| | PCDR | PARADE PARADE – SHUN UNCASE THE QUEEN'S COLOUR AND No. ___ SQUADRON STANDARD | |
| 11 | PCDR | MARCH ON No. ___ SQUADRON STANDARD PRESENT – ARMS | – The band plays Point of War. |
| 12 | SqnSB | STANDARD PARTY BY THE CENTRE QUICK – MARCH | – The SqnSP marches across the parade to its position in front of No.1 Squadron. |
| 13 | PCDR | PARADE SHOULDER – ARMS STAND AT EASE | <ul style="list-style-type: none"> – The scroll bearer and escort— – march to the front of the dais; – receive the Scroll from the BCDR; – turn about: – march and left wheel to the right flank of the parade; then – turn about. <p>Note: The scroll is to be carried in both hands, in front of the body and is not to be attached to the bearer by means of a cord.</p> |
| Parading the scroll | | | |
| 14 | PCDR | SCROLL BEARER PARADE THE SCROLL PARADE PARADE – SHUN | <ul style="list-style-type: none"> – The Scroll party, under the orders of the Scroll bearer— – marches in slow time along the front of the parade, paying compliments as it passes the QC, to the outer flank; – halts; – about turns; and – marches in quick time to a position in front of the last flight of the escort squadron. <p>Note: The most convenient time to stage the aircraft fly past is while the Scroll is being marched across the front of the parade in slow time.</p> |

UNCLASSIFIED

NZAP 2.4 Manual of Ceremonial and Drill
 Part 4 - Queen's Colour and Squadron Standard Ceremonial Drill
 Chapter 10 – Freedom of Entry to a City or Town

Version 6.00
 13 June 2023

| Table 4-10-1 Procedure for the Freedom of the City Parade (cont.) | | | |
|--|------------------|--|---|
| Serial | Commander | Command | Action |
| 15 | PCDR | PARADE GENERAL SALUTE PRESENT – ARMS | – The band plays the general salute and both the QC and the SqnS are let fly. |
| 16 | PCDR | SHOULDER – ARMS OFFICERS TAKE POST LEFT – TURN QUICK – MARCH OFFICERS INWARDS – TURN PARADE IN CLOSE ORDER RIGHT – DRESS EYES – FRONT | |
| March past | | | |
| 17 | PCDR | PARADE WILL MARCH PAST IN COLUMN OF ROUTE ESCORT SQUADRON LEADING MOVE TO THE RIGHT IN COLUMN OF ROUTE RIGHT – TURN | <ul style="list-style-type: none"> – The QCP takes up position between Nos.1 and 2 flights of the escort squadron. – The Scroll party takes up its position at the side of the dais. – The SqnSP takes up position between Nos.1 and 2 flights of No.1 Squadron. – When the parade has marched off, the Scroll is taken to the officers mess. |
| 18 | Escort SCDRs | ESCORT SQUADRON BY THE LEFT QUICK – MARCH | <ul style="list-style-type: none"> – The band starts playing and the parade moves off by squadrons. – Compliments are to be paid by flights. – The QCP and the SqnSP pay compliments on the orders of the bearers. – After marching through the city streets, the parade the area of dismissal. |

4.10.7 Dismissal

Dependent upon the area available for dismissal the PCDR may delegate the responsibility of marching off the QC to the escort squadron commander (ESCDR) and the SqnS to No.1 Squadron commander. Other squadrons may be dismissed independently by their PCDRs. After the QC has been marched off, the parade is brought to order, handed over to the PWO for dismissal.

4.10.8 Form of resolution

The following is a suggested form of resolution to be passed by the council of the municipality granting the Freedom of the city—

*That in appreciation of the honourable traditions of,
and in recognition of its long and intimate association with the Borough of
....., the Council confer upon the
..... the rights, privilege and honour of marching through the
streets of on all ceremonial occasions with bayonets
fixed, drums beating and Colours flying; that the Corporate Seal be affixed to the
necessary Deed of Grant and that the name of the
be inscribed on a panel in the Town Hall.*

| | | |
|---|--|--|
| | <div data-bbox="692 340 895 387" data-label="Text"><p>[City Crest]</p></div> | |
| <div data-bbox="638 528 948 562" data-label="Section-Header"><p><u>CITY OF NEW ZEALAND</u></p></div> | | |
| <div data-bbox="201 611 1383 649" data-label="Text"><p>To the Commanding Officer and personnel of RNZAF Base</p></div> | | |
| <div data-bbox="201 696 360 730" data-label="Section-Header"><p>GREETINGS</p></div> | | |
| <div data-bbox="201 781 542 815" data-label="Text"><p>The Council RESOLVED.....</p></div> | | |
| <div data-bbox="201 866 1383 1016" data-label="Text"><p>THAT WHEREAS HIS MAJESTY THE KING maintains a base of the Royal New Zealand Air Force at AND WHEREAS we the Mayor, Councillors and Citizens of the City of are of the opinion that it is desirable to confer certain privileges on the Commanding Officer and personnel of that Base.</p></div> | | |
| <div data-bbox="201 1068 1383 1254" data-label="Text"><p>It be And is Hereby RESOLVED that the City Council of does confer upon the Royal New Zealand Air Force Base at the privilege, honour and distinction of marching through the streets of the city on all ceremonial occasions with bayonets fixed, colours flying, drums beating and bands playing.</p></div> | | |
| <div data-bbox="201 1301 742 1337" data-label="Text"><p>IN WITNESS WHEREAS the Common Seal</p></div> | | |
| <div data-bbox="201 1364 632 1402" data-label="Text"><p>of the Corporation of the Mayor</p></div> | | |
| <div data-bbox="201 1426 699 1462" data-label="Text"><p>Councillors and Citizens of the City of</p></div> | | |
| <div data-bbox="201 1512 987 1545" data-label="Text"><p>..... was here unto affixed this SEAL</p></div> | | |
| <div data-bbox="201 1594 1193 1630" data-label="Text"><p>On theday of in the year</p></div> | | |
| <div data-bbox="201 1680 448 1715" data-label="Text"><p>In the presence of</p></div> | | |
| <div data-bbox="201 1765 671 1798" data-label="Text"><p>.....MAYOR</p></div> | | |
| <div data-bbox="201 1848 746 1883" data-label="Text"><p>.....TOWN CLERK</p></div> | | |

Figure 4-10-1 Suggested Format of Resolution Deed Granting Freedom of a City

Chapter 11 – Beating Retreat

4.11.1 Introduction

Paragraphs [4.11.2](#) and [4.11.3](#) provide a brief historical background, the elements that can be incorporated and a guide for the ceremony of Beating Retreat. The correct terminology is either 'beat retreat' or 'beating retreat', not 'beat the retreat', 'beating the retreat' or beating of retreat.

4.11.2 Historical background

- a. The ceremony of beating retreat is an old custom dating back to the 16th century when it was known as watch setting and was initiated at sunset by the firing of an evening gun. The ceremony consisted of prolonged drum-beating at sunset to warn the night guard to mount and give notice to soldiers beyond the confines of either the camp or the town walls that the gates were about to close and that they should return.
- b. This drill also signalled to civilians working in the fields that it was time to come back to the safety of the garrison.
- c. The custom has its origins too in the days when fighting ceased at sunset; the drumbeats signalled that the fighting was over.
- d. Over the centuries, this custom lost its significance until it was revived in 1890 by Sir John Moore, in a ceremony whereby his troops paid their respect to the fallen. Since this revival, the ceremony of beating retreat has become a military display involving bands and troops, and a traditional method of commemorating the fallen in all armed forces of the British Commonwealth.

4.11.3 Components of a beating retreat

- a. There is no set procedure for a beating retreat ceremony. The structure of the ceremony will depend on many factors, such as—
 - (1) area available; and
 - (2) restrictions on time available for appropriate rehearsals.
- b. The two essential parts of a beating retreat are—
 - (1) drum beatings; and
 - (2) sounding of the retreat call.
- c. Drum beating
 - (1) Once the band have marched on and are in position, the band master gives the command—

SOUND THE DRUMMERS CALL

UNCLASSIFIED

NZAP 2.4 Manual of Ceremonial and Drill

Version 6.00

Part 4 - Queen's Colour and Squadron Standard Ceremonial Drill

13 June 2023

Chapter 11 – Beating Retreat

- (a) If the drummers are not in the front rank of the band, they and the band master move to the front of the band.
 - (b) From there, under the command of the band master, the bass drummer gives a heavy beat on the bass drum.
 - (c) This is immediately followed by a drum roll by the side drums, which diminuendos to a stop under the command of the band master.
 - (d) This pairing is repeated three times and symbolises cannon fire and its reverberation.
 - (e) If present, cymbals can be included with the bass drum beat.
 - (f) The drummers then perform drum beatings to celebrate that the day has been successful.
 - (g) After the drum beatings, four drummers march to the four corners of the parade ground and then, with the other drummers, return to their position in the band.
 - (h) The marching to the four corners of the parade ground symbolises the posting of guards on the four corners of the fortress and then marching back through the town, beating retreat.
- d. Sounding of the retreat call
- (1) The guard commander gives the command—
SOUND THE RETREAT CALL
– The band plays the introduction to sunset.
 - (2) At the end of the introduction to sunset, the guard commander gives the command—
GUARD
GUARD – PRESENT ARMS
– The band continues with the retreat call superimposed over the hymn tune sunset.
– The RNZAF Ensign is lowered at this time.
– Service personnel come to attention.
– Officers salute.
 - (3) At the conclusion of the band playing sunset, the guard commander gives the command—
GUARD
GUARD – SHOULDER ARMS
– The flag orderlies fold the RNZAF Ensign.

- e. The beating retreat ceremony can also include the following—
 - (1) Māori cultural elements.
 - (2) Firing of three volleys.
 - (3) Playing of the evening hymn tune St Clements.
 - (4) Lone bagpipers lament.
- f. Māori cultural elements. Warriors move on to the parade area, perform a short karakia, and then post four warriors in the four corners of the parade area to act as sentries for the duration of the ceremony. After the ceremony and once the guard and band have marched off the warriors withdraw.
- g. Firing of three volleys. The tradition of firing three volleys in a beating retreat ceremony stems from the soldiers in the main body of troops firing three volleys of muskets. This was for the troops who were far spread and may not hear the drums beating retreat. It signalled for them to return to camp. It was said that the volleys also put to flight any unquiet spirits of departed soldiers. It has become traditional for a hymn to be played, between the volleys in honour of those who had fallen during the day. The hymn tune commonly used is Abide with Me. A separate firing party is recommended as the firing of volleys by the guard may be too close to the audience for safety reasons.
- h. Evening hymn tune St Clements. It is traditional for the band to play two verses of the evening hymn tune St Clements, also known as The Day Thou Gravest, Lord, is Ended.
- i. Lone bagpipers lament. The lone bagpiper is a Scottish tradition where the piper takes the place of a bugler to signal the day's end to troops, and bids farewell to the dead at funerals and memorial services. If it is included in the beating retreat ceremony, it should be performed after the retreat call has been played.

4.11.4 Organisation

- a. There is no strength stipulated for the beating retreat ceremony, however, it is usually made up as follows.
- b. **Guard.** The strength and composition of the guard may vary, however, a suggested composition is as follows—
 - (1) Guard Commander: one junior officer.
 - (2) Left and right guides: two senior non-commissioned officers (SNCOs).
 - (3) Guard members: 6 or 10 junior ranks.
- c. **Band.** The size of the band will depend on many factors but should be large enough to perform the ceremony's musical requirements to a satisfactory standard. A minimum of four drummers is required; this can include the base drummer and cymbal player. If the situation dictates, it would be possible to perform an abridged version of the beating retreat ceremony with just four drummers and a bugler.

- d. **Firing party.** If separate from the guard, the strength and composition of the firing party should be made up of a minimum of eight personnel under the command of a weapons qualified non-commissioned officer (NCO).
- e. **Warrior party.** The strength of the warrior party should be a minimum of four personnel.
- f. **Flag orderlies.** Two Flag orderlies are required to lower and fold the RNZAF Ensign.
- g. **Narrator.** A narrator is required for public ceremonies. A template for the narration to be delivered is shown in Figure [4-11-1](#).

4.11.5 Occasions to perform

Beating retreat is a solemn ceremony, which is usually performed in the late afternoon or early evening. Other activities or entertainments like band marching displays and the performance of Tchaikovsky's 1812 Overture can be performed before the ceremony but should be separate from the ceremony. It is customary within the RNZAF to perform a beating retreat ceremony in conjunction with RNZAF anniversary events but the ceremony can be performed at other appropriate occasions.

4.11.6 General format

The format and content of the beating retreat ceremony can vary. The following is a suggested format—

- (1) Posting of Māori warriors – optional.
- (2) Band and guard march on.
- (3) Beating retreat by the band drummers.
- (4) The guard advancing through the band.
- (5) The firing of three volleys – optional.
- (6) Playing of the evening hymn - optional.
- (7) Playing of 'retreat' and the lowering of the RNZAF Ensign.
- (8) Lone bagpiper lament- optional.
- (9) Band and guard march off.
- (10) Māori warriors withdraw - optional.

4.11.7 Beating retreat format

- a. **Preparatory.** Band and retreat party take up position at predetermined form up point.
- b. **Band and drums—**
 - (1) Band and drum corps—
 - (a) assume the ready position;

UNCLASSIFIED

NZAP 2.4 Manual of Ceremonial and Drill
Part 4 - Queen's Colour and Squadron Standard Ceremonial Drill
Chapter 11 – Beating Retreat

Version 6.00
13 June 2023

- (b) advance in quick time to a point immediately in front of dais;
 - (c) retreat counter march; and
 - (d) retire to rear of parade ground again.
- (2) When approaching original position they—
- (a) break into slow time;
 - (b) retreat counter march in front of retreat party; and
 - (c) halt when the rear rank has completed the movement and has advanced approximately 10 paces clear of the retreat party.
- (3) Cease playing at end of strain and steady.
- c. **Drum corps—**
- (1) sound the first call;
 - (2) sound second call;
 - (3) bass drum sounds fortissimo note;
 - (4) side drums follow with drum roll crescendo and diminuendo (Steps 3. and 4. are repeated three times);
 - (5) base drum then plays two beats in quick time as signal for drum corps advances in quick time; and
 - (6) drum corps—
 - (a) starts playing the retreat pattern;
 - (b) advances towards the dais;
 - (c) outward wheels (halt left, half right) to the flanks;
 - (d) marches to sides of parade area (or suitable distance);
 - (e) turns about and inwards;
 - (f) marches back to the centre;
 - (g) inward wheels to face band;
 - (h) marches through the ranks of the band to a position behind the band; and
 - (i) counter marches and advances towards their original position in front.
- d. **Band and retreat party—**
- (1) As the drum corps approaches their position the band master brings the band to the ready position.

UNCLASSIFIED

NZAP 2.4 Manual of Ceremonial and Drill

Version 6.00

Part 4 - Queen's Colour and Squadron Standard Ceremonial Drill

13 June 2023

Chapter 11 – Beating Retreat

- (2) As the drum corps emerges from the front of the band, the band commences playing at the same time stepping off.
 - (3) The retreat party, at the shoulder, steps off with the band and all advance towards the dais.
 - (4) At a point 20 m in front of the dais the drum corps, band and retreat party halt.
- e. **Trumpeter.** The trumpeter turns and marches smartly to take up a position on the right flank of the retreat party.
- f. **Band.** The band plays one verse of the hymn tune St Clements.
- g. **Band and retreat party—**
- (1) After a short pause, the band starts playing the first verse of hymn tune Abide with Me.
 - (2) At the same time, the retreat party and trumpeter step off in slow time on the first beat and slow march through the band for 31 paces, halting on the last beat of the first verse.
 - (3) The trumpeter comes to the ready on the 1st and 3rd beats.
 - (4) The retreat party carries out the present arms, on the 5th and 7th beats of the second verse.
- h. **Trumpeter.**
- (1) The trumpeter is to sounds the retreat starting on the 7th beat of the second verse as the RNZAF Ensign is lowered.
- Note:** Personnel come to attention and officers salute. On the occasion of the retreat being performed in conjunction with the Queens Colour handing over ceremony it is the Sovereign's personal flag for New Zealand that is lowered.
- (2) On the command of the PCDR, the retreat party and trumpeter shoulder arms.
 - (3) The band and trumpeter come to the steady position.
 - (4) The trumpeter about turns and marches back to position in the band.
- i. **Band and retreat party.**
- (1) Band comes to the 'ready'.
 - (2) On the band masters command, the entire party marches off the parade ground.

Kia ora koutou katoa, ladies and gentlemen. The ceremony you are about to witness is the ancient ceremony of beating retreat. The ceremony of beating retreat originated in the 16th century. The earliest known facts about retreat come from the year 1557 and a publication entitled Roles of Drummers and Fifes. It stated that the beating retreat on the battlefield conveyed the order to retire to the rear. From this early beginning, the call developed into a ceremony that signified the end of a soldier's working day. The modern ceremony represented here tonight dates to 1722 when, a half hour before sunset, at which time the fortress gates would be shut, drummers would go to the ramparts and beat retreat as a warning to guards.

[Guard now marches on.]

The guard is now preparing for the inspection, which will be carried out by—

.....

The guard this evening is drawn from (units).

The guard commander is—

[Inspection begins]

The inspection is symbolic of a custom where the guard commander would look into the eyes of each serviceperson to see if they are fit and capable of carrying out their duties. If the day's fighting had fared badly, the serviceperson may be exhausted or even wounded. If the fighting had been successful they may have over indulged in rum issue and therefore unfit for duty. You are assured that no person on the guard tonight is wounded or suffering from over-indulgence.

The ceremony of lowering the RNZAF Ensign and/or the national flag will begin with a fanfare and the hymn St Clements, followed by drummers beating retreat. The drummers will perform the victory beatings, which are believed to have developed through opposing battalion drummers attempting to outdo each other and thereby convey a message that no harm had been done during the day's hostilities. This will be followed by the hymn Sunset with the retreat call superimposed.

It is customary for all to stand, for all Service personnel to stand to attention and for all officers to salute throughout the lowering of the RNZAF Ensign and/or national flag.

[Band starts to play.]

The departure of the guard closes tonight's ceremony.

Thank you and good evening.

Figure 4-11-1 Suggested Introduction for Public Beating Retreat Ceremony

Chapter 12 – RNZAF Commemorative Service, Wellington Cathedral of St Paul

4.12.1 Historical significance

- a. Every year as close to the 1st of April as is reasonably practicable, a service of remembrance and thanksgiving is conducted. An assemblage of serving personnel, past members, dignitaries and invited guests gather to commemorate the founding of the Royal New Zealand Air Force (RNZAF), remember those who served in it in peace and war, particularly those personnel who lost their lives in conflicts.
- b. This commemorative service is also an occasion to remember those New Zealanders who fought and died while serving with other Air Forces of the Commonwealth.
- c. Additionally it is an occasion to acknowledge the service and dedication of Service personnel of today's RNZAF.

4.12.2 Memorial

To the left of the chancel, opposite the Bishop's throne, is a stained glass window dedicated to the memory of those who lost their lives on active service.

4.12.3 Laid up emblems

- a. Overhead at the left side of St Paul's Cathedral, Wellington, among the Queen's Colours (QCs) and Standards of other New Zealand Forces, hang—
 - (1) the original QC of the Royal New Zealand Air Force, presented in 1953; and
 - (2) the Squadron Standard (Sqns) of No. 75 Squadron bearing its battle honours from the Second World War, 1939-1945.
- b. These emblems are the very essence of RNZAF life. They symbolise loyalty, unity and courage, and also the fortitude displayed by members of the RNZAF in times of crisis.

4.12.4 Queen's Colour and RNZAF Squadron Standards

The QC and RNZAF Sqns are ceremonially marched into St Paul's Cathedral, Wellington by Queen's Colour party (QCP)/Squadron Standard parties (SqnsPs) on the occasion of the anniversary celebration each year. The QC is laid on the lower altar during the commemoration service. Sqns are mounted in stands either side of the QC.

4.12.5 Uncasing the Queen's Colour and Squadron Standards

- a. The QCP/SqnsPs uncase the QC/Sqns at a predetermined area 15 minutes before the service is due to start. (Refer to paragraph [4.3.2](#) Uncasing the Queen's Colour/Squadron Standard).

UNCLASSIFIED

NZAP 2.4 Manual of Ceremonial and Drill

Version 6.00

Part 4 - Queen's Colour and Squadron Standard Ceremonial Drill

13 June 2023

Chapter 12 – RNZAF Commemorative Service, Wellington Cathedral of St Paul

4.12.6 Handing over of weapons

- a. It is not deemed necessary to take weapons into the Cathedral as it a consecrated place and historically once the QC/SqnSs have entered the 'House of God' they considered to be protected. So, before the QC/SqnS is marched into the Cathedral, weapons are handed to weapons orderlies and retained outside the Cathedral for the duration of the ceremony.
- b. This handing over of weapons usually takes place at the front entrance of the Cathedral, but it can also be performed inside, should the weather dictate. The series of commands and actions can be adjusted to suit, dependent on where the uncasing is to take place.
- c. Table [4-12-1](#) lists the words of command given by the Queen's Colour bearer (QCB)/ Squadron Standard bearer (SqnSB), or by the weapons orderly commander (WOC) if more than one QC/SqnS are being paraded, for the receiving of arms by the weapons orderlies from the QCP/SqnSPs before the commemoration service.

Table 4-12-1 Weapons Orderlies Receiving Weapons Before Entry into the Cathedral

| Serial | Commander | Command | Action |
|--------|-----------|--|---|
| 1 | WOC | ORDERLIES BY THE CENTRE QUICK MARCH | <ul style="list-style-type: none"> – Orderlies step off with a full 75 cm pace. – Orderlies dress by the left. |
| 2 | WOC | ORDERLIES HALT | <ul style="list-style-type: none"> – Given as the right foot strikes the ground when the lead orderly is one pace from the position at which to halt. |
| 3 | WOC | ORDERLIES INWARDS TURN | <ul style="list-style-type: none"> – Orderlies left/right turn to face their opposite orderly. – Orderlies pick up the dressing in double quick time. |
| 4 | WOC | ORDERLIES SALUTE | <ul style="list-style-type: none"> – Given when the lead QCP/SqnSP is seven paces from the first weapon orderly – Orderlies salute. – Remain at the salute. |
| 5 | WOC | ORDERLIES STEADY | <ul style="list-style-type: none"> – Given after QC/SqnS W/O has given the command for the QCP/SqnSPs to halt. – Orderlies cut the right arm away to the side of the body in double quick time. |
| 6 | QCB | TO THE COLOUR/STANDARD OUTWARD TURN | <ul style="list-style-type: none"> – QCP/SqnSP outward turn to face their opposite weapons orderly. |

UNCLASSIFIED

NZAP 2.4 Manual of Ceremonial and Drill

Version 6.00

Part 4 - Queen's Colour and Squadron Standard Ceremonial Drill

13 June 2023

Chapter 12 – RNZAF Commemorative Service, Wellington Cathedral of St Paul

| Table 4-12-1 Weapons Orderlies Receiving Weapons Before Entry into the Cathedral (cont.) | | | |
|---|------------------|---|--|
| Serial | Commander | Command | Action |
| 7 | QCB | TO THE COLOUR/STANDARD EXCHANGE ARMS | <ul style="list-style-type: none"> – Escort forces the weapon out. – At the same time the orderly places their hands on weapon – The weapon is rotated by the escort so that the orderly grips the weapon. – The escort extends their fingers resting the palm on the weapon that the orderly now has a grip of. |
| 8 | WOC | SHOULDERARMS | <ul style="list-style-type: none"> – Orderlies shoulder arms. – Orderlies cut their arms away to the side of the body in double quick time. |
| 9 | WOC | INWARDS TURN | <ul style="list-style-type: none"> – Inward turn to face the direction if travel. |
| 10 | QCB | COLOUR/STANDARD PARTY SLOW MARCH | <ul style="list-style-type: none"> – QC/SqnS party marches off. |
| 11 | WOC | ORDERLIES OUTWARD TURN | <ul style="list-style-type: none"> – Orderlies left/right turn to face the direction of travel. – Weapon on the shoulder. |
| 12 | WOC | ORDERLIES QUICK MARCH | <ul style="list-style-type: none"> – Orderlies step off with a full 75 cm pace. – Dressing by the left. |
| 13 | WOC | ORDERLIES HALT | <ul style="list-style-type: none"> – Given when the party arrives at the place from where they are to be dismissed. – Orderlies halt. |
| 14 | WOC | ORDERLIES DISMISS. | <ul style="list-style-type: none"> – Orderlies turn right. – Pause. – Carry out individual service drill movements. |

4.12.7 QCP/SqnSP assembly

- a. The procedure for the QCP/SqnSP assembly for the anniversary ceremony at St Paul's Cathedral for both outside and wet weather, indoor assemblies is as follows—

Each QCB/SqnSB gives the following commands to their respective parties—

COLOUR/STANDARD PARTY**LEFT FIXED PIVOT WHEEL****QUICK MARCH****COLOUR/STANDARD/STANDARD PARTY – HALT**

- The QCP/SqnSP adjusts its dressing as the kaikaranga is being delivered in preparation for parading the QC/SqnS.

UNCLASSIFIED

NZAP 2.4 Manual of Ceremonial and Drill

Version 6.00

Part 4 - Queen's Colour and Squadron Standard Ceremonial Drill

13 June 2023

Chapter 12 – RNZAF Commemorative Service, Wellington Cathedral of St Paul

- b. In fine weather the QCP/SqnSPs are in position outside of the Cathedral and the weapons ceremony has been completed, the QC party positions itself at the front entrance of the Cathedral.
- c. For inclement weather the QCP/SqnSPs assemble in the predetermined location within the Cathedral.

4.12.8 VIP procession

- a. At a predetermined time, the procession of clergy and the Chief of Air Force (CAF) enters the Cathedral.
- b. Once the clergy and CAF are in place, the QCP slow marches into position at the front of the cathedral (from either their inside or outside assembly point).
- c. The SqnSPs follow the QCP, maintaining a predetermined spacing between each party.
- d. On entry and exit the QC/SqnSPs are carried at the shoulder to avoid contact with the doorway arch and underside of the upstairs gallery.
- e. The QCP/SqnSPs wait to be invited to parade the QC/SqnSP.

4.12.9 Kaikaranga

The kaikaranga is delivered by a member of the Māori Cultural Group. (MCG).

4.12.10 Procession of the QC and SqnSPs

- a. Once the kaikaranga has been delivered the QCB/SqnSP process in as shown in Table [4-12-2](#).

Table 4-12-2 Procession of Queen's Colour/Squadron Standard(s) inside the Cathedral

| Serial | Commander | Command | Action |
|--------|--|--|--|
| 1 | Each QCB/SqnSP | COLOUR/STANDARD PARTY BY THE CENTRE SLOW..... | – On the 3rd beat of the drum, the QCP/SqnSP slow marches down the aisle to a predetermined position near the lower altar. |
| 2 | – As the QCP/SqnSP approaches the predetermined mark– QCB/SqnSP | COLOUR/STANDARD PARTY HALT | – The QCP/SqnSP halts. |
| 3 | QCB/SqnSP | COLOUR PARTY RIGHT FIXED PIVOT WHEEL QUICK MARCH COLOUR PARTY – HALT COLOUR PARTY TAKE – POST | – QCB/SqnSP adjusts dressing as required. |

UNCLASSIFIED

NZAP 2.4 Manual of Ceremonial and Drill

Version 6.00

Part 4 - Queen's Colour and Squadron Standard Ceremonial Drill

13 June 2023

Chapter 12 – RNZAF Commemorative Service, Wellington Cathedral of St Paul

| Table 4-12-2 Procession of Queen's Colour/Squadron Standard(s) inside the Cathedral(cont.) | | | |
|---|--|--|---|
| Serial | Commander | Command | Action |
| 4 | – When the Chaplain/Dean is in position at the altar— | | |
| | QCB | COLOUR PARTY BY THE CENTRE SLOW – MARCH | – The QCP slow marches to the predetermined mark. |
| 5 | QC W/O | HALT | – The QCB— – continues forward; – halts at the altar rail; – slight tilting of the Crown at the top of the pike to the left as they hand the QC/SqnStd to the Chaplain/Dean; – salutes; and – steps back into their position in the QCP. |
| 6 | If weapons are approved to be carried inside the Cathedral— | | |
| | QC W/O | ESCORTS PRESENT – ARMS | |
| 7 | Transfer and display of the QC— | | |
| | | | – The Chaplain/Dean— – turns and – moves to the altar, – places the QC in position with the Royal Cypher draped facing the congregation, the pike resting on the altar and the ferrule to the left. – The QCB remains at the salute while the QC is being placed. Note: There may be a requirement to have some assistance for the Chaplain/Dean. |
| Fanfare and New Zealand National Anthem | | | |
| 7 | – When the Chaplain/Dean steps back facing the altar, the band plays a fanfare of trumpets and drum roll. | | |
| | – The band plays the New Zealand National Anthem. | | |
| 8 | – When the New Zealand National Anthem is completed— | | |
| | QC W/O | ESCORTS SHOULDER – ARMS | – This completes the salute. |
| 9 | QCB | COLOUR PARTY RIGHT – TURN QUICK – MARCH | – The QCP under the command of the QCB, with the QCB leading, followed by escorts and the QC W/O at the rear— – march off to the side; – halt; and – dismiss. |
| 10 | – The SqnSs are processed in as for the QC (serials 4–9), except that at Serial 7 the SqnSs are displayed in stands on either side of the altar. | | |

UNCLASSIFIED

NZAP 2.4 Manual of Ceremonial and Drill

Version 6.00

Part 4 - Queen's Colour and Squadron Standard Ceremonial Drill

13 June 2023

Chapter 12 – RNZAF Commemorative Service, Wellington Cathedral of St Paul

Table 4-12-2 Procession of Queen's Colour/Squadron Standard(s) inside the Cathedral(cont.)

| Serial | Commander | Command | Action |
|--------|-----------|---------|--|
| 11 | | | <ul style="list-style-type: none"> - The QCP and SqnSP occupy seats near the exit door as members of the congregation. <p>Note: There may be a considerable period of waiting from this stage to the hymn.</p> |

4.12.11 Retrieval of the QC and SqnSs

- a. After the anniversary ceremony the QCP/SqnSPs reassemble in the side aisle ready to retrieve the QC/SqnSs ready to recess out of the cathedral.
- b. The procedure for the recession is shown in Table [4-12-3](#).

Table 4-12-3 Recession of the Queen's Clour/Squadron Standards

| Serial | Commander | Command | Action |
|---------------------------|-----------|---|--|
| 1 | | | <ul style="list-style-type: none"> - When the hymn starts the QCP form up ready to march back down the aisle. - During the second verse of the hymn, when the QCP has formed up in the side aisle— |
| Handover of the QC | | | |
| 2 | | | <ul style="list-style-type: none"> - The Chaplain/Dean passes the QC to the QCB. - The QCB— <ul style="list-style-type: none"> - shoulders the QC; - turns right; - marches in quick time wheeling right down the steps; and - halts, - At the same time, the QC W/O, from the position previously occupied by the QCB, times their move so that both members halt together when they arrive in the chancel. - If possible, the QCB brings the QC to the carry. |
| The commemoration | | | |
| 3 | | | <ul style="list-style-type: none"> - The Chaplain/Dean recites the commemoration. - After the commemoration, the congregation responds. - The Last Post is played. |
| Last Post | | | |
| 4 | | | <ul style="list-style-type: none"> - As the bugler begins to play the Last Post (if weapons are approved to be carried inside the Cathedral)— |
| | QCB | COLOUR PARTY PRESENT – ARMS | |
| 5 | | | <ul style="list-style-type: none"> - When the Last Post is finished— |
| | QCB | COLOUR PARTY SHOULDER – ARMS | Note: The QC is let to fly but remains at the carry, escorts present arms and W/O salutes. |
| Vesper hymn | | | |
| 6 | | | <ul style="list-style-type: none"> - The band plays the Vespers hymn, which is sung by the congregation. - QCP remain fast at the shoulder. - When the hymn is completed the Reveille follows. |

UNCLASSIFIED

NZAP 2.4 Manual of Ceremonial and Drill

Version 6.00

Part 4 - Queen's Colour and Squadron Standard Ceremonial Drill

13 June 2023

Chapter 12 – RNZAF Commemorative Service, Wellington Cathedral of St Paul

| Table 4-12-3 Recession of the Queen's Clour/Squadron Standards (cont.) | | | |
|---|---|---|--|
| Serial | Commander | Command | Action |
| Reveille | | | |
| 7 | – The bugler plays Reveille. | | |
| | QCB | COLOUR PARTY PRESENT – ARMS | |
| 8 | – When the bugler has finished— | | |
| | QCB | COLOUR PARTY SHOULDER – ARMS | |
| The blessing | | | |
| 9 | <ul style="list-style-type: none"> – The Chaplain/Dean delivers the blessing. – After 'Amen', the band plays the pathfinders march. – QCP marches off in quick time. | | |
| 10 | QCB | COLOUR PARTY BY THE CENTRE QUICK – MARCH | <ul style="list-style-type: none"> – The QCP marches— <ul style="list-style-type: none"> – through the chancel; – down the steps; and – halts in clear space. – The QCB lowers the QC to the shoulder as they pass under the entrance archway. – The QCP marches forward and vacates the area through the main entrance to the Cathedral. |
| 11 | – As the QCP is marching down the aisle towards the exit, the SqnSPs retrieve their respective SqnSs as for the QC in Serial 2. | | |

4.12.12 Casing the QC

When the QCP arrives in clear space in a suitable location, the QC is to be properly dismounted and the QC is to be cased.

Note: It would be prudent to note that the background noise of the band, pipe organ and choir, at varying intervals throughout the service, may tend to nullify commands. Therefore, during the service, it will be necessary to deliver commands in a loud clear voice in order to be heard. Practices conducted beforehand do not, of themselves, convey the right atmosphere.

4.12.13 Return of weapons

Table [4-12-4](#) lists the words of command given by the QCB, or orderly commander if more than one QC or SqnS is being paraded for returning arms to the QCP after the commemoration service.

UNCLASSIFIED

UNCLASSIFIED

NZAP 2.4 Manual of Ceremonial and Drill

Version 6.00

Part 4 - Queen's Colour and Squadron Standard Ceremonial Drill

13 June 2023

Chapter 12 – RNZAF Commemorative Service, Wellington Cathedral of St Paul

Table 4-12-4 Procedure for the Return of Weapons

| Serial | Commander | Command | Action |
|--------|-----------|--|---|
| 1 | WOC | ORDERLIES BY THE CENTRE QUICK MARCH | <ul style="list-style-type: none"> - Orderlies— - step off with a full 75 cm pace; and - dress by the left. |
| 2 | WOC | ORDERLIES HALT | <ul style="list-style-type: none"> - The command is given as the right foot strikes the ground when the lead orderly is one pace from the position to halt. |
| 3 | WOC | ORDERLIES INWARDS TURN. | <ul style="list-style-type: none"> - Orderlies— - left/right turn to face their opposite orderly; and - pick up their dressing in double quick time. |
| 4 | QCB | COLOUR PARTY HALT | <ul style="list-style-type: none"> - QC escort orderlies— - march in between the weapons orderlies; and - halt as commended. |
| 5 | WOC | TO THE COLOUR OUTWARD TURN | <ul style="list-style-type: none"> - QC escort orderlies outward turn to face their opposite weapons orderly. |
| 6 | WOC | TO THE COLOUR EXCHANGE ARMS | <ul style="list-style-type: none"> - Weapons orderlies forces the weapons out. - At the same time the escort places their hands weapon. - The weapon is rotated by the weapons orderly so that the escort grips the weapon. - The orderly extends their fingers resting the palm on the weapon that the escort now has a grip of. |
| 7 | QCB | SHOULDER ARMS | <ul style="list-style-type: none"> - Orderlies cut their arms away to the side of the body in double quick time. |
| 8 | QCB | INWARDS TURN | <ul style="list-style-type: none"> - Inward turn to face the direction if travel. |
| 9 | QCB | COLOUR PARTY QUICK MARCH | <ul style="list-style-type: none"> - QCP marches off. |
| 10 | WOC | ORDERLIES OUTWARD TURN | <ul style="list-style-type: none"> - Orderlies left/right turn to face the direction of travel. |
| 11 | WOC | ORDERLIES QUICK MARCH | <ul style="list-style-type: none"> - Orderlies step off with a full 75 cm pace, dressing by the left. |
| 12 | WOC | ORDERLIES HALT | |
| 13 | WOC | ORDERLIES FALL OUT | <ul style="list-style-type: none"> - Orderlies— - turn right; - pause; and - carry out individual service drill movements. |

UNCLASSIFIED

NZAP 2.4 Manual of Ceremonial and Drill
End Matter

Version 7(6)
18 January 2024

End Matter

Amendment Certificate

Amendment List: 7 dated 18 JAN 2024

Previous Amendments: ALs 1 to 5 are incorporated 6 13 JUN 2023

Page List and State: Only pages marked with '*' on right hand side of column are actioned.

Total number of pages in this publication is 441 consisting of the following:

| Page No | Ver No | Page No | Ver No | Page No | Ver No | Page No | Ver No |
|-------------------|--------|-------------------|--------|-------------------|--------|-------------------|--------|
| Cover | N/A | 1-17 | 6 | 1-51 | 6 | 1-91 | 6 |
| ii | 6 | 1-18 | 6 | 1-52 | 6 | 1-92 | 6 |
| iii | 6 | | | 1-53 | 6 | 1-93 | 6 |
| iv | 6 | Chapter 3 | | 1-54 | 6 | 1-94 | 6 |
| v | 6 | 1-19 | 6 | 1-55 | 6 | 1-95 | 6 |
| 1 | 6 | 1-20 | 6 | 1-56 | 6 | 1-96 | 6 |
| 2 | 6 | 1-21 | 6 | 1-57 | 6 | 1-97 | 6 |
| 3 | 6 | 1-22 | 6 | 1-58 | 6 | 1-98 | 6 |
| 4 | 6 | 1-23 | 7* | 1-59 | 6 | 1-99 | 6 |
| 5 | 6 | 1-24 | 7* | 1-60 | 6 | 1-100 | 6 |
| | | 1-25 | 6 | 1-61 | 6 | 1-101 | 6 |
| | | 1-26 | 6 | 1-62 | 6 | 1-102 | 6 |
| PART 1 | | 1-27 | 6 | 1-63 | 6 | 1-103 | 6 |
| 1-TOC-1 | 6 | 1-28 | 6 | 1-64 | 6 | 1-104 | 6 |
| 1-TOC-2 | 6 | 1-29 | 6 | 1-65 | 6 | 1-105 | 6 |
| 1-TOC-3 | 6 | 1-30 | 6 | 1-66 | 6 | 1-106 | 6 |
| 1-TOC-4 | 6 | 1-31 | 6 | 1-67 | 6 | 1-107 | 6 |
| 1-TOC-5 | 6 | 1-32 | 6 | 1-68 | 6 | 1-108 | 6 |
| 1-TOC-6 | 6 | 1-33 | 6 | 1-69 | 6 | 1-109 | 6 |
| 1-TOC-7 | 6 | | | 1-70 | 6 | 1-110 | 6 |
| 1-TOC-8 | 6 | Chapter 4 | | 1-71 | 6 | 1-111 | 6 |
| Chapter 1 | | 1-34 | 6 | 1-72 | 6 | 1-112 | 6 |
| 1-1 | 6 | 1-35 | 6 | 1-73 | 6 | 1-113 | 6 |
| 1-2 | 6 | 1-36 | 6 | 1-74 | 6 | 1-114 | 6 |
| 1-3 | 6 | 1-37 | 6 | 1-75 | 6 | 1-115 | 6 |
| 1-4 | 6 | 1-38 | 6 | 1-76 | 6 | | |
| 1-5 | 6 | 1-39 | 6 | 1-77 | 6 | Chapter 6 | |
| 1-6 | 6 | 1-40 | 6 | 1-78 | 6 | 1-116 | 6 |
| 1-7 | 6 | 1-41 | 6 | 1-79 | 6 | 1-117 | 6 |
| 1-8 | 6 | 1-42 | 6 | 1-80 | 6 | 1-118 | 6 |
| 1-9 | 6 | 1-43 | 6 | 1-81 | 6 | 1-119 | 6 |
| 1-10 | 6 | 1-44 | 6 | 1-82 | 6 | 1-120 | 6 |
| | | 1-45 | 6 | 1-83 | 6 | 1-121 | 6 |
| Chapter 2 | | | | 1-84 | 6 | 1-122 | 6 |
| 1-11 | 6 | Chapter 5 | | 1-85 | 6 | 1-123 | 6 |
| 1-12 | 6 | 1-46 | 6 | 1-86 | | 1-124 | 6 |
| 1-13 | 6 | 1-47 | 6 | 1-87 | 6 | 1-125 | 6 |
| 1-14 | 6 | 1-48 | 6 | 1-88 | 6 | 1-126 | 6 |
| 1-15 | 6 | 1-49 | 6 | 1-89 | 6 | 1-127 | 6 |
| 1-16 | 6 | 1-50 | 6 | 1-90 | 6 | 1-128 | 6 |

EM-1

UNCLASSIFIED

UNCLASSIFIED

| Page No | Ver No | Page No | Ver No | Page No | Ver No | Page No | Ver No |
|-------------------|--------|-------------------|--------|-------------------|--------|-------------------|--------|
| 1-129 | 6 | 2-31 | 6 | 3-13 | 6 | 3-56 | 6 |
| 1-130 | 6 | 2-32 | 6 | 3-14 | 6 | 3-57 | 6 |
| 1-131 | 6 | 2-33 | 6 | 3-15 | 6 | 3-58 | 6 |
| 1-132 | 6 | 2-34 | 6 | 3-16 | 6 | 3-59 | 6 |
| 1-133 | 6 | 2-35 | 6 | 3-17 | 6 | 3-60 | 6 |
| 1-134 | 6 | 2-36 | 6 | | | 3-61 | 6 |
| 1-135 | 6 | 2-37 | 6 | Chapter 4 | | 3-62 | 6 |
| 1-136 | 6 | | | 3-18 | 6 | 3-63 | 6 |
| 1-137 | 6 | Chapter 5 | | 3-19 | 6 | 3-64 | 6 |
| 1-138 | 6 | 2-38 | 6 | 3-20 | 6 | | |
| 1-139 | 6 | 2-39 | 6 | 3-21 | 6 | Chapter 10 | |
| 1-140 | 6 | 2-40 | 6 | 3-22 | 6 | 3-65 | 6 |
| | | 2-41 | 6 | 3-23 | 6 | 3-66 | 6 |
| | | 2-42 | 6 | | | 3-67 | 6 |
| PART 2 | | | | | | | |
| 2-TOC-1 | 6 | 2-43 | 6 | Chapter 5 | | | |
| 2-TOC-2 | 6 | 2-44 | 6 | 3-24 | 6 | Chapter 11 | |
| 2-TOC-3 | 6 | 2-45 | 6 | 3-25 | 6 | 3-68 | 6 |
| | | 2-46 | 6 | 3-26 | 6 | 3-69 | 6 |
| Chapter 1 | | 2-47 | 6 | 3-27 | 6 | 3-70 | 6 |
| 2-1 | 6 | 2-48 | 6 | 3-28 | 6 | 3-71 | 6 |
| 2-2 | 6 | 2-49 | 6 | 3-29 | 6 | 3-72 | 6 |
| 2-3 | 6 | 2-50 | 6 | 3-30 | 6 | 3-73 | 6 |
| 2-4 | 6 | 2-51 | 6 | 3-31 | 6 | 3-74 | 6 |
| 2-5 | 6 | 2-52 | 6 | 3-32 | 6 | 3-75 | 6 |
| 2-6 | 6 | 2-53 | 6 | 3-33 | 6 | 3-76 | 6 |
| 2-7 | 6 | | | 3-34 | 6 | 3-77 | 6 |
| 2-8 | 6 | Chapter 6 | | 3-35 | 6 | 3-78 | 6 |
| 2-9 | 6 | 2-54 | 6 | 3-36 | 6 | 3-79 | 6 |
| 2-10 | 6 | 2-55 | 6 | 3-37 | 7* | 3-80 | 6 |
| 2-11 | 6 | 2-56 | 6 | 3-38 | 7* | | |
| | | | | 3-39 | 6 | Chapter 12 | |
| Chapter 2 | | PART 3 | | 3-40 | 6 | 3-81 | 6 |
| | | 3-TOC-1 | 6 | 3-41 | 6 | 3-82 | 6 |
| 2-12 | 6 | 3-TOC-2 | 6 | 3-42 | 6 | 3-83 | 6 |
| 2-13 | 6 | 3-TOC-3 | 6 | | | 3-84 | 6 |
| 2-14 | 6 | 3-TOC-4 | 6 | Chapter 6 | | 3-85 | 6 |
| 2-15 | 6 | 3-TOC-5 | 6 | 3-43 | 6 | 3-86 | 6 |
| 2-16 | 6 | 3-TOC-6 | 6 | | | 3-87 | 6 |
| 2-17 | 6 | | | Chapter 7 | | 3-88 | 6 |
| | | Chapter 1 | | 3-44 | 6 | 3-89 | 6 |
| Chapter 3 | | 3-1 | 6 | 3-45 | 6 | 3-90 | 6 |
| 2-18 | 6 | 3-2 | 6 | 3-46 | 6 | | |
| 2-19 | 6 | 3-3 | 6 | 3-47 | 6 | PART 4 | |
| 2-20 | 6 | 3-4 | 6 | 3-48 | 6 | 4-TOC-1 | 6 |
| | | 3-5 | 6 | 3-49 | 6 | 4-TOC-2 | 6 |
| Chapter 4 | | 3-6 | 6 | 3-50 | 6 | 4-TOC-3 | 6 |
| 2-21 | 6 | | | 3-51 | 6 | 4-TOC-4 | 6 |
| 2-22 | 6 | Chapter 2 | | 3-52 | 6 | 4-TOC-5 | 6 |
| 2-23 | 6 | 3-7 | 6 | 3-53 | 6 | 4-TOC-6 | 6 |
| 2-24 | 6 | 3-8 | 6 | | | 4-TOC-7 | 6 |
| 2-25 | 6 | 3-9 | 6 | | | | |
| 2-26 | 6 | 3-10 | 6 | Chapter 8 | | Chapter 1 | |
| 2-27 | 6 | | | 3-54 | 6 | 4-1 | 6 |
| 2-28 | 6 | Chapter 3 | | | | 4-2 | 6 |
| 2-29 | 6 | 3-11 | 6 | Chapter 9 | | 4-3 | 6 |
| 2-30 | 6 | 3-12 | 6 | 3-55 | 6 | 4-4 | 6 |

UNCLASSIFIED

NZAP 2.4 Manual of Ceremonial and Drill
End Matter

Version 7(6)
18 January 2024

| Page No | Ver No | Page No | Ver No | Page No | VerNo | Page No | Ver No |
|-------------------|--------|-------------------|--------|-------------------|-------|-------------------|--------|
| Chapter 2 | | 4-36 | 6 | 4-66 | 6 | Chapter 10 | |
| 4-5 | 6 | 4-37 | 6 | 4-67 | 6 | 4-98 | 6 |
| 4-6 | 6 | 4-38 | 6 | 4-68 | 6 | 4-99 | 6 |
| 4-7 | 6 | | | 4-69 | 6 | 4-100 | 6 |
| 4-8 | 6 | Chapter 5 | | 4-70 | 6 | 4-101 | 6 |
| | | 4-39 | 6 | 4-71 | 6 | 4-102 | 6 |
| Chapter 3 | | 4-40 | 6 | 4-72 | 6 | 4-103 | 6 |
| 4-9 | 6 | 4-41 | 6 | 4-73 | 6 | 4-104 | 6 |
| 4-10 | 6 | 4-42 | 6 | 4-74 | 6 | | |
| 4-11 | 6 | 4-43 | 6 | 4-75 | 6 | Chapter 11 | |
| 4-12 | 6 | 4-44 | 6 | 4-76 | 6 | 4-105 | 6 |
| 4-13 | 6 | 4-45 | 6 | 4-77 | 6 | 4-106 | 6 |
| 4-14 | 6 | 4-46 | 6 | 4-78 | 6 | 4-107 | 6 |
| 4-15 | 6 | 4-47 | 6 | 4-79 | 6 | 4-108 | 6 |
| 4-16 | 6 | 4-48 | 6 | 4-80 | 6 | 4-109 | 6 |
| 4-17 | 6 | 4-49 | 6 | 4-81 | 6 | 4-110 | 6 |
| 4-18 | 6 | 4-50 | 6 | | | 4-111 | 6 |
| 4-19 | 6 | 4-51 | 6 | Chapter 8 | | | |
| 4-20 | 6 | 4-52 | 6 | 4-82 | 6 | Chapter 12 | |
| 4-21 | 6 | 4-53 | 6 | 4-83 | 6 | 4-112 | 6 |
| 4-22 | 6 | 4-54 | 6 | 4-84 | 6 | 4-113 | 6 |
| | | 4-55 | 6 | 4-85 | 6 | 4-114 | 6 |
| Chapter 4 | | 4-56 | 6 | 4-86 | 6 | 4-115 | 6 |
| 4-23 | 6 | 4-57 | 6 | | | 4-116 | 6 |
| 4-24 | 6 | 4-58 | 6 | Chapter 9 | | 4-117 | 6 |
| 4-25 | 6 | 4-59 | 6 | 4-87 | 6 | 4-118 | 6 |
| 4-26 | 6 | 4-60 | 6 | 4-88 | 6 | 4-119 | 6 |
| 4-27 | 6 | 4-61 | 6 | 4-89 | 6 | | |
| 4-28 | 6 | | | 4-90 | 6 | End Matter | |
| 4-29 | 6 | Chapter 6 | | 4-91 | 6 | EM-1 | 7* |
| 4-30 | 6 | 4-62 | 6 | 4-92 | 6 | EM-2 | 7* |
| 4-31 | 6 | 4-63 | 6 | 4-93 | 6 | EM-3 | 7* |
| 4-32 | 6 | 4-64 | 6 | 4-94 | 6 | | |
| 4-33 | 6 | | | 4-95 | 6 | END | |
| 4-34 | 6 | Chapter 7 | | 4-96 | 6 | | |
| 4-35 | 6 | 4-65 | 6 | 4-97 | 6 | | |

| | |
|--------------------------|-------|
| INCORPORATED: Signature: | Date: |
|--------------------------|-------|